



# **PARTS CATALOGUE**

**EK9.9DMH'09** (6B76)

**EK15DMH'09** (6B86)

**EK9.9JMH'09** (6B96)

**EK15PMH'09** (6C06)

EK9.9DMH/EK15DMH  
EK9.9JMH/EK15PMH  
PARTS CATALOGUE  
©2008 by Yamaha Motor Co., Ltd.  
1st edition, August 2008  
All rights reserved.  
Any reprinting or unauthorized use  
without the written permission of  
Yamaha Motor Co., Ltd.  
is expressly prohibited.  
Printed in Japan.

# FOREWORD

This Parts Catalogue is related to the parts for the model(s) on the cover page. When you are ordering replacement parts, please refer to this Parts Catalogue and quote both part numbers and part names correctly.

1. Modifications or additions which have been made after the issue of the Parts Catalogue will be announced in the Parts News.  
It is advisable that you make the necessary corrections to the Parts Catalogue according to the Parts News.

2. Abbreviations

The following abbreviations are used in this Parts Catalogue.

“UR” Use specified parts number.

“UN” Use as many as needed.

“AP” Alternate Parts

“LM” Locally Made (Parts need to be ordered locally)

“F#” Frame No. (Applicable machine No.)

“O/S” Over Size

3. The number of components for assembly

- Parts, which are to be supplied in an assembly, are listed with a dot (.) in front of the part name as shown below.
- The numeral appearing to the right of each component part indicates the quantity of parts for each assembly unit.

PART NO.	DESCRIPTION	Q'TY	REMARKS
2F5-83310-60	FRONT FLASHER LIGHT ASSY	2	
115-83311-60	.BULB (6V-18W)	1	

4. Applicable colours of graphics are represented in the “REMARKS” as shown below.

PART NO.	DESCRIPTION	Q'TY	REMARKS
2N4-24110-00-X5	FUEL TANK COMP.	2	MXR
3J1-24240-10	.GRAPHIC, FUEL TANK	1	FOR MXR

5. Note that the illustrations for reference in finding parts numbers are not to be used for assembling. When assembling, please use the applicable service manual.

6. The asterisk (\*) before a reference number indicates modified items after the first edition.

7. Applicable Serial No.

Engine Serial No.

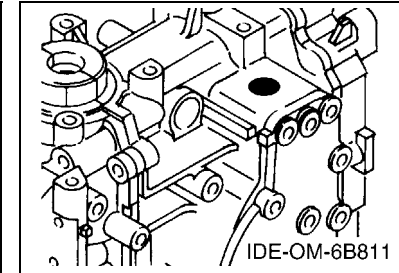
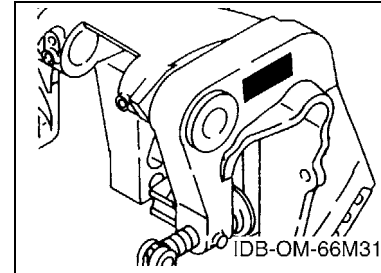

8. Applicable Engine Starting Serial No.

Model	Serial No.	Model	Serial No.
EK9.9D	6B7K-1004311	EK15D	6B8K-1003234
EK9.9J	6B9K-1002918	EK15P	6C0K-1004685

9. Applicable Colour Code

Abbreviation	Colour Name	Colour Code
DBNM2	DARK BLUISH GRAY METALLIC 2	004D

10. Quantity Column Information

Column No.	Name Of Q'ty Column	Applicable Model
1	6B76	EK9.9DMH
2	6B96	EK9.9JMH
3	6B86	EK15DMH
4	6C06	EK15PMH

# CONTENTS

TOP COWLING .....	1
CYLINDER & CRANKCASE .....	2
CRANKSHAFT & PISTON .....	4
INTAKE .....	6
CARBURETOR .....	7
FUEL 1 .....	9
FUEL 2 .....	11
STARTER .....	12
GENERATOR .....	14
ELECTRICAL .....	15
BOTTOM COWLING .....	16
STEERING .....	17
CONTROL .....	18
BRACKET 1 .....	20
BRACKET 2 .....	23
UPPER CASING .....	25
LOWER CASING & DRIVE 1 .....	26
LOWER CASING & DRIVE 2 .....	29
FUEL TANK .....	31
REPAIR KIT 1 .....	32
REPAIR KIT 2 .....	34

## INDEX

NUMERICAL INDEX .....	35
-----------------------	----

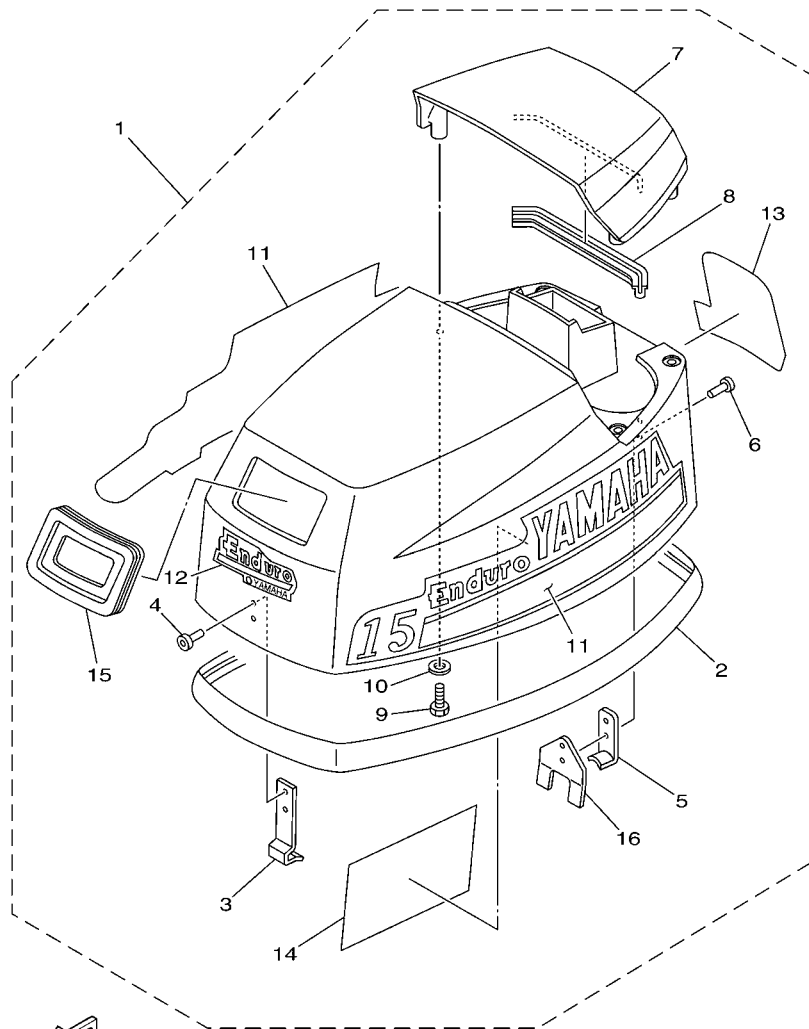

6B81200-C010

FIG. 1 TOP COWLING

REF. NO.	PART NO.	DESCRIPTION	6B76	6B96	6B86	6C06	REMARKS
1	6B7-42610-00-4D	TOP COWLING ASSY	1	1			
	6B8-42610-00-4D	TOP COWLING ASSY			1	1	
2	6B4-42615-00	.SEAL	1	1	1	1	
3	6B4-42651-00	.HOOK	1	1	1	1	
4	90266-04M00	.RIVET	2	2	2	2	
5	6B4-42647-00	.HOLDER, CLAMP BAND	1	1	1	1	
6	90266-04005	.RIVET	2	2	2	2	
7	6B4-42613-00-4D	.MOLDING, AIR DUCT	1	1	1	1	
8	6B4-42628-00	.SEAL	1	1	1	1	
9	97095-06016	.BOLT	4	4	4	4	
10	92995-06600	.WASHER	4	4	4	4	
11	6B3-W0070-H0	.GRAPHIC SET	1	1			
	6B4-W0070-H0	.GRAPHIC SET			1	1	
12	677-42677-J0	.GRAPHIC, FRONT	1	1	1	1	
13	6B7-42678-K0	.GRAPHIC, REAR	1	1			
	6M7-42678-K0	.GRAPHIC, REAR			1	1	
14	6B8-13437-00	.MARK, CAUTION	1	1	1	1	
15	6B4-15761-00	.SEAL, RUBBER 1	1	1	1	1	
16	6B4-42646-00	.PLATE, CLAMP	1	1	1	1	

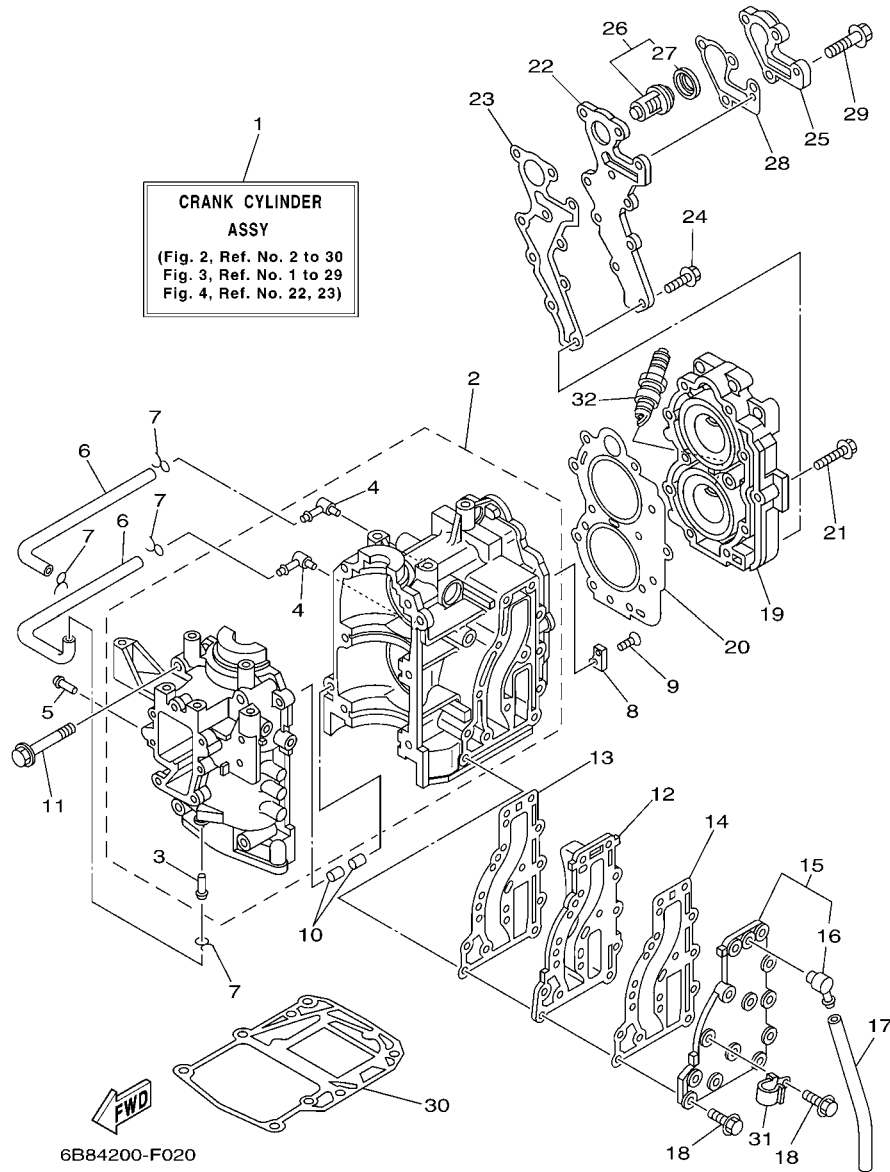

**FIG. 2 CYLINDER & CRANKCASE**

REF. NO.	PART NO.	DESCRIPTION	6B76	6B96	6B86	6C06	REMARKS
1	6B8-W0090-00-1S	CRANK CYLINDER ASSY	1	1	1	1	
2	6B8-15100-00-1S	CRANKCASE ASSY	1	1	1	1	
3	624-14485-00	.PIPE, JOINT	1	1	1	1	
4	650-14485-03	.PIPE, JOINT	2	2	2	2	
5	6H1-14485-00	PIPE, JOINT	1	1	1	1	
6	90445-07M08	HOSE (L220)	2	2	2	2	
7	90467-06016	CLIP	4	4	4	4	
8	682-11325-00	ANODE	1	1	1	1	
9	98780-05015	SCREW, FLAT HEAD	1	1	1	1	
10	93606-12019	PIN, DOWEL	2	2	2	2	
11	90119-08M07	BOLT, WITH WASHER	6	6	6	6	
12	63V-41111-00-1S	INNER COVER, EXHAUST	1	1	1	1	
13	6B4-41112-A0	GASKET, EXHAUST INNER COVER	1	1	1	1	
14	63V-41112-A0	GASKET, EXHAUST INNER COVER	1	1	1	1	
15	63V-41113-00-1S	OUTER COVER, EXHAUST	1	1	1	1	
16	676-11372-00	.NIPPLE, HOSE	1	1	1	1	
17	90445-09104	HOSE (L300)	1	1	1	1	
18	90119-06MA4	BOLT, WITH WASHER	13	13	13	13	
19	6B8-11111-00-1S	HEAD, CYLINDER 1	1	1	1	1	
20	63V-11181-A1	GASKET, CYLINDER HEAD 1	1	1	1	1	
21	90105-07M05	BOLT, FLANGE	11	11	11	11	
22	6B4-11191-00-1S	COVER, CYLINDER HEAD 1	1	1	1	1	
23	6B4-11193-A1	GASKET, HEAD COVER 1	1	1	1	1	
24	90119-06023	BOLT, WITH WASHER	6	6	6	6	
25	682-12413-00-1S	COVER, THERMOSTAT	1	1	1	1	
26	6F5-12411-03	THERMOSTAT	1	1	1	1	
27	6E5-12412-00	.SEAL, THERMOSTAT	1	1	1	1	

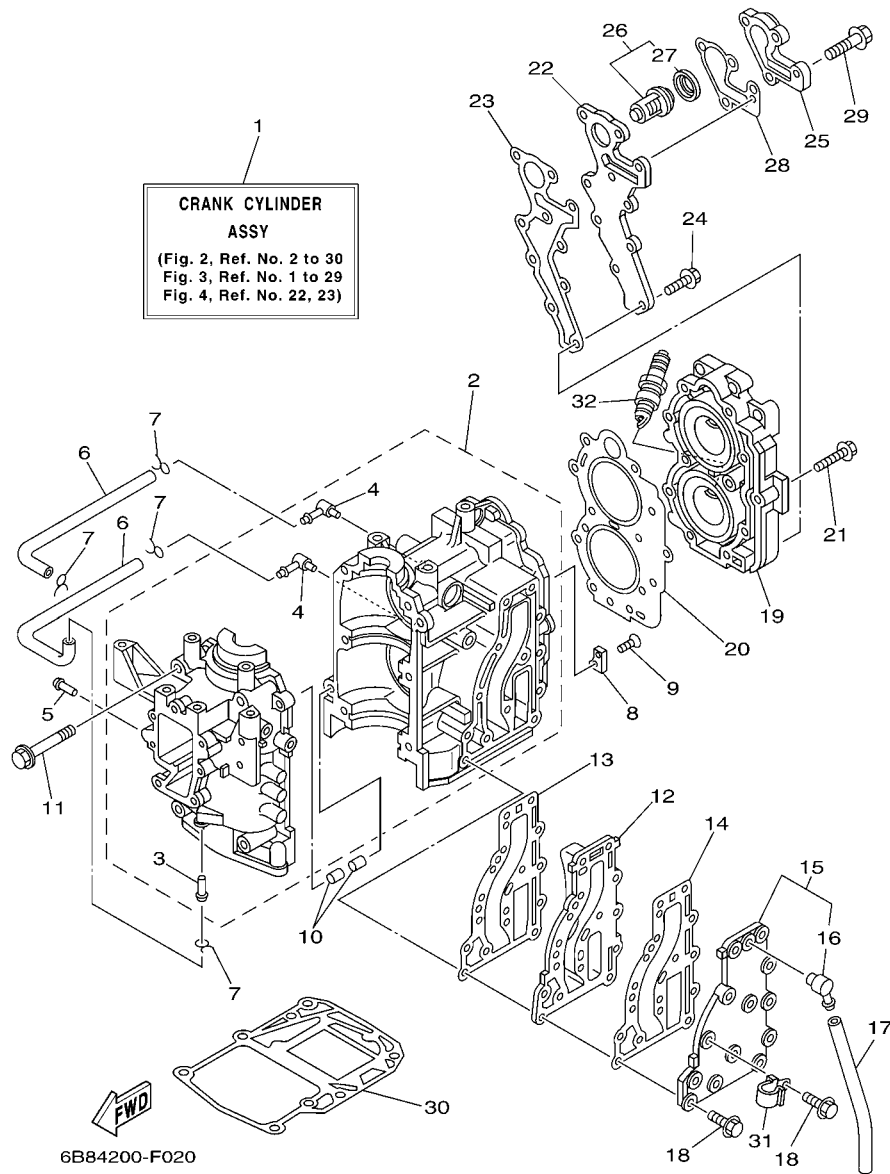

**FIG. 2 CYLINDER & CRANKCASE**

REF. NO.	PART NO.	DESCRIPTION	6B76	6B96	6B86	6C06	REMARKS
			1	1	1	1	
28	682-12414-A1	GASKET, COVER	1	1	1	1	
29	90119-06MA3	BOLT, WITH WASHER	4	4	4	4	
30	6B4-11351-A0	GASKET, CYLINDER	1	1	1	1	
31	90462-06008	CLAMP	1	1	1	1	
32	94702-00217	PLUG, SPARK (NGK B7HS-10)	2	2	2	2	
-----							
-----							
-----							
-----							
-----							
-----							
-----							

FIG. 3 CRANKSHAFT & PISTON

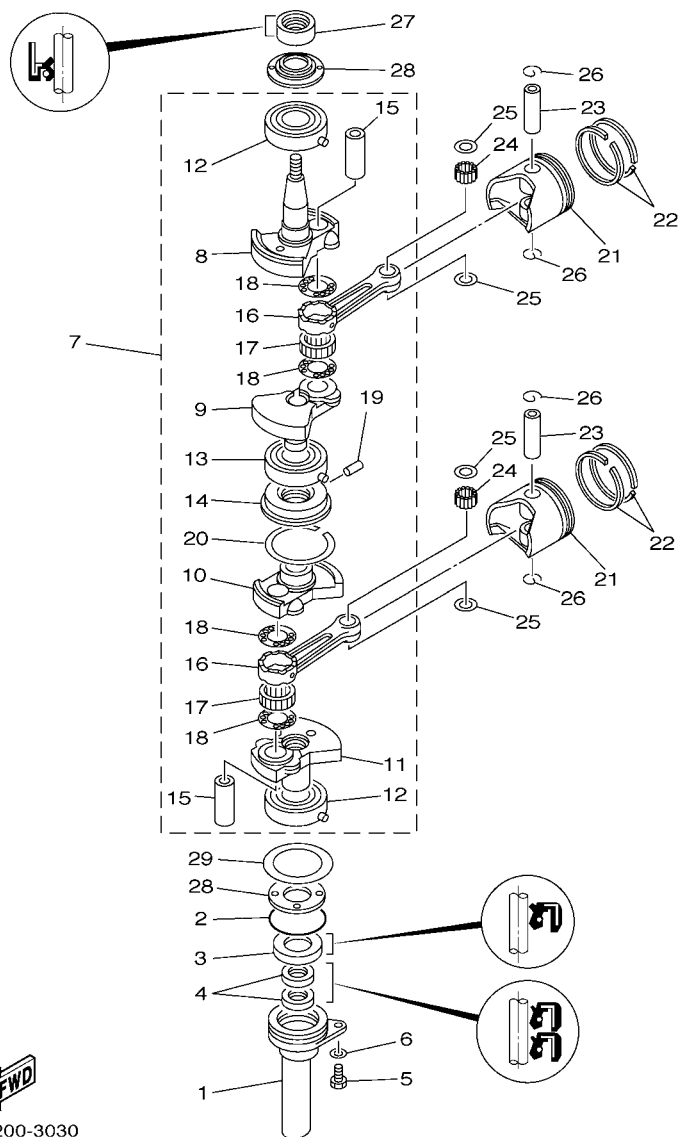

6B31200-3030

REF. NO.	PART NO.	DESCRIPTION	6B76	6B96	6B86	6C06	REMARKS
1	6B4-15396-00-94	HOUSING, OIL SEAL	1	1	1	1	
2	93210-46MH8	O-RING	1	1	1	1	
3	93102-25010	OIL SEAL	1	1	1	1	
4	93101-13M27	OIL SEAL	2	2	2	2	
5	97095-06016	BOLT	1	1	1	1	
6	92995-06600	WASHER	1	1	1	1	
7	6B4-11400-00	CRANKSHAFT ASSY	1	1	1	1	
8	63V-11412-00	.CRANK 1	1	1	1	1	
9	63V-11422-00	.CRANK 2	1	1	1	1	
10	63V-11432-00	.CRANK 3	1	1	1	1	
11	63V-11442-00	.CRANK 4	1	1	1	1	
12	93306-205A1	.BEARING	2	2	2	2	
13	93390-00029	.BEARING	1	1	1	1	
14	63V-11515-02	.SEAL, LABYRINTH 1	1	1	1	1	
15	682-11681-00	.PIN, CRANK 1	2	2	2	2	
16	6K4-11651-00	.ROD, CONNECTING	2	2	2	2	
17	93310-620W5	.BEARING	2	2	2	2	
18	90209-20M23	.WASHER	4	4	4	4	
19	91609-20008	.PIN, SPRING	1	1	1	1	
20	93440-52009	.CIRCLIP	1	1	1	1	
21	6E7-11631-00-97	PISTON (STD)	2	2	2	2	
	6E7-11635-00	PISTON (0.25MM O/S)	2	2	2	2	AP
	6E7-11636-00	PISTON (0.50MM O/S)	2	2	2	2	AP
22	682-11610-01	PISTON RING SET (STD)	2	2	2	2	
	682-11610-11	PISTON RING SET (0.25MM O/S)	2	2	2	2	AP
	682-11610-21	PISTON RING SET (0.50MM O/S)	2	2	2	2	AP
23	634-11633-00	PIN, PISTON	2	2	2	2	



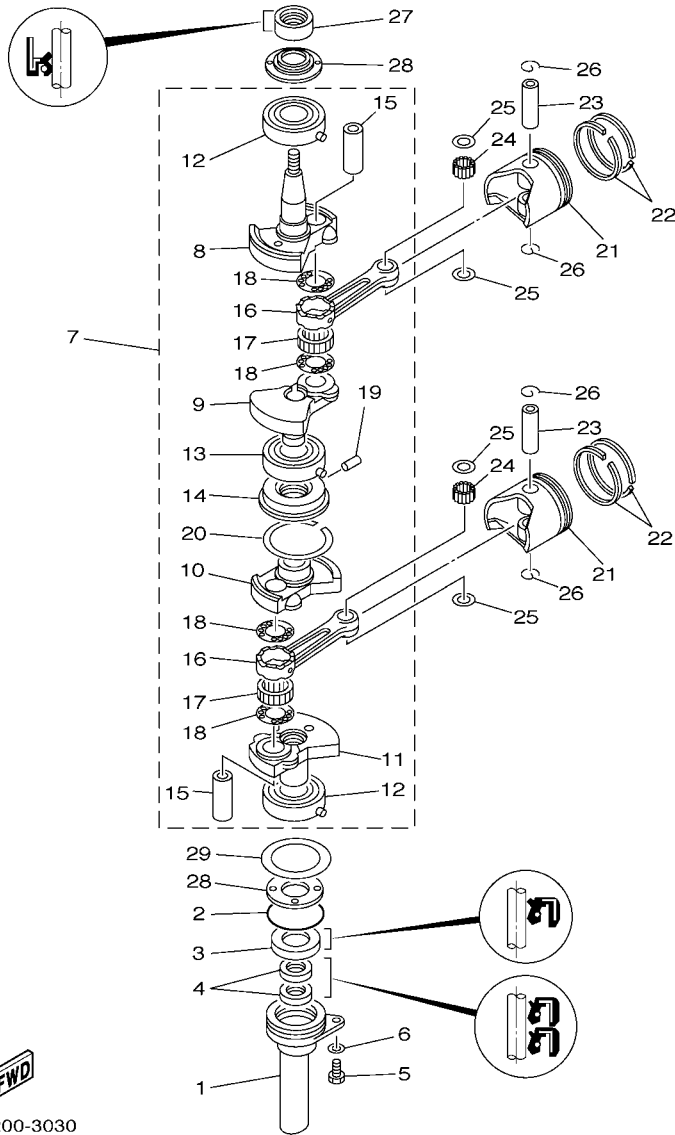

  
 6B31200-3030

**FIG. 3 CRANKSHAFT & PISTON**

REF. NO.	PART NO.	DESCRIPTION	6B76	6B96	6B86	6C06	REMARKS
24	93602-14104	PIN, DOWEL	50	50	50	50	
25	90201-14377	WASHER, PLATE	4	4	4	4	
26	93450-15023	CIRCLIP	4	4	4	4	
27	93110-23M00	OIL SEAL	1	1	1	1	
28	63V-11445-00	SPACER	2	2	2	2	
29	90201-46M29	WASHER, PLATE	1	1	1	1	
-----							
-----							
-----							
-----							
-----							
-----							
-----							
-----							
-----							

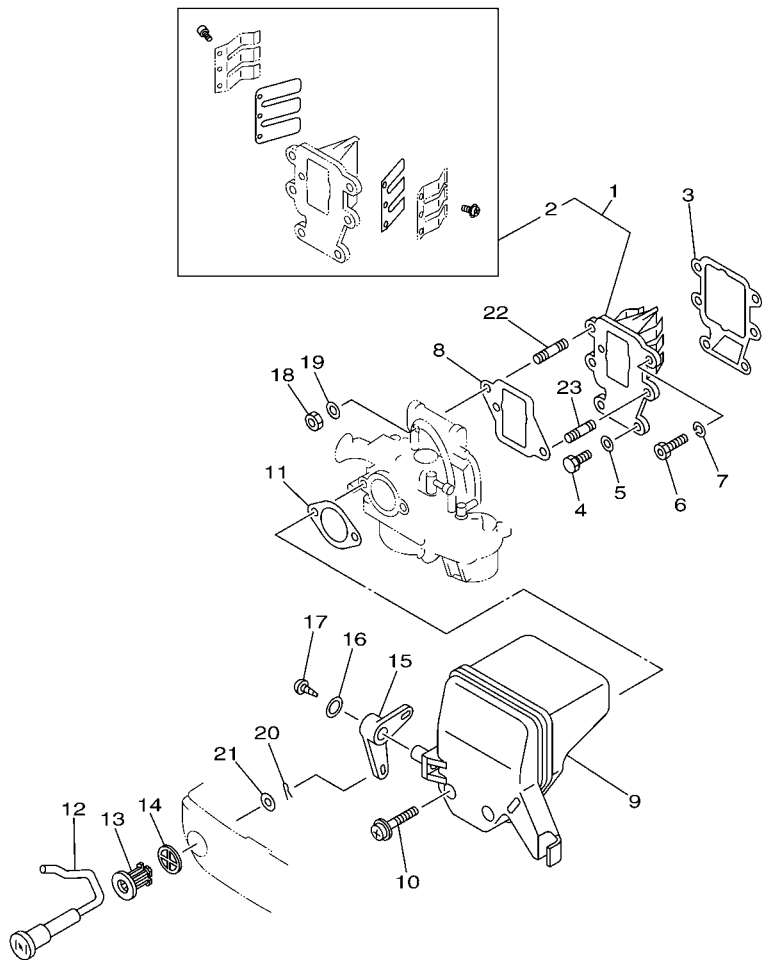

6B81200-C040

FIG. 4 INTAKE

REF. NO.	PART NO.	DESCRIPTION	6B76	6B96	6B86	6C06	REMARKS
1	6B8-13610-00	REED VALVE ASSY	1	1	1	1	
2	6B8-W0004-00	.REED SET	1	1	1	1	
3	682-13621-A1	GASKET, VALVE SEAT	1	1	1	1	
4	97095-06016	BOLT	3	3	3	3	
5	92995-06600	WASHER	3	3	3	3	
6	90101-06128	BOLT	1	1	1	1	
7	92903-06100	WASHER, SPRING	1	1	1	1	
8	677-14198-A1	GASKET	1	1	1	1	
9	6B8-14440-00	SILENCER ASSY, INTAKE	1	1	1	1	
10	90159-05007	SCREW, WITH WASHER	2	2	2	2	
11	6B8-14483-00	GASKET	1	1	1	1	
12	6B8-41271-00	KNOB, CHOKE	1	1	1	1	
13	6B4-41273-00	GROMMET	1	1	1	1	
14	6B4-41274-00	GROMMET 2	1	1	1	1	
15	6M7-41252-00	LEVER, CHOKE 1	1	1	1	1	
16	90201-05M03	WASHER, PLATE	1	1	1	1	
17	90164-05M00	SCREW, TAPPING	1	1	1	1	
18	95380-06700	NUT	2	2	2	2	
19	92995-06600	WASHER	2	2	2	2	
20	90468-10004	CLIP	1	1	1	1	
21	90202-05203	WASHER, PLATE	1	1	1	1	
22	90116-06130	BOLT, STUD	1	1	1	1	
23	95627-06325	BOLT, STUD	1	1	1	1	

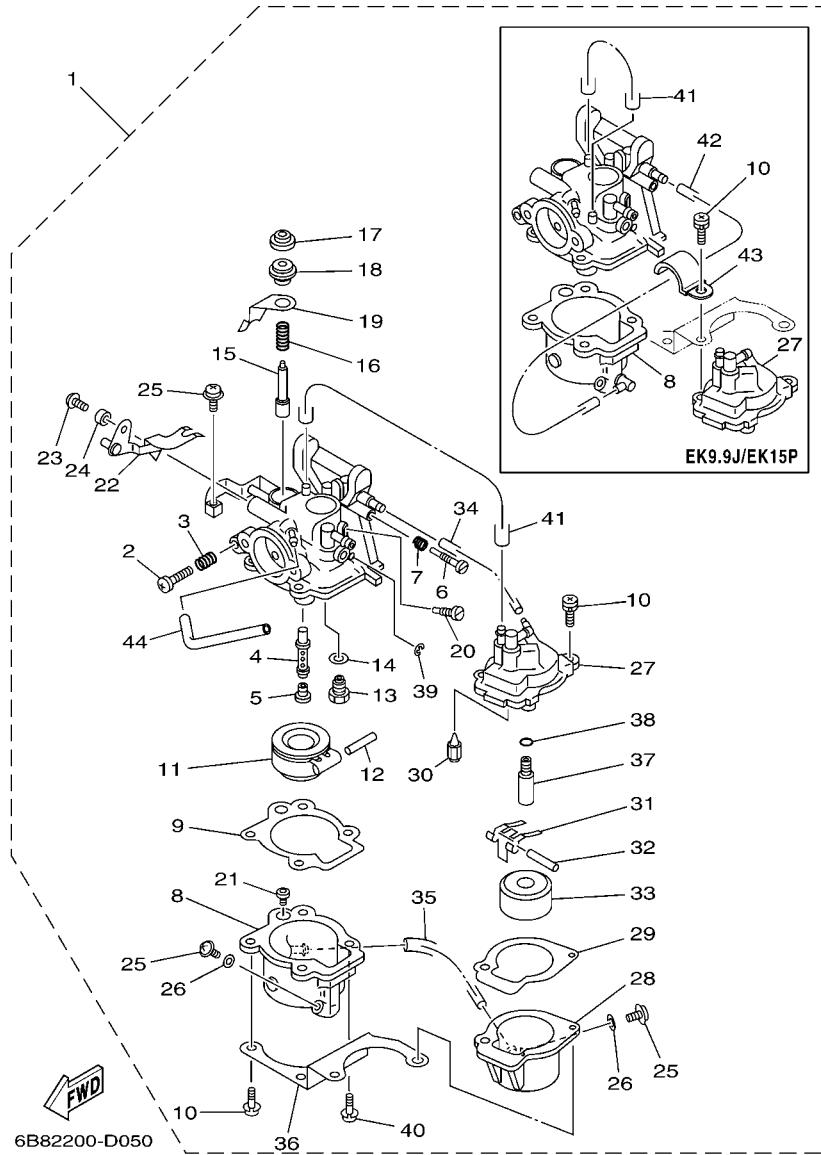

FIG. 5 CARBURETOR

REF. NO.	PART NO.	DESCRIPTION	6B76	6B96	6B86	6C06	REMARKS
1	6B8-14301-00	CARBURETOR ASSY 1	1		1		
	6C0-14301-01	CARBURETOR ASSY 1		1		1	
2	650-14321-01	.SCREW, THROTTLE	1	1	1	1	
3	626-14333-00	.SPRING, THROTTLE STOP	1	1	1	1	
4	6M7-14341-00	.NOZZLE, MAIN	1	1	1	1	
5	648-14343-51	.JET, MAIN (#102)	1		1		
	648-14343-46	.JET, MAIN (# 92)		1		1	
6	647-14323-00	.SCREW, AIR ADJUSTING	1	1	1	1	
7	646-14212-01	.SPRING, PILOT ADJUSTING	1	1	1	1	
8	680-14381-00	.BODY, FLOAT CHAMBER	1		1		
	680-14381-10	.BODY, FLOAT CHAMBER		1		1	
9	650-14384-00	.GASKET, FLOAT CHAMBER	1	1	1	1	
10	97980-04115	.SCREW, WITH WASHER	4	4	4	4	
11	6B8-14385-00	.FLOAT	1	1	1	1	
12	626-14386-10	.PIN, FLOAT	1	1	1	1	
13	677-14390-12	.NEEDLE VALVE ASSY	1	1	1	1	
14	626-14398-00	.GASKET	1	1	1	1	
15	626-14371-00	.PLUNGER, STARTER	1	1	1	1	
16	626-14335-00	.SPRING, PLUNGER	1	1	1	1	
17	626-14373-00	.COVER, PLUNGER CAP	1	1	1	1	
18	626-14374-00	.CAP, PLUNGER	1	1	1	1	
19	626-14378-00	.PLATE, STARTER LEVER 1	1	1	1	1	
20	648-14342-23	.JET, PILOT (# 46)	1	1	1	1	
21	648-14344-25	.JET, STARTER (# 50)	1		1		
	6C0-14344-40	.JET, STARTER (# 80)		1		1	
22	6M7-14376-00	.LEVER, STARTER 2	1	1	1	1	
23	650-14327-01	.SCREW	1	1	1	1	

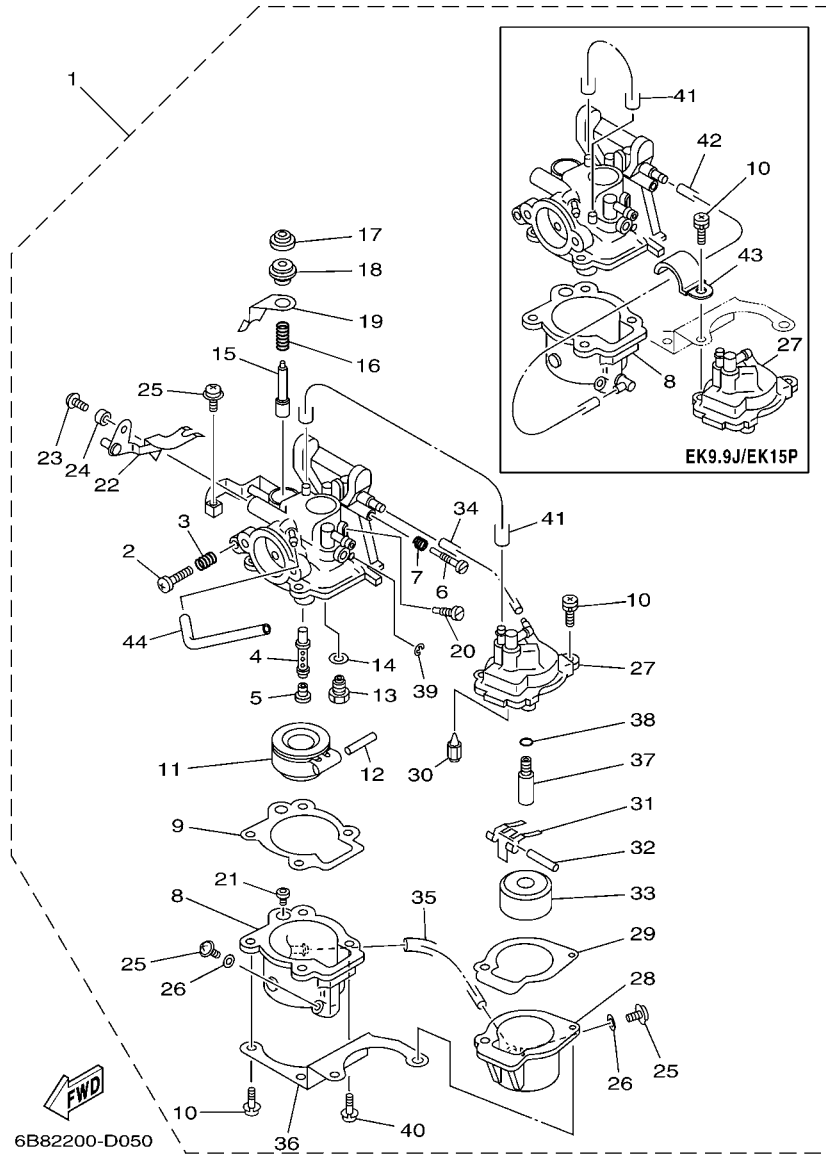

FIG. 5 CARBURETOR

REF. NO.	PART NO.	DESCRIPTION	6B76	6B96	6B86	6C06	REMARKS
24	650-14349-00	.PIPE	1	1	1	1	
25	97980-04005	.SCREW, WITH WASHER	3	3	3	3	
26	6L2-14398-00	.GASKET	2	2	2	2	
27	65G-14182-00	.COVER, FLOAT CHAMBER	1	1			
	65G-14182-20	.COVER, FLOAT CHAMBER		1		1	
28	680-14181-00	.BODY, FLOAT CHAMBER 1	1	1	1	1	
29	652-14384-00	.GASKET, FLOAT CHAMBER	1	1	1	1	
30	6F5-14392-00	.VALVE, NEEDLE	1	1	1	1	
31	652-14387-40	.ARM, FLOAT	1	1	1	1	
32	6M7-14386-00	.PIN, FLOAT	1	1	1	1	
33	652-14385-00	.FLOAT	1	1	1	1	
34	6A4-14348-00	.PIPE 1	1	1			
35	6M7-14348-00	.PIPE 1	1	1	1	1	
36	65G-14346-00	.PLATE	1	1	1	1	
37	652-14353-34	.JET, PILOT (# 68)	1	1	1	1	
38	652-14147-00	.O-RING	1	1	1	1	
39	93430-04301	.CIRCLIP	1	1	1	1	
40	97980-04112	.SCREW, WITH WASHER	2	2	2	2	
41	65G-14348-00	.PIPE 1	1	1			
	65G-14348-00	.PIPE 1		2		2	
42	65G-14348-11	.PIPE 1		1		1	
43	65G-14261-00	.HOLDER		1		1	
44	6B8-14349-00	.PIPE	1	1	1	1	

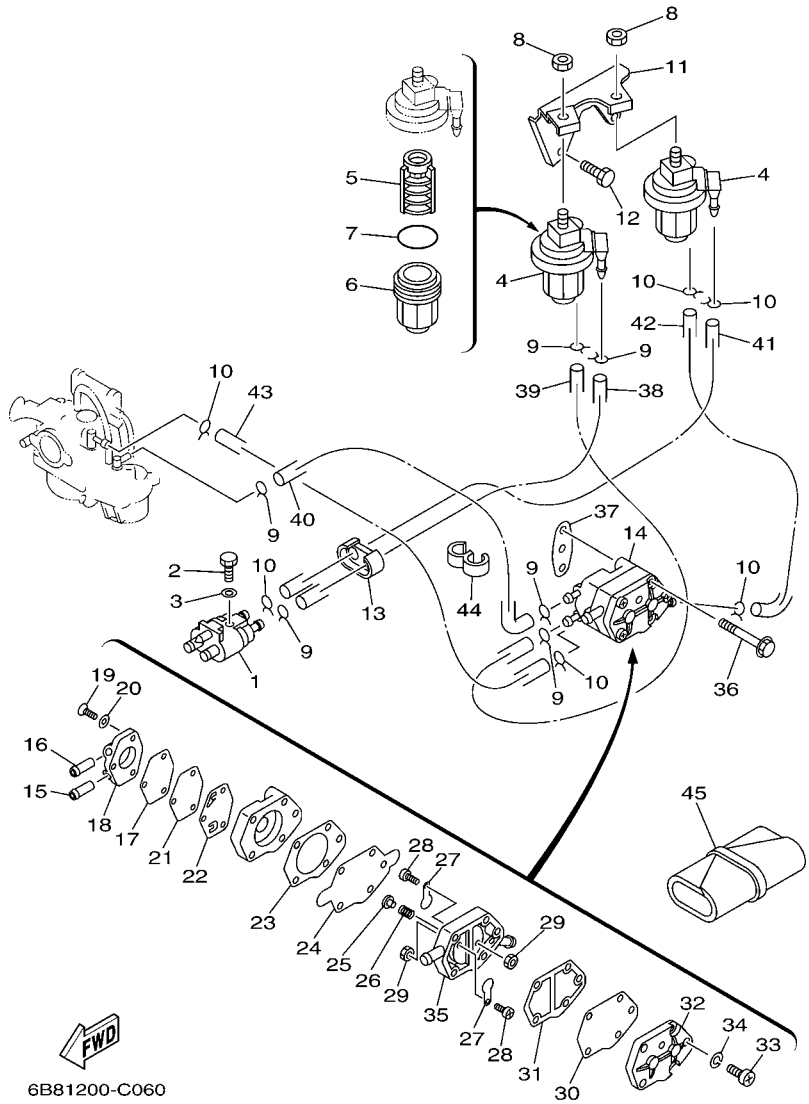
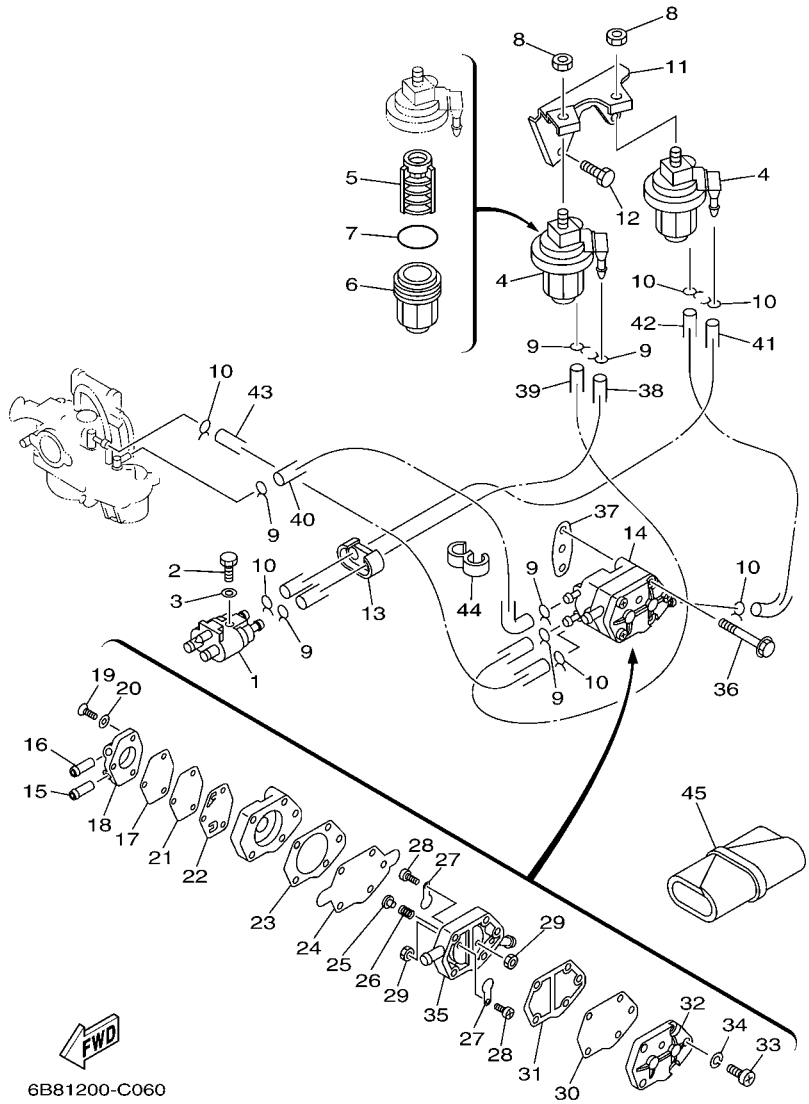

FIG. 6 FUEL 1

REF. NO.	PART NO.	DESCRIPTION	6B76	6B96	6B86	6C06	REMARKS
1	680-24304-01	FUEL PIPE JOINT COMP. 1	1	1	1	1	
2	97095-06020	BOLT	1	1	1	1	
3	92995-06600	WASHER	1	1	1	1	
4	61N-24560-00	FILTER ASSY	2	2	2	2	
5	61N-24563-00	.ELEMENT, FILTER	1	1	1	1	
6	61N-24521-00	.CUP, FILTER	1	1	1	1	
7	93210-32738	.O-RING	1	1	1	1	
8	95380-08600	NUT	2	2	2	2	
9	90467-08004	CLIP	6	6	6	6	
10	90467-09M03	CLIP	6	6	6	6	
11	6B8-24566-00	BRACKET, FILTER	1	1	1	1	
12	97013-06012	BOLT	2	2	2	2	
13	6A4-24329-00	SEAL	1	1	1	1	
14	6A4-24410-06	FUEL PUMP ASSY	1	1	1	1	
15	652-24461-00	.PIPE, JOINT	1	1	1	1	
16	62C-24461-00	.PIPE, JOINT	1	1	1	1	
17	652-24471-10	.DIAPHRAGM	1	1	1	1	
18	652-24415-01	.BODY 4	1	1	1	1	
19	98780-04010	.SCREW, FLAT HEAD	3	3	3	3	
20	92990-04500	.WASHER	3	3	3	3	
21	6A4-24471-00	.DIAPHRAGM	1	1	1	1	
22	652-24432-00	.GASKET, FUEL PUMP 2	1	1	1	1	
23	648-24434-01	.GASKET, BODY	1	1	1	1	
24	648-24411-00	.DIAPHRAGM	1	1	1	1	
25	648-24424-00	.SEAT, SPRING	1	1	1	1	
26	648-24423-00	.SPRING, DIAPHRAGM	1	1	1	1	
27	6A0-24421-01	.VALVE, CHECK	2	2	2	2	



6B81200-C060

FIG. 6 FUEL 1

REF. NO.	PART NO.	DESCRIPTION	6B76	6B96	6B86	6C06	REMARKS
28	6A0-14325-00	.SCREW, PAN HEAD	2	2	2	2	
29	95380-03600	.NUT	2	2	2	2	
30	663-24411-00	.DIAPHRAGM	1	1	1	1	
31	648-24435-02	.GASKET, BODY 2	1	1	1	1	
32	6A0-24413-00	.BODY 2	1	1	1	1	
33	98503-05028	.SCREW, PAN HEAD	3	3	3	3	
34	92990-05100	.WASHER, SPRING	3	3	3	3	
35	6A0-24412-02	.BODY 1	1	1	1	1	
36	97595-06550	BOLT, WITH WASHER	2	2	2	2	
37	650-24431-A0	GASKET, FUEL PUMP 1	1	1	1	1	
38	90445-09104	HOSE (L300)	1	1	1	1	
39	61A-24314-00	PIPE 4	1	1	1	1	
40	688-24314-00	PIPE 4	1	1	1	1	
41	6B8-24311-00	PIPE, FUEL 1	1	1	1	1	
42	6B8-24312-00	PIPE 2	1	1	1	1	
43	90445-100E9	HOSE (L155)	1	1	1	1	
44	90464-09M21	CLAMP	1	1	1	1	
45	63V-28100-A0	TOOL KIT	1	1	1	1	

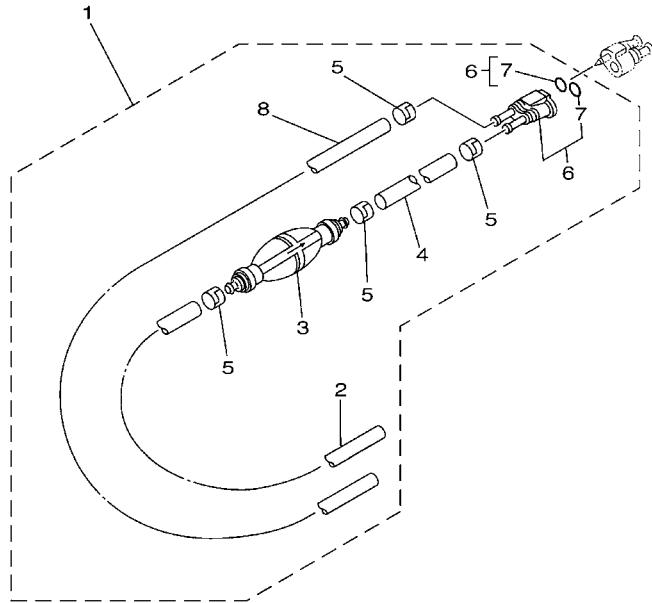

6801200-2070

FIG. 7 FUEL 2

REF. NO.	PART NO.	DESCRIPTION	6B76	6B96	6B86	6C06	REMARKS
1	6Y3-24306-04	FUEL PIPE COMP. 1		1		1	AP
2	90445-11M06	.HOSE (L2050)		1		1	
3	61J-24360-00	.PRIMER PUMP ASSY		1		1	
4	90445-11M05	.HOSE (L850)		1		1	
5	650-24351-01	.BAND 1		4		4	
6	680-24305-01	.FUEL PIPE JOINT COMP. 2		1		1	
7	93210-08287	..O-RING		2		2	
8	90445-11M81	.HOSE (L3000)		1		1	

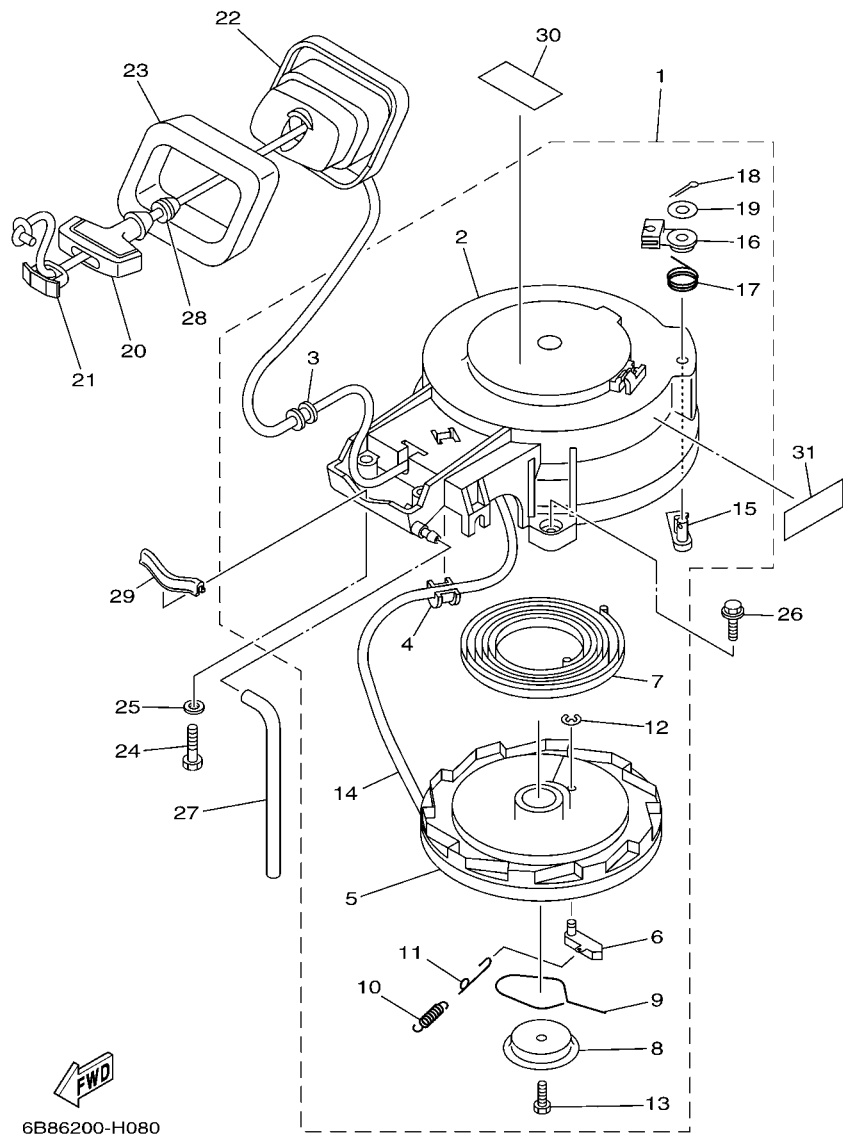

6B86200-H080

\*1: CUT FROM 50M ROLLS, PART NO.90890-44373, CUTTING LENGTH 1.8M

FIG. 8 STARTER

REF. NO.	PART NO.	DESCRIPTION	6B76	6B96	6B86	6C06	REMARKS
1	6B4-15710-00	STARTER ASSY	1	1	1	1	
2	6B4-15711-00	.CASE, STARTER	1	1	1	1	
3	63V-15764-00	.COLLAR 1	1	1	1	1	
4	68T-15764-00	.COLLAR 1	1	1	1	1	
5	63V-15714-00	.DRUM, SHEAVE	1	1	1	1	
6	63V-15741-00	.PAWL, DRIVE	1	1	1	1	
7	63V-15713-00	.SPRING, STARTER	1	1	1	1	
8	63V-15716-00	.PLATE, DRIVE	1	1	1	1	
9	63V-15705-01	.SPRING, DRIVE PAWL	1	1	1	1	
10	63V-15767-01	.SPRING	1	1	1	1	
11	68T-15784-00	.SPRING, RETURN	1	1	1	1	
12	63V-15744-00	.CIRCLIP	1	1	1	1	
13	63V-15768-00	.BOLT	1	1	1	1	
14	*	.WIRE, STARTER (L:1800MM)	1	1	1	1	*1
15	63V-15794-00	.STOPPER	1	1	1	1	
16	63V-15748-00	.PLUNGER, STARTER STOP	1	1	1	1	
17	63V-15734-00	.SPRING, RETURN	1	1	1	1	
18	91490-16018	.PIN, COTTER	1	1	1	1	
19	63V-15726-00	.WASHER, FLAT	1	1	1	1	
20	6G1-15755-00	HANDLE, STARTER	1	1	1	1	
21	6G1-15779-00	COVER	1	1	1	1	
22	6B4-15758-00-4D	GUIDE, ROPE	1	1	1	1	
23	6B4-15762-00	SEAL, RUBBER 2	1	1	1	1	
24	97095-06030	BOLT	2	2	2	2	
25	92995-06600	WASHER	2	2	2	2	
26	90119-06M82	BOLT, WITH WASHER	3	3	3	3	
27	6J8-24311-00	PIPE, FUEL 1	1	1	1	1	



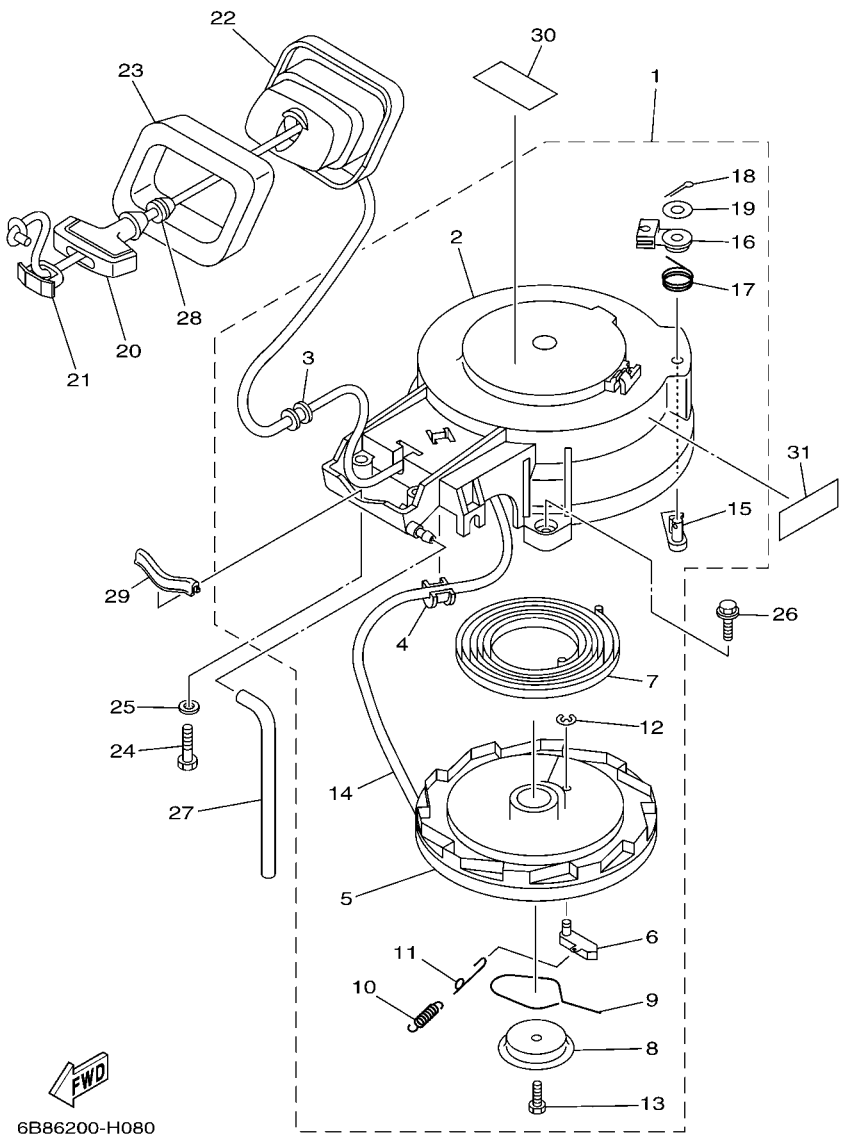

6B86200-H080

\*1: CUT FROM 50M ROLLS, PART NO.90890-44373, CUTTING LENGTH 1.8M

FIG. 8 STARTER

REF. NO.	PART NO.	DESCRIPTION	6B76	6B96	6B86	6C06	REMARKS
28	6A0-15789-00	DAMPER	1	1	1	1	
29	6B4-15663-00	SEAL	1	1	1	1	
30	6AH-81995-40	LABEL, WARNING	1	1	1	1	
31	6AH-81994-40	LABEL, SAFETY	1	1	1	1	

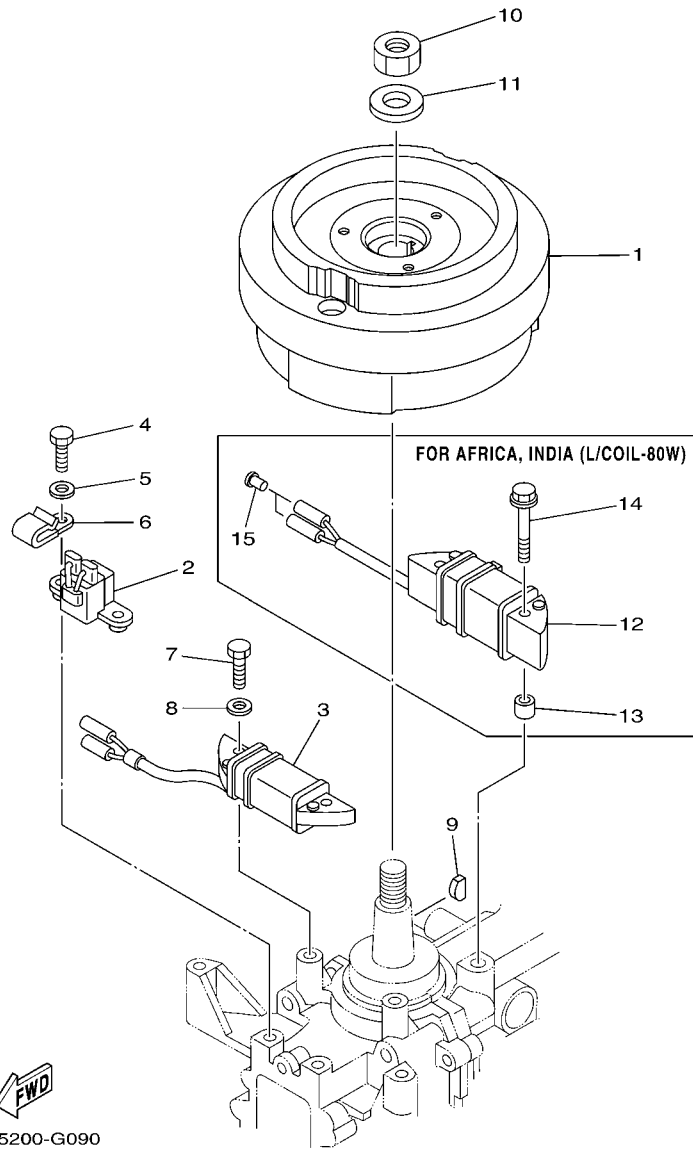
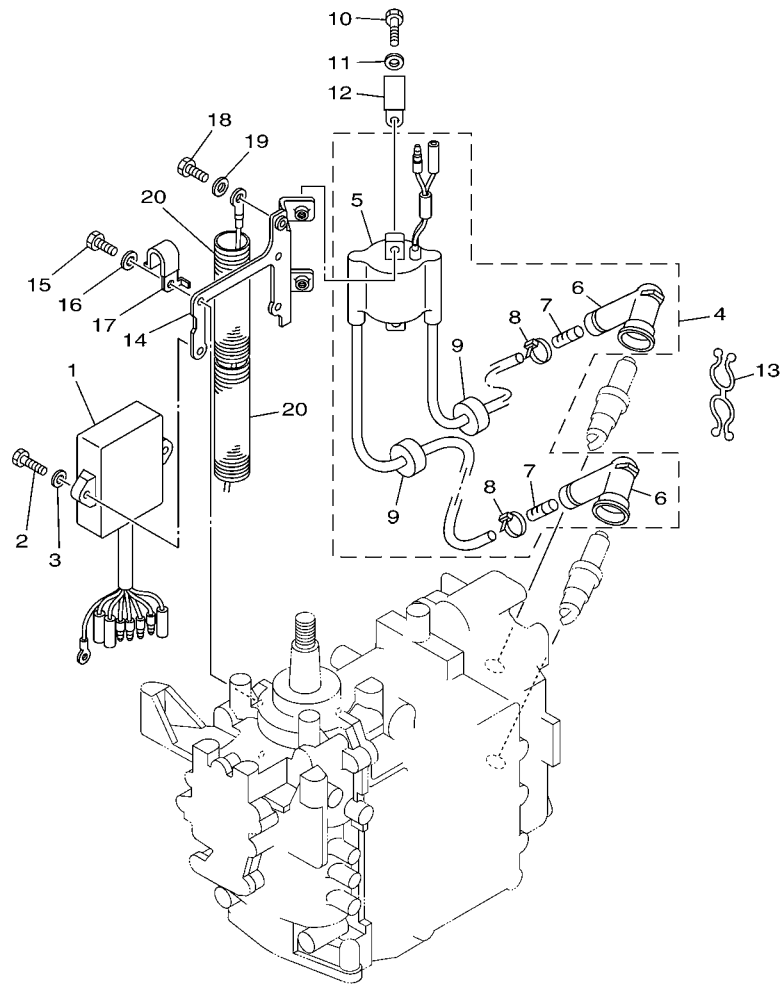

FIG. 9 GENERATOR

REF. NO.	PART NO.	DESCRIPTION	6B76	6B96	6B86	6C06	REMARKS
1	6B4-85550-01	ROTOR ASSY	1	1	1	1	
2	6B4-85580-00	COIL, PULSER	1	1	1	1	
3	6B4-85520-00	COIL, CHARGE	1	1	1	1	
4	97095-06016	BOLT	2	2	2	2	
5	92995-06600	WASHER	2	2	2	2	
6	90465-06M90	CLAMP	1	1	1	1	
7	97095-06020	BOLT	2	2	2	2	
8	92995-06600	WASHER	2	2	2	2	
9	90280-05013	KEY, WOODRUFF	1	1	1	1	
10	90170-12066	NUT	1	1	1	1	
11	90201-12472	WASHER, PLATE	1	1	1	1	
12	63V-85533-00	COIL, LIGHTING	1	1			FOR AFR,IDN
13	90387-06M24	COLLAR	2	2			FOR AFR,IDN
14	90119-06M40	BOLT, WITH WASHER	2	2			FOR AFR,IDN
15	703-82119-00	COVER, LEAD WIRE	2	2			FOR AFR,IDN



6B84200-F100

FIG. 10 ELECTRICAL

REF. NO.	PART NO.	DESCRIPTION	6B76	6B96	6B86	6C06	REMARKS
1	6B8-85540-00	C.D.I. UNIT ASSY	1	1	1	1	
2	97095-06020	BOLT	2	2	2	2	
3	92995-06600	WASHER	2	2	2	2	
4	6B4-85530-00	IGNITION COIL ASSY	1	1	1	1	
5	6B4-85570-00	.IGNITION COIL ASSY	1	1	1	1	
6	62E-82371-11	.CAP, PLUG	2	2	2	2	
7	62E-8231X-00	.TERMINAL 1	2	2	2	2	
8	90465-11M10	.CLAMP	2	2	2	2	
9	90480-25161	.GROMMET	2	2	2	2	
10	97095-06016	BOLT	2	2	2	2	
11	92995-06600	WASHER	2	2	2	2	
12	90465-06M90	CLAMP	1	1	1	1	
13	90464-08M02	CLAMP	1	1	1	1	
14	6B4-82316-00	BRACKET, IGNITION COIL	1	1	1	1	
15	97095-06014	BOLT	2	2	2	2	
16	92995-06600	WASHER	2	2	2	2	
17	90465-08M99	CLAMP	1	1	1	1	
18	97095-06010	BOLT	1	1	1	1	
19	92995-06600	WASHER	1	1	1	1	
20	6N7-83557-00	TUBE (I.DIA:22MM)	2	2	2	2	

FIG. 11 BOTTOM COWLING

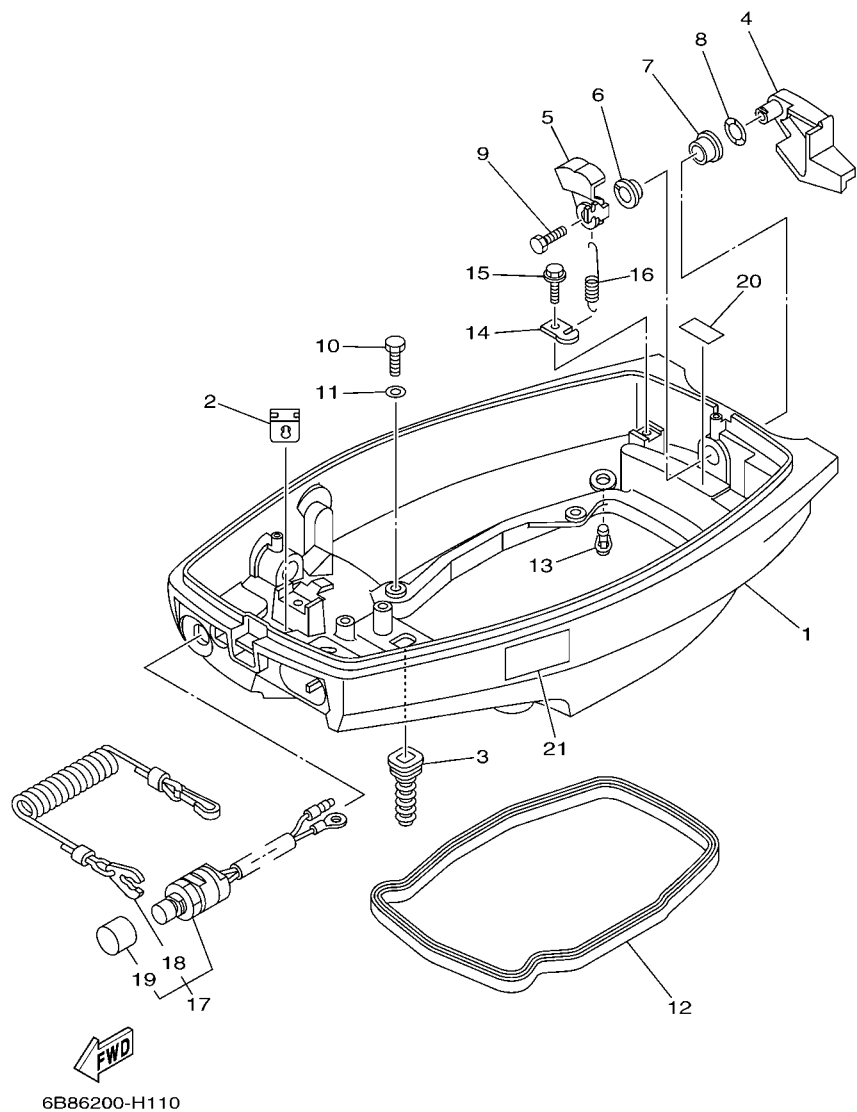

REF. NO.	PART NO.	DESCRIPTION	6B76	6B96	6B86	6C06	REMARKS
1	6B4-42711-00-4D	COWLING, BOTTOM 1	1	1	1	1	
2	61N-26326-00	GROMMET	1	1	1	1	
3	6B4-42727-00	GROMMET	1	1	1	1	
4	6B4-42815-00-4D	LEVER, CLAMP	1	1	1	1	
5	6B4-42816-00	LEVER, CLAMP	1	1	1	1	
6	90386-12M45	BUSH	1	1	1	1	
7	90386-12MA2	BUSH	1	1	1	1	
8	90206-12052	WASHER, WAVE	1	1	1	1	
9	97095-06014	BOLT	1	1	1	1	
10	97095-06016	BOLT	4	4	4	4	
11	92995-06600	WASHER	4	4	4	4	
12	6B4-42716-00	RUBBER, SEAL 1	1	1	1	1	
13	6H3-44391-01	NIPPLE, HOSE	1	1	1	1	
14	66T-43144-00	HOOK, SPRING	1	1	1	1	
15	90109-06M80	BOLT	1	1	1	1	
16	90506-18009	SPRING, TENSION	1	1	1	1	
17	689-82575-04	ENGINE STOP SWITCH ASSY	1	1	1	1	
18	682-82556-00	.LANYARD, STOP SWITCH	1	1	1	1	
19	689-8257Y-00	.CAP	1	1	1	1	
20	6E7-42791-00	MARK 1	1	1	1	1	
21	6AH-42794-40	LABEL, WARNING (GENERAL)	1	1	1	1	

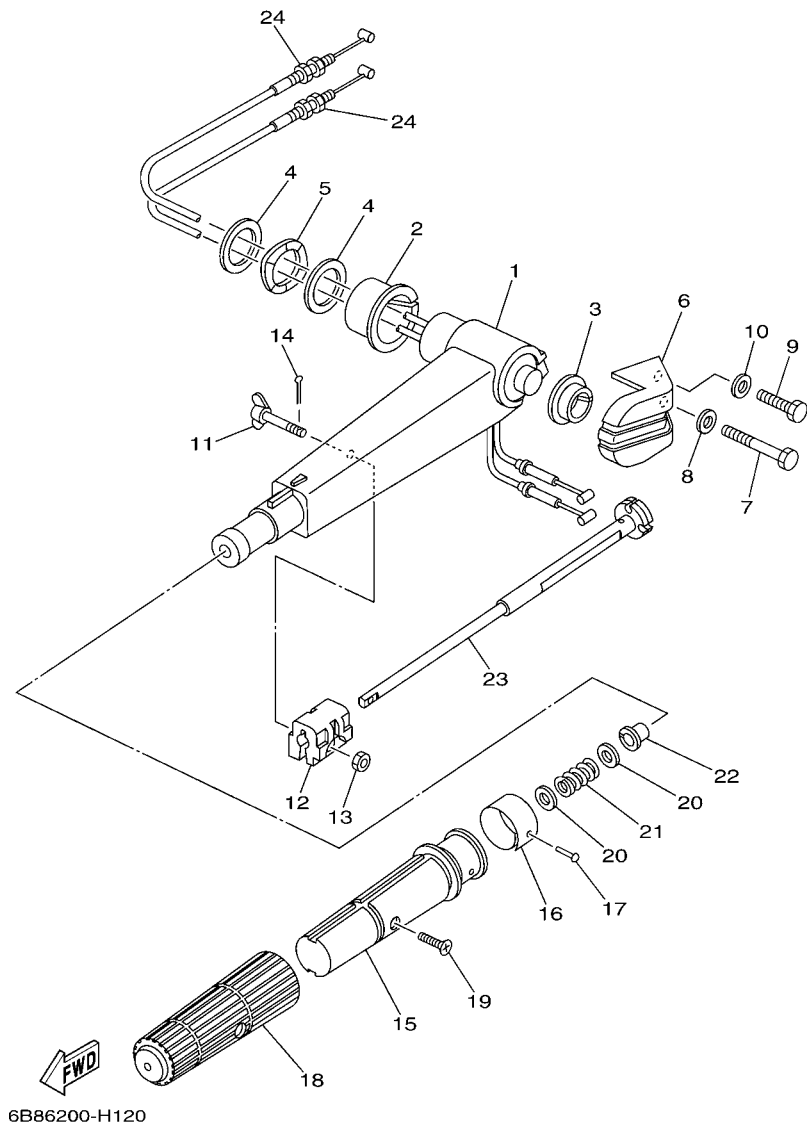
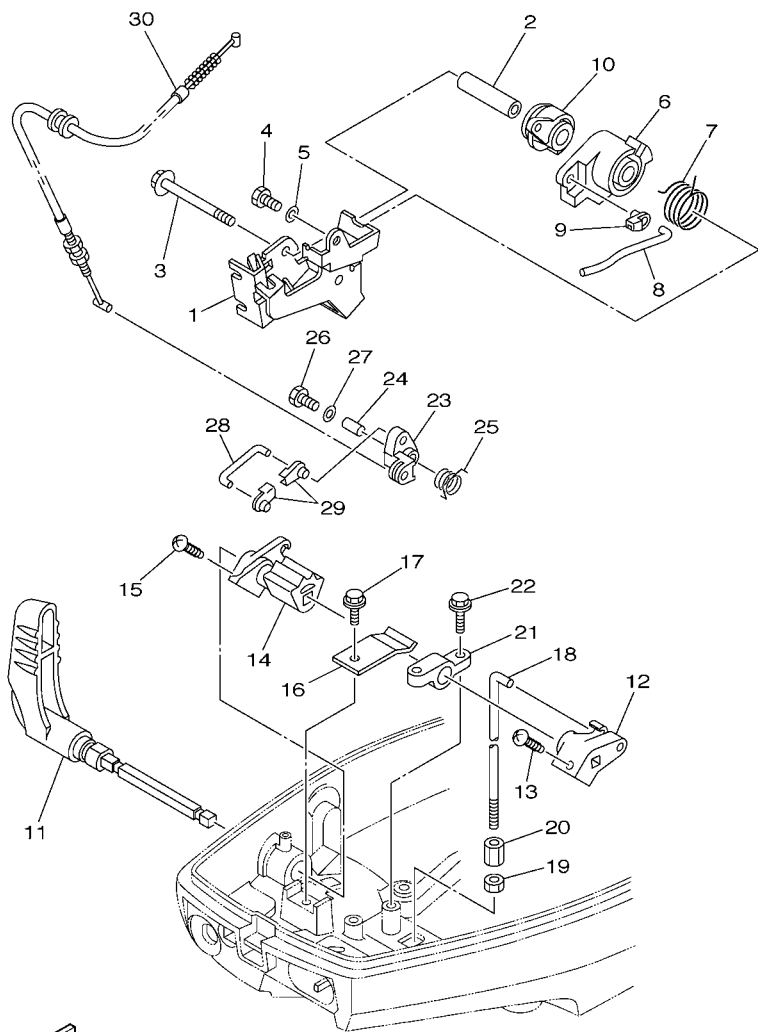

FIG. 12 STEERING

REF. NO.	PART NO.	DESCRIPTION	6B76	6B96	6B86	6C06	REMARKS
1	6B4-42111-00-4D	HANDLE, STEERING	1	1	1	1	
2	90381-35001	BUSH, SOLID	1	1	1	1	
3	90381-20001	BUSH, SOLID	1	1	1	1	
4	90201-28013	WASHER, PLATE	2	2	2	2	
5	90206-28001	WASHER, WAVE	1	1	1	1	
6	6B4-42131-00-4D	COVER, HANDLE STEERING	1	1	1	1	
7	97095-08055	BOLT	1	1	1	1	
8	92995-08600	WASHER	1	1	1	1	
9	97095-08030	BOLT	1	1	1	1	
10	92995-08600	WASHER	1	1	1	1	
11	6B4-42125-00	BOLT, FRICTION ADJUSTING	1	1	1	1	
12	6B4-42126-00	FRICTION, STEERING HANDLE GRIP	1	1	1	1	
13	95380-06600	NUT, HEXAGON	1	1	1	1	
14	91490-16010	PIN, COTTER	1	1	1	1	
15	6B4-42119-00	GRIP, STEERING HANDLE	1	1	1	1	
16	6F5-42137-00	INDICATOR, THROTTLE	1	1	1	1	
17	90269-02M09	RIVET	1	1	1	1	
18	6G1-42177-00	RUBBER, HANDLE	1	1	1	1	
19	90149-05M13	SCREW	1	1	1	1	
20	90201-10M02	WASHER, PLATE	2	2	2	2	
21	90501-23215	SPRING, COMPRESSION	1	1	1	1	
22	90386-08032	BUSH	1	1	1	1	
23	6B4-42138-00	LEVER, THROTTLE	1	1	1	1	
24	6B4-26301-00	THROTTLE CABLE ASSY	2	2	2	2	

**FIG. 13 CONTROL**



6B31200-3120

REF. NO.	PART NO.	DESCRIPTION	6B76	6B96	6B86	6C06	REMARKS
1	63V-14497-02	STAY, THROTTLE WIRE	1	1	1	1	
2	90387-06M50	COLLAR	1	1	1	1	
3	95895-06065	BOLT, FLANGE	1	1	1	1	
4	97095-06012	BOLT	1	1	1	1	
5	92995-06600	WASHER	1	1	1	1	
6	6B4-41283-00	LEVER, FREE ACCEL.	1	1	1	1	
7	90508-20M38	SPRING, TORSION	1	1	1	1	
8	63V-41211-00	LINK, ACCEL.	1	1	1	1	
9	6J8-41262-00	JOINT, CHOKE LEVER	1	1	1	1	
10	6B4-41638-00	PULLEY	1	1	1	1	
11	6B4-44111-00-4D	HANDLE, GEAR SHIFT	1	1	1	1	
12	6B4-44121-00	LEVER, SHIFT ROD	1	1	1	1	
13	97780-40520	SCREW, TAPPING	1	1	1	1	
14	6B4-44125-00	LEVER, SHIFT ROD	1	1	1	1	
15	97780-40520	SCREW, TAPPING	1	1	1	1	
16	6B4-44116-00	SPRING	1	1	1	1	
17	90109-06M80	BOLT	1	1	1	1	
18	6B4-44143-00	ROD, SHIFT	1	1	1	1	
19	95380-06700	NUT	1	1	1	1	
20	61N-44146-00	CONNECTOR, SHIFT ROD	1	1	1	1	
21	6B4-41662-00	BRACKET 2	1	1	1	1	
22	90109-06M81	BOLT	2	2	2	2	
23	6B4-15746-00	ARM	1	1	1	1	
24	90387-06M06	COLLAR	1	1	1	1	
25	90508-08M39	SPRING, TORSION	1	1	1	1	
26	97095-06020	BOLT	1	1	1	1	
27	92995-06600	WASHER	1	1	1	1	

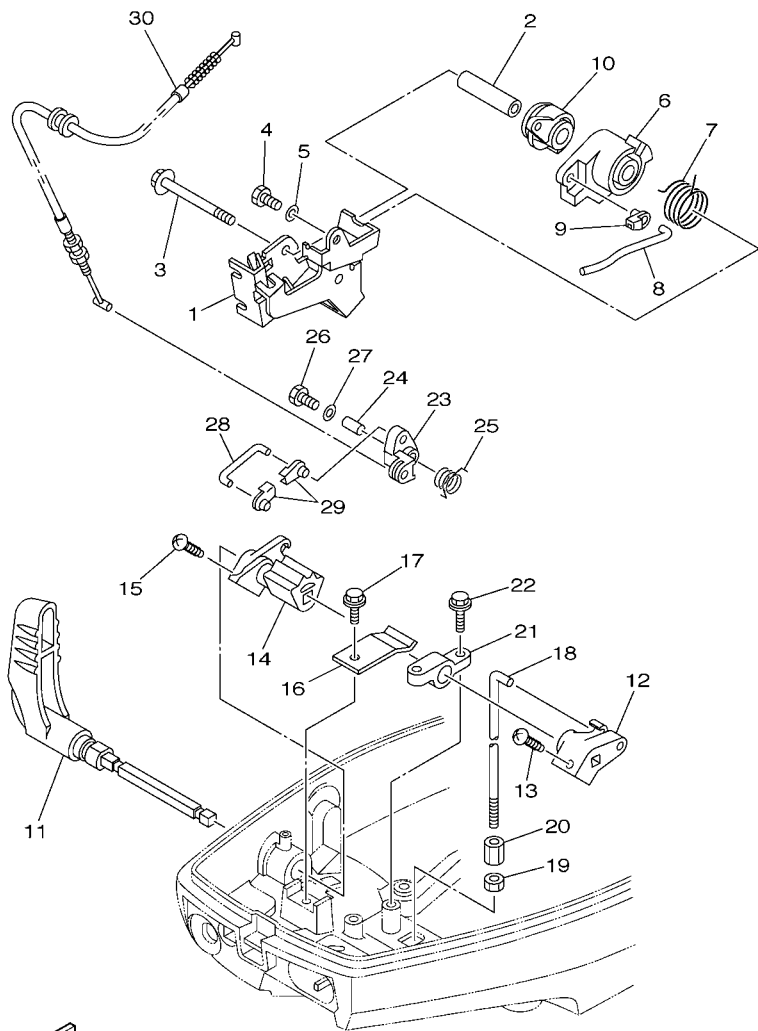

6B31200-3120

FIG. 13 CONTROL

REF. NO.	PART NO.	DESCRIPTION	6B76	6B96	6B86	6C06	REMARKS
28	6L2-15747-00	LINK	1	1	1	1	
29	6J8-41262-00	JOINT, CHOKE LEVER	2	2	2	2	
30	6B4-15770-00	CABLE COMP., STARTER STOP	1	1	1	1	

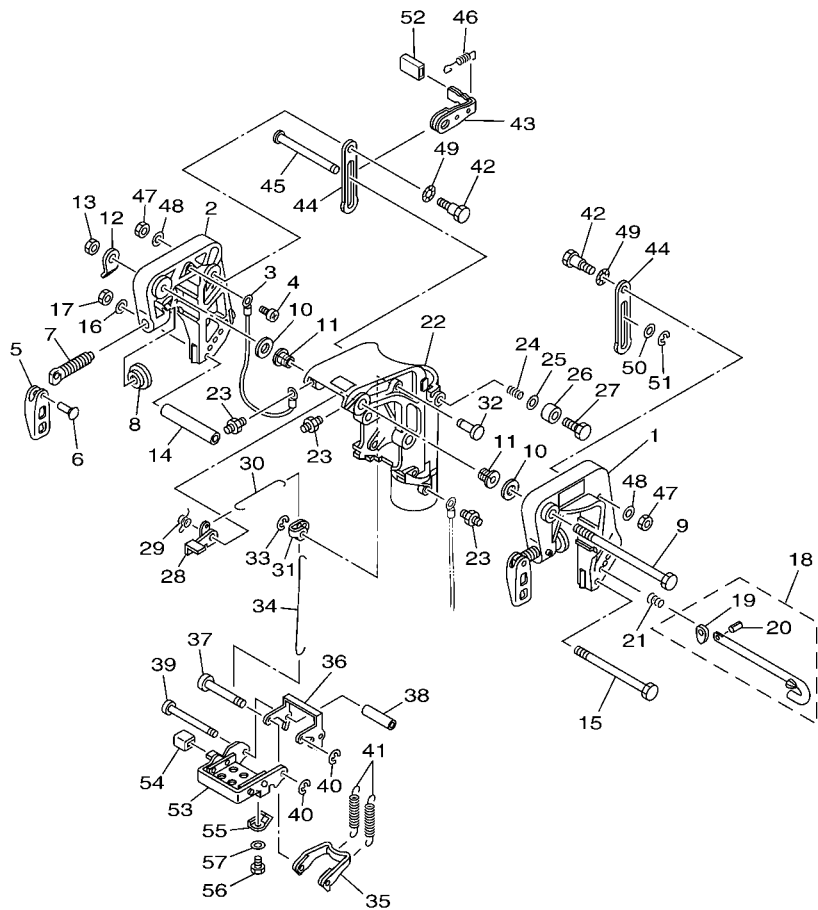

**FWD**  
6B81200-C140

**FIG. 14 BRACKET 1**

REF. NO.	PART NO.	DESCRIPTION	6B76	6B96	6B86	6C06	REMARKS
1	682-43111-05-4D	BRACKET, CLAMP 1	1	1	1	1	
2	682-43112-05-4D	BRACKET, CLAMP 2	1	1	1	1	
3	6E5-82148-00	WIRE, LEAD 4	1	1	1	1	
4	97885-06008	SCREW, PAN HEAD	1	1	1	1	
5	663-43118-01-4D	HANDLE, TRANSOM CLAMP	2	2	2	2	
6	90243-04007	PIN	2	2	2	2	
7	6E7-43116-00	SCREW, TRANSOM CLAMP	2	2	2	2	
8	648-43114-01	PAD, TRANSOM CLAMP	2	2	2	2	
9	90101-12013	BOLT	1	1	1	1	
10	90201-12018	WASHER, PLATE	2	2	2	2	
11	90381-12001	BUSH, SOLID	2	2	2	2	
12	6B4-43113-00	PLATE, CLAMP BRACKET	1	1	1	1	
13	95780-12300	NUT, FLANGE	1	1	1	1	
14	90387-06M13	COLLAR	1	1	1	1	
15	90101-06M29	BOLT	1	1	1	1	
16	92990-06600	WASHER, PLATE	1	1	1	1	
17	95380-06700	NUT	1	1	1	1	
18	689-43160-00	TILT ROD ASSY	1	1	1	1	
19	689-43165-00	.PLATE, TILT LOCK	1	1	1	1	
20	91690-30008	.PIN, SPRING	1	1	1	1	
21	90502-10M07	SPRING, CONICAL	1	1	1	1	
22	682-43311-06-4D	BRACKET, SWIVEL 1	1	1	1	1	
23	93700-06M03	NIPPLE, GREASE	3	3	3	3	
24	90501-18M00	SPRING, COMPRESSION	1	1	1	1	
25	92990-08600	WASHER, PLATE	1	1	1	1	
26	676-43373-00	SEAL, DAMPER	1	1	1	1	
27	97075-08025	BOLT	1	1	1	1	



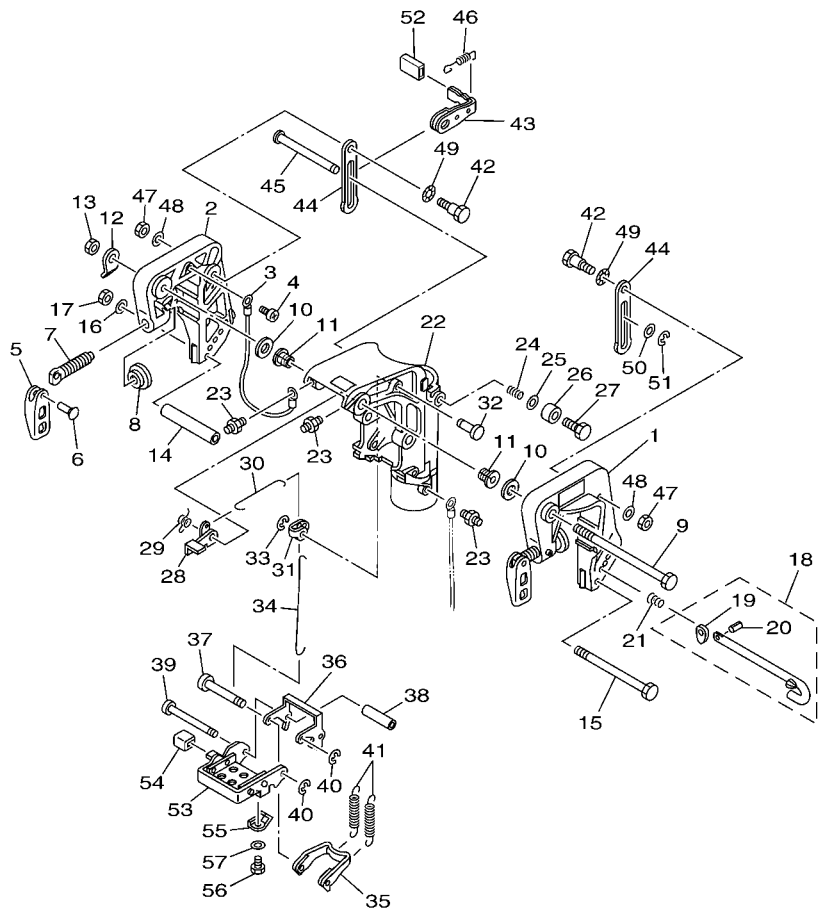

  
 6B81200-C140

**FIG. 14 BRACKET 1**

REF. NO.	PART NO.	DESCRIPTION	6B76	6B96	6B86	6C06	REMARKS
28	6B4-43631-00	LEVER, TILT	1	1	1	1	
29	90508-14018	SPRING, TORSION	1	1	1	1	
30	682-43616-00	ROD, TILT LOCK	1	1	1	1	
31	682-43641-01	LEVER, TILT	1	1	1	1	
32	90249-06M23	PIN	1	1	1	1	
33	99080-05600	CIRCLIP	1	1	1	1	
34	682-43617-00	ROD, TILT LOCK	1	1	1	1	
35	682-43614-01	PLATE, TILT LOCK	1	1	1	1	
36	682-43615-02	PLATE, TILT LOCK	1	1	1	1	
37	682-43611-01	SHAFT, TILT LOCK	1	1	1	1	
38	90387-06M20	COLLAR	1	1	1	1	
39	682-43659-01	SHAFT, REVERSE LOCK	1	1	1	1	
40	99080-05600	CIRCLIP	2	2	2	2	
41	90506-26M01	SPRING, TENSION	2	2	2	2	
42	90109-06M05	BOLT	2	2	2	2	
43	6B4-43181-00	LEVER, TILT STOP	1	1	1	1	
44	6B4-43627-00	STOPPER	2	2	2	2	
45	90249-10003	PIN	1	1	1	1	
46	90506-12002	SPRING, TENSION	1	1	1	1	
47	95680-06100	NUT, U	2	2	2	2	
48	92990-06600	WASHER, PLATE	2	2	2	2	
49	90206-10M24	WASHER, WAVE	2	2	2	2	
50	90202-10M56	WASHER, PLATE	1	1	1	1	
51	99080-09600	CIRCLIP	1	1	1	1	
52	682-43318-01	COVER	1	1	1	1	
53	6B4-43681-00	LEVER, SHALLOW WATER DRIVE 1	1	1	1	1	
54	682-43318-01	COVER	1	1	1	1	

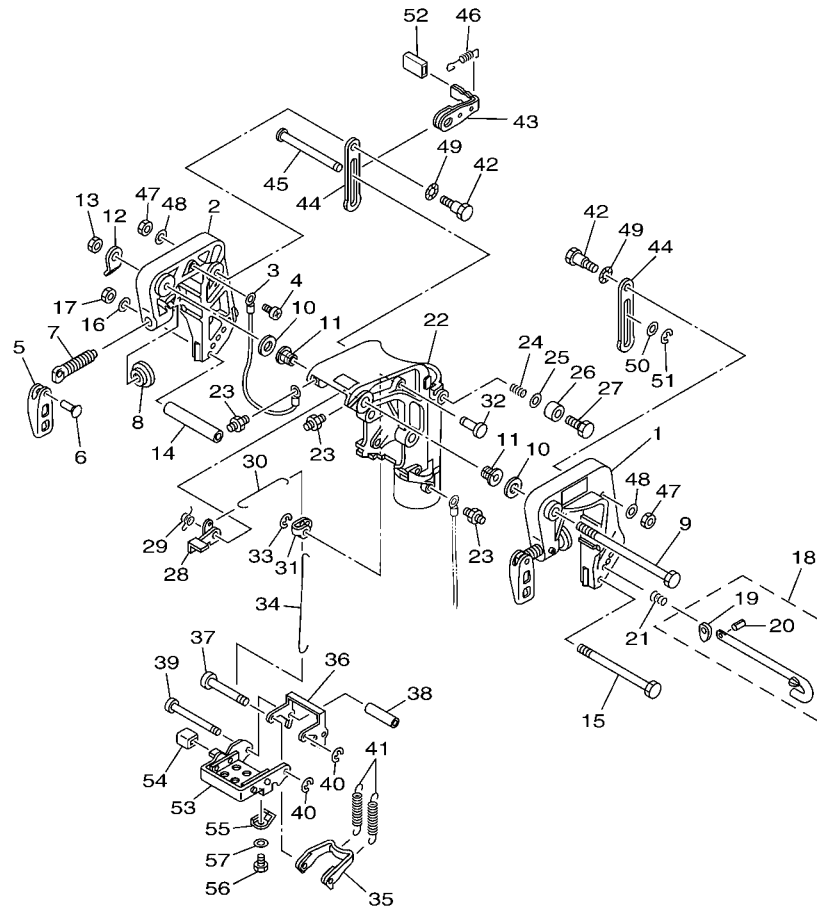

6B81200-C140

FIG. 14 BRACKET 1

REF. NO.	PART NO.	DESCRIPTION	6B76	6B96	6B86	6C06	REMARKS
55	682-43643-00	SPRING	1	1	1	1	
56	97095-06008	BOLT	1	1	1	1	
57	92990-06600	WASHER, PLATE	1	1	1	1	

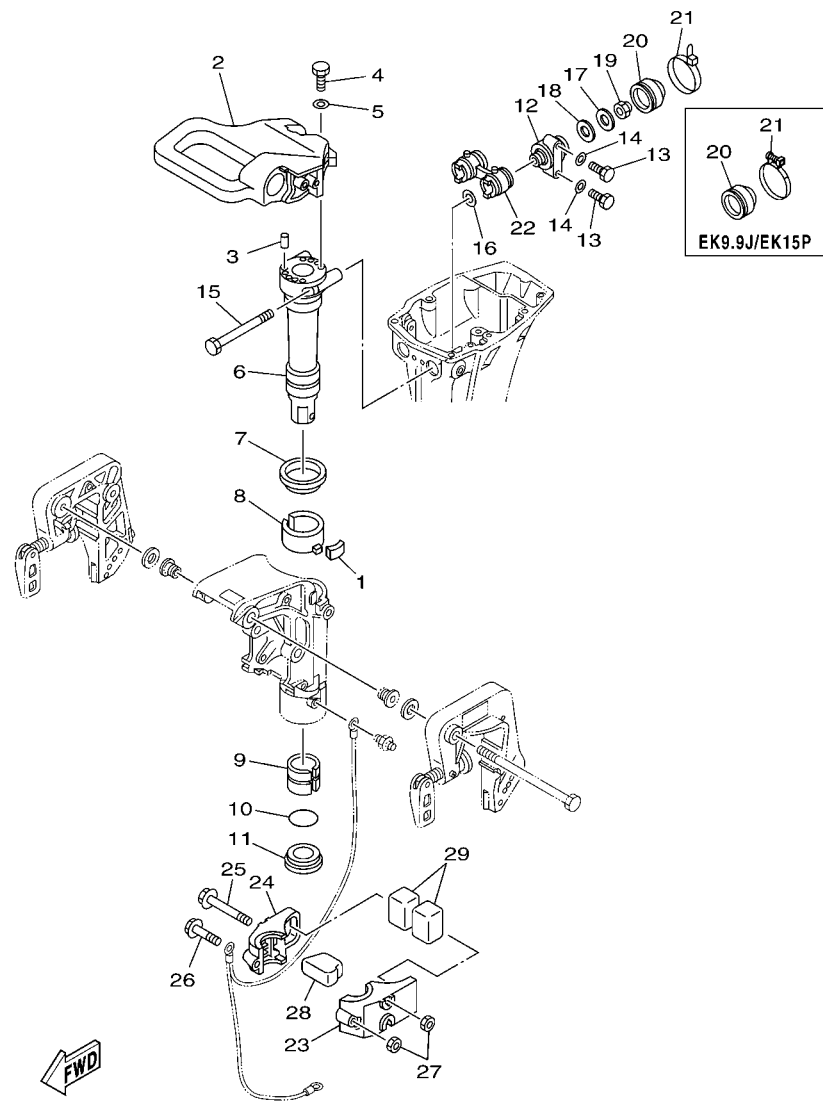

6B85200-G150

FIG. 15 BRACKET 2

REF. NO.	PART NO.	DESCRIPTION	6B76	6B96	6B86	6C06	REMARKS
1	648-42528-00	PLATE, FRICTION	1	1	1	1	
2	6B4-42511-00-4D	BRACKET, STEERING	1	1	1	1	
3	93606-12019	PIN, DOWEL	2	2	2	2	
4	97095-06025	BOLT	3	3	3	3	
5	92995-06600	WASHER	3	3	3	3	
6	682-42521-00-94	SHAFT, STEERING PIVOT	1	1	1	1	
7	90209-52M01	WASHER	1	1	1	1	
8	682-42537-00	BUSHING, PIVOT SHAFT	1	1	1	1	
9	90386-40M09	BUSH	1	1	1	1	
10	93210-40M10	O-RING	1	1	1	1	
11	90386-40M08	BUSH	1	1	1	1	
12	682-44514-01-94	MOUNT DAMPER, UPPER SIDE	2	2	2	2	
13	97095-06025	BOLT	4	4	4	4	
14	92995-06600	WASHER	4	4	4	4	
15	90101-08M30	BOLT	2	2	2	2	
16	90201-08M12	WASHER, PLATE	2	2	2	2	
17	90201-08M13	WASHER, PLATE	2	2	2	2	
18	90202-13M02	WASHER, PLATE	2	2	2	2	
19	90185-08057	NUT, SELF-LOCKING	2	2	2	2	
20	682-44522-01	SEAL	2		2		
	682-44522-10	SEAL		2		2	
21	90465-11M52	CLAMP	2		2		
	6B9-42821-00	BAND, CLAMP		2		2	
22	682-44521-01	SEAL	1	1	1	1	
23	682-44551-02-4D	HOUSING, LOWER MOUNT RUBBER	1	1	1	1	
24	682-44552-02-4D	HOUSING, LOWER MOUNT RUBBER	1	1	1	1	
25	90119-08M45	BOLT, WITH WASHER	2	2	2	2	

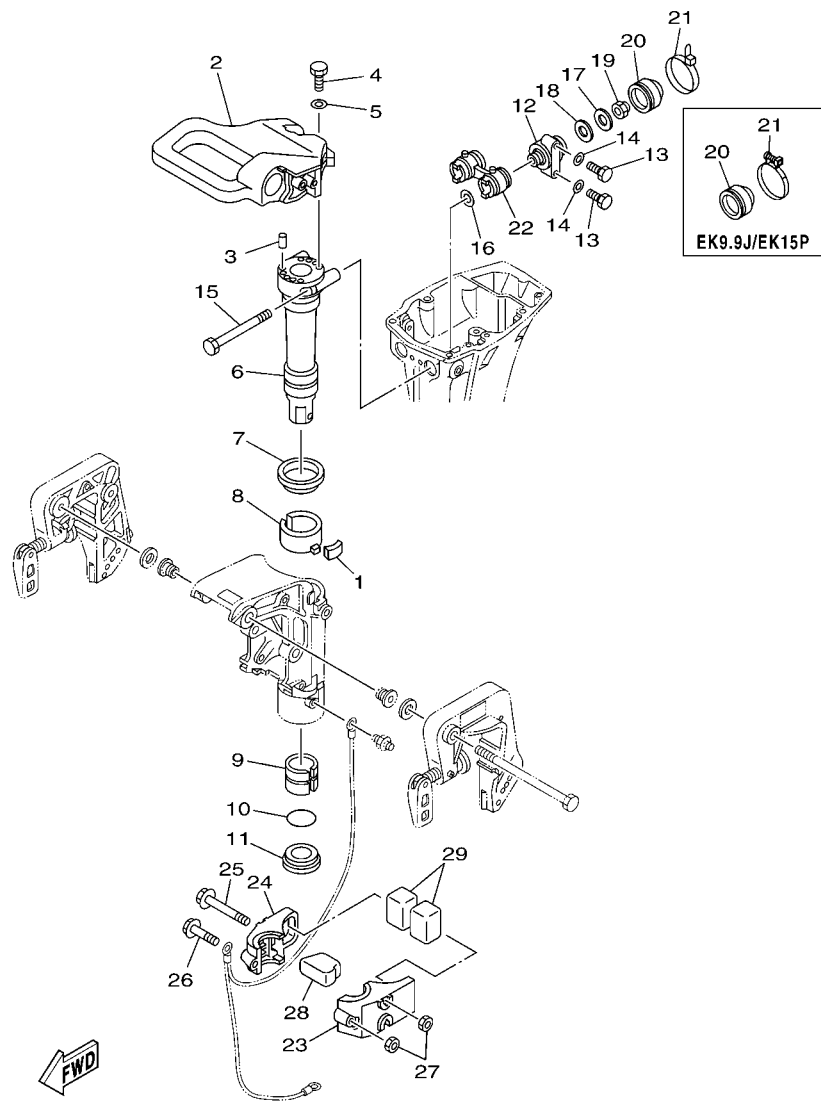

FIG. 15 BRACKET 2

REF. NO.	PART NO.	DESCRIPTION	6B76	6B96	6B86	6C06	REMARKS
26	97575-08555	BOLT, WITH WASHER	1	1	1	1	
27	95380-08700	NUT	3	3	3	3	
28	682-44557-00	MOUNT DAMPER, LOWER FRONT	1	1	1	1	
29	6B4-44555-30	MOUNT DAMPER, LOWER SIDE	2	2	2	2	L(22.4")
-----							
-----							
-----							
-----							
-----							
-----							
-----							
-----							
-----							

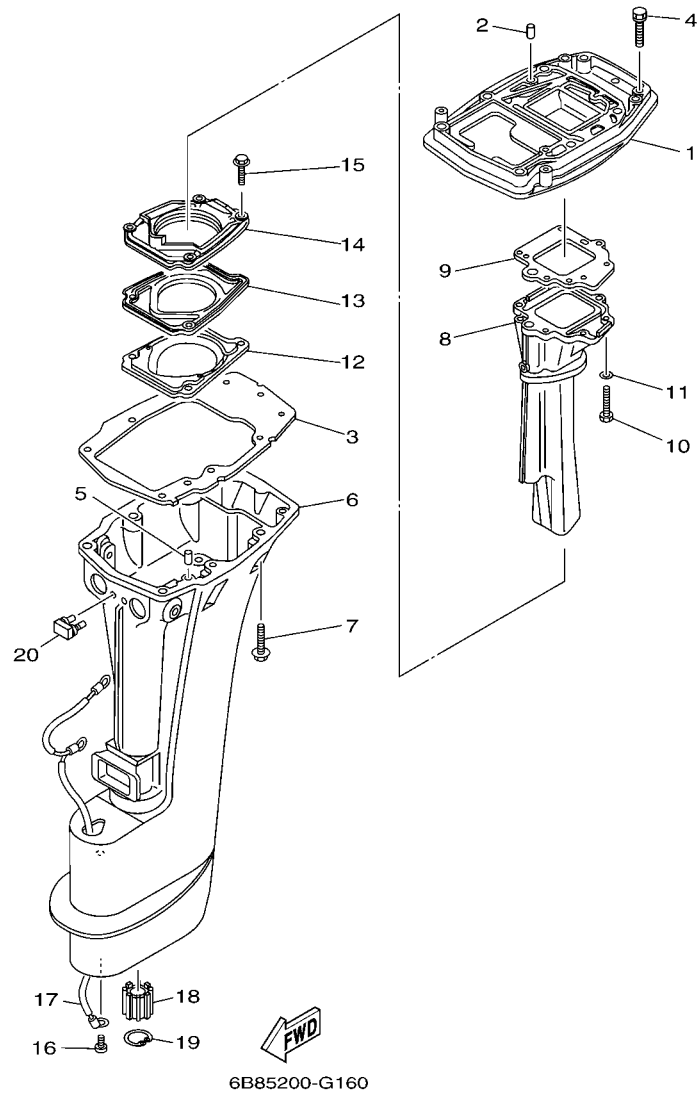
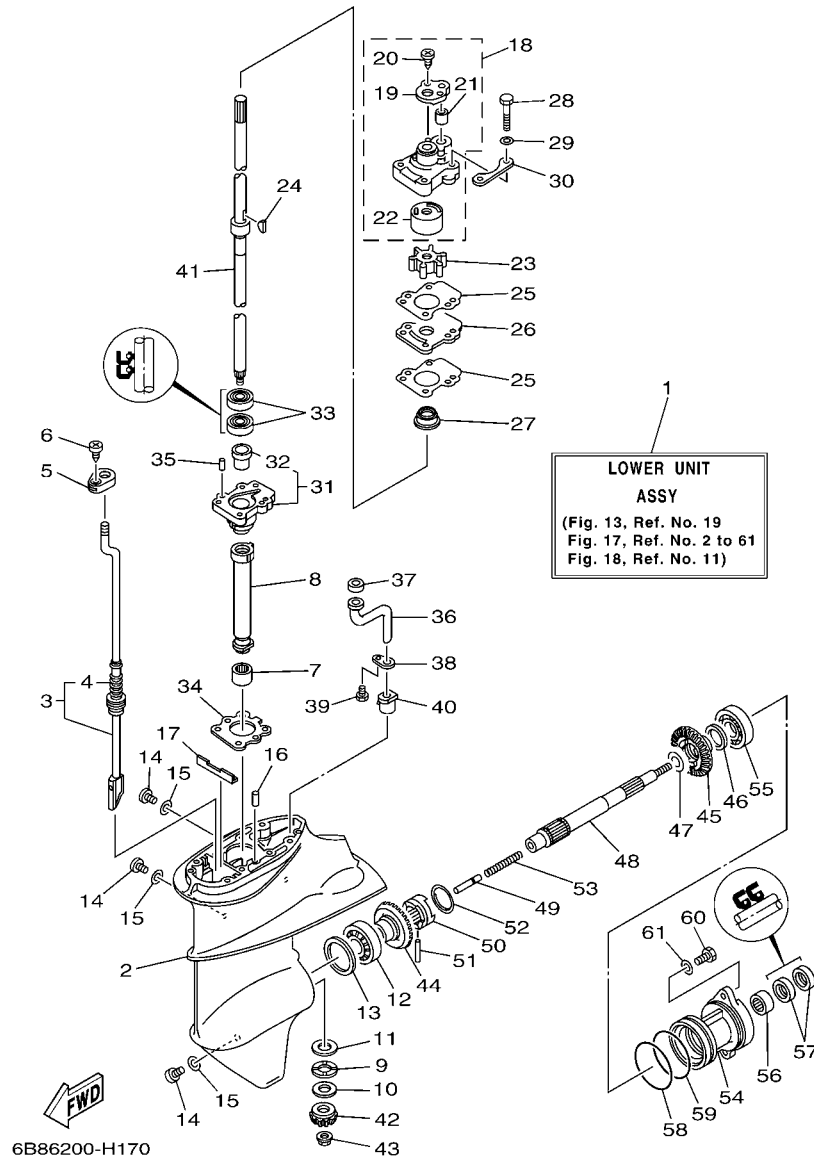

FIG. 16 UPPER CASING

REF. NO.	PART NO.	DESCRIPTION	6B76	6B96	6B86	6C06	REMARKS
1	6B4-41137-00-5B	GUIDE, EXHAUST	1	1	1	1	
2	93606-12019	PIN, DOWEL	2	2	2	2	
3	682-45113-A2	GASKET, UPPER CASING	1	1	1	1	
4	90119-06MA4	BOLT, WITH WASHER	2	2	2	2	
5	93606-12019	PIN, DOWEL	2	2	2	2	
6	682-45111-15-4D	CASING, UPPER	1	1	1	1	L(22.4")
7	97575-08550	BOLT, WITH WASHER	6	6	6	6	
8	6B4-41131-00-5B	MANIFOLD, EXT. 1	1	1	1	1	
9	682-41133-A0	GASKET, EXHAUST MANIFOLD 1	1	1	1	1	
10	97095-06020	BOLT	6	6	6	6	
11	92995-06600	WASHER	6	6	6	6	
12	682-45126-01-5B	PLATE, SEAL DAMPER	1	1	1	1	
13	682-45127-00	SEAL	1	1	1	1	
14	6B4-41116-00-5B	PROTECTOR	1	1	1	1	L(22.4")
15	90105-06M01	BOLT, FLANGE	4	4	4	4	
16	90157-06M06	SCREW, PAN HEAD	1	1	1	1	
17	6E7-82127-00	WIRE, LEAD 2	1	1	1	1	
18	6B4-45318-00	BUSHING, DRIVE SHAFT	1	1	1	1	L(22.4")
19	93420-30042	CIRCLIP	1	1	1	1	L(22.4")
20	682-44532-00	STOPPER, UPPER MOUNT	1	1	1	1	



6B86200-H170

FIG. 17 LOWER CASING & DRIVE 1

REF. NO.	PART NO.	DESCRIPTION	6B76	6B96	6B86	6C06	REMARKS
1	6B4-45300-11-4D	LOWER UNIT ASSY	1	1	1	1	L(22.4")
2	6E8-45311-01-4D	CASING, LOWER	1	1	1	1	
3	6B4-44150-10	SHIFT CAM ASSY	1	1	1	1	L(22.4")
4	6B4-44147-00	.BOOT, SHIFT ROD	1	1	1	1	
5	682-44176-00	BRACKET	1	1	1	1	
6	97780-50110	SCREW, TAPPING	1	1	1	1	
7	93315-314V8	BEARING	1	1	1	1	
8	6E7-45536-00	SLEEVE, DRIVE SHAFT	1	1	1	1	
9	90209-14011	WASHER	1	1	1	1	
10	6E8-45587-10	SHIM (T:1.13MM)	1	1	1	1	UR
	6E8-45587-30	SHIM (T:1.20MM)	1	1	1	1	UR
11	90201-15017	WASHER, PLATE	1	1	1	1	
12	93332-00005	BEARING	1	1	1	1	
13	664-45567-01	SHIM (T:0.10MM)	1	1	1	1	UR
	664-45567-10	SHIM (T:0.12MM)	1	1	1	1	UR
	664-45567-20	SHIM (T:0.15MM)	1	1	1	1	UR
	664-45567-30	SHIM (T:0.18MM)	1	1	1	1	UR
	664-45567-40	SHIM (T:0.30MM)	1	1	1	1	UR
	664-45567-50	SHIM (T:0.40MM)	1	1	1	1	UR
	664-45567-60	SHIM (T:0.50MM)	1	1	1	1	UR
14	90340-08002	PLUG, STRAIGHT SCREW	3	3	3	3	
15	90430-08020	GASKET	3	3	3	3	
16	93604-08062	PIN, DOWEL	1	1	1	1	
17	682-45376-01	GUIDE, SEAL DAMPER	1	1	1	1	
18	682-44300-40	HOUSING WATER PUMP ASSY	1	1	1	1	FOR CHROMATE
19	682-44312-00	.COVER, WATER PUMP HOUSING	1	1	1	1	
20	97780-40112	.SCREW, OVAL HEAD TAPPING	2	2	2	2	

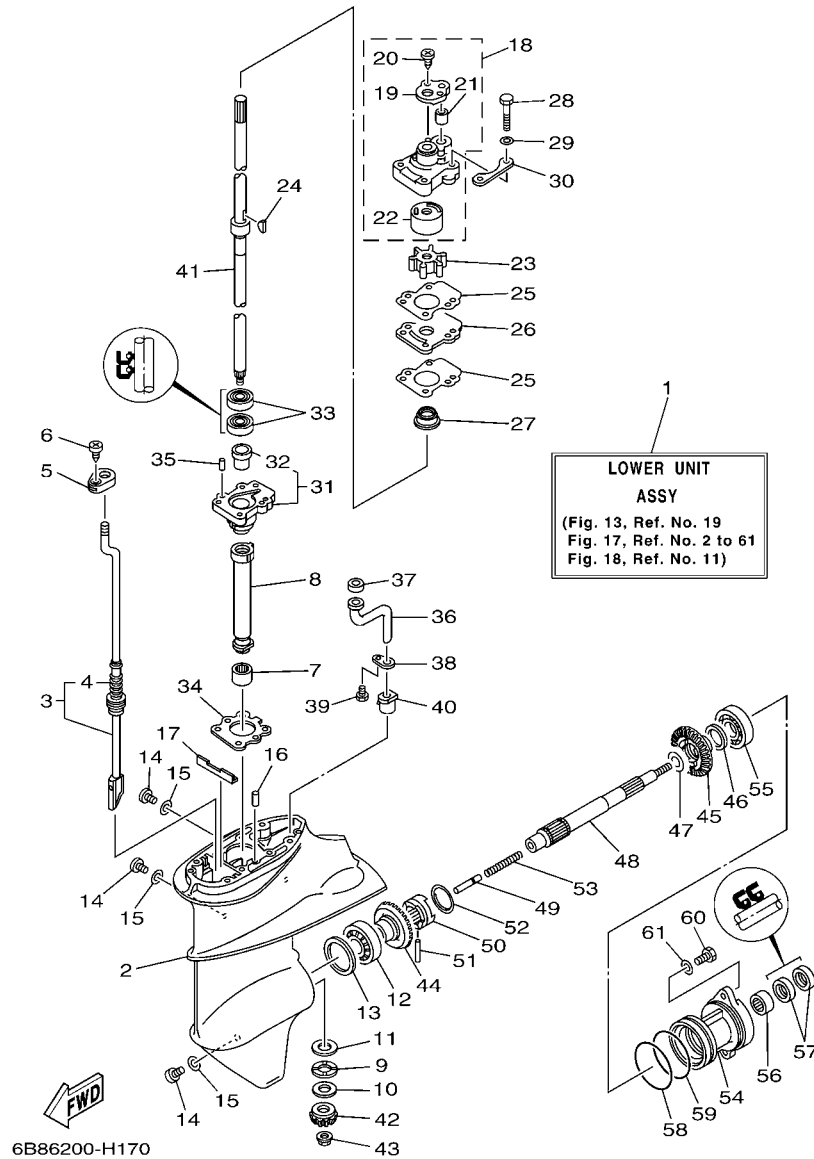

FIG. 17 LOWER CASING & DRIVE 1

REF. NO.	PART NO.	DESCRIPTION	6B76	6B96	6B86	6C06	REMARKS
21	682-44365-00	.DAMPER, WATER SEAL	1	1	1	1	
22	682-44322-41	.INSERT, CARTRIDGE	1	1	1	1	
23	682-44352-03	IMPELLER	1	1	1	1	
24	90280-03005	KEY, WOODRUFF	1	1	1	1	
25	682-44315-A0	GASKET, WATER PUMP	2	2	2	2	
26	682-44323-40	OUTER PLATE, CARTRIDGE	1	1	1	1	FOR CHROMATE
27	682-45344-00	COVER, OIL SEAL	1	1	1	1	
28	97095-06045	BOLT	4	4	4	4	
29	92995-06600	WASHER	4	4	4	4	
30	682-44328-00	PLATE	2	2	2	2	
31	6E7-45331-00-5B	HOUSING, BEARING	1	1	1	1	
32	626-45316-09	.BUSHING, DRIVE SHAFT	1	1	1	1	
33	93101-20001	OIL SEAL	2	2	2	2	
34	683-45315-A0	PACKING, LOWER CASING	1	1	1	1	
35	93606-12019	PIN, DOWEL	2	2	2	2	
36	683-44362-01	TUBE, WATER	1	1	1	1	
37	683-44365-01	DAMPER, WATER SEAL	1	1	1	1	
38	683-44373-00	SET PLATE, WATER TUBE	1	1	1	1	
39	97095-06010	BOLT	1	1	1	1	
40	6E7-44366-00	DAMPER, WATER SEAL	1	1	1	1	
41	6B4-45501-10	DRIVE SHAFT COMP.	1	1	1	1	L(22.4")
42	63V-45551-00	PINION (13T)	1	1	1	1	
43	90179-08M06	NUT	1	1	1	1	
44	6E7-45560-01	GEAR 1 (27T)	1	1	1	1	
45	6E7-45571-00	GEAR 2 (27T)	1	1	1	1	
46	626-45577-00	SHIM (T:0.10MM)	1	1	1	1	UR
	626-45577-10	SHIM (T:0.20MM)	1	1	1	1	UR

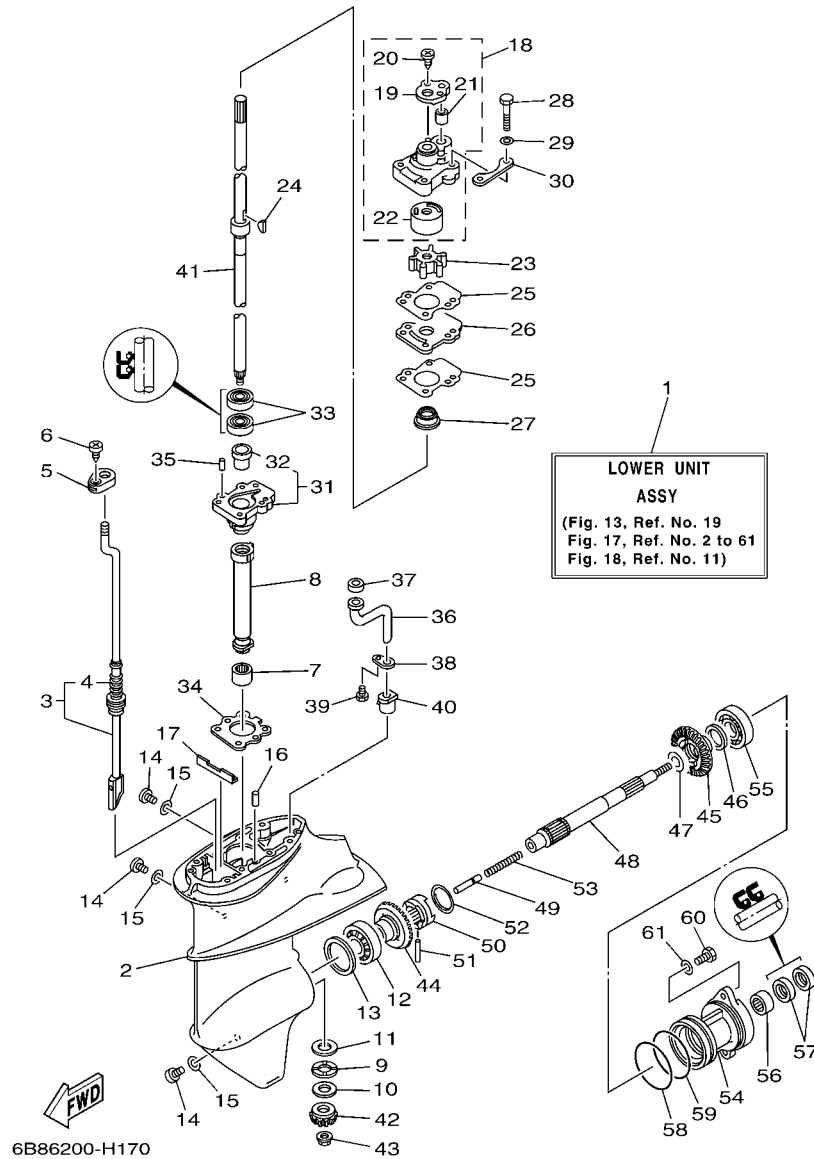

FIG. 17 LOWER CASING & DRIVE 1

REF. NO.	PART NO.	DESCRIPTION	6B76	6B96	6B86	6C06	REMARKS
46	626-45577-20	SHIM (T:0.30MM)	1	1	1	1	UR
	626-45577-30	SHIM (T:0.40MM)	1	1	1	1	UR
	626-45577-40	SHIM (T:0.50MM)	1	1	1	1	UR
47	90201-17682	WASHER, PLATE	1	1	1	1	
48	683-45611-00	SHAFT, PROPELLER	1	1	1	1	
49	650-45635-00	PLUNGER, SHIFT	1	1	1	1	
50	682-45631-00	CLUTCH, DOG	1	1	1	1	
51	90250-05010	PIN, STRAIGHT	1	1	1	1	
52	648-45633-00	RING, CROSS PIN	1	1	1	1	
53	90501-14M06	SPRING, COMPRESSION	1	1	1	1	
54	683-45361-02-4D	CAP, LOWER CASING	1	1	1	1	
55	93306-00501	BEARING	1	1	1	1	
56	93315-317U2	BEARING	1	1	1	1	
57	93101-17001	OIL SEAL	2	2	2	2	
58	93210-57M09	O-RING	1	1	1	1	
59	93210-56M80	O-RING	1	1	1	1	
60	97095-06020	BOLT	2	2	2	2	
61	92995-06600	WASHER	2	2	2	2	



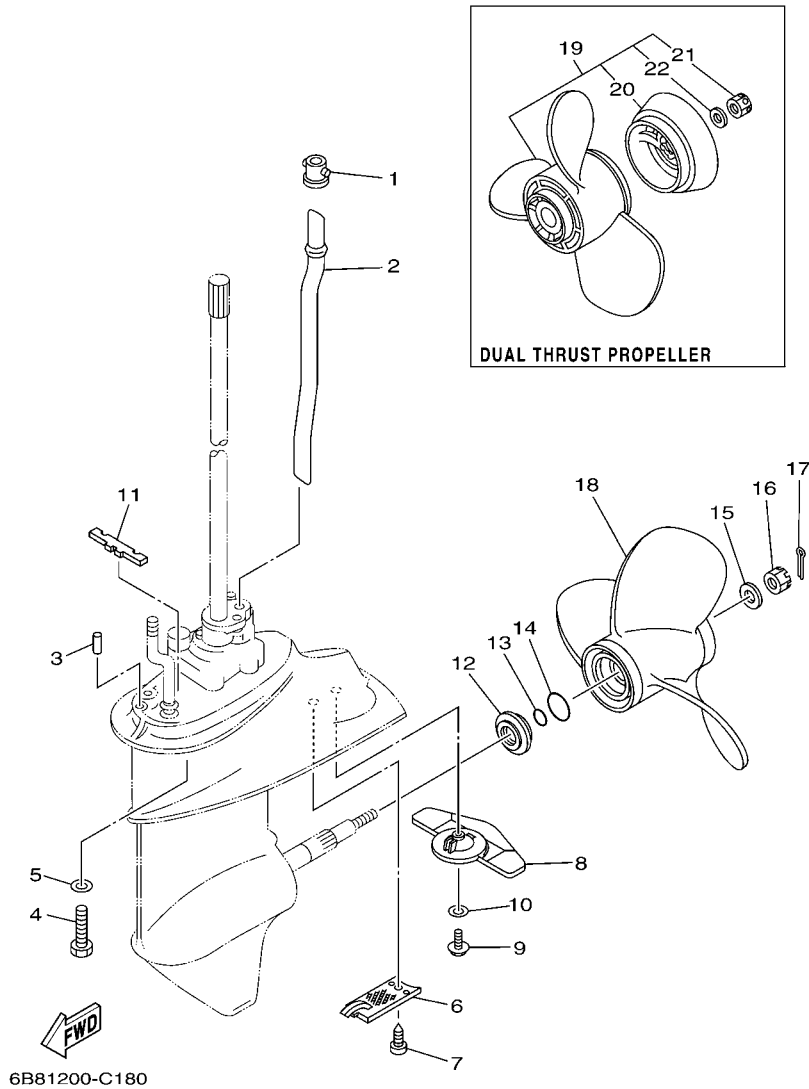
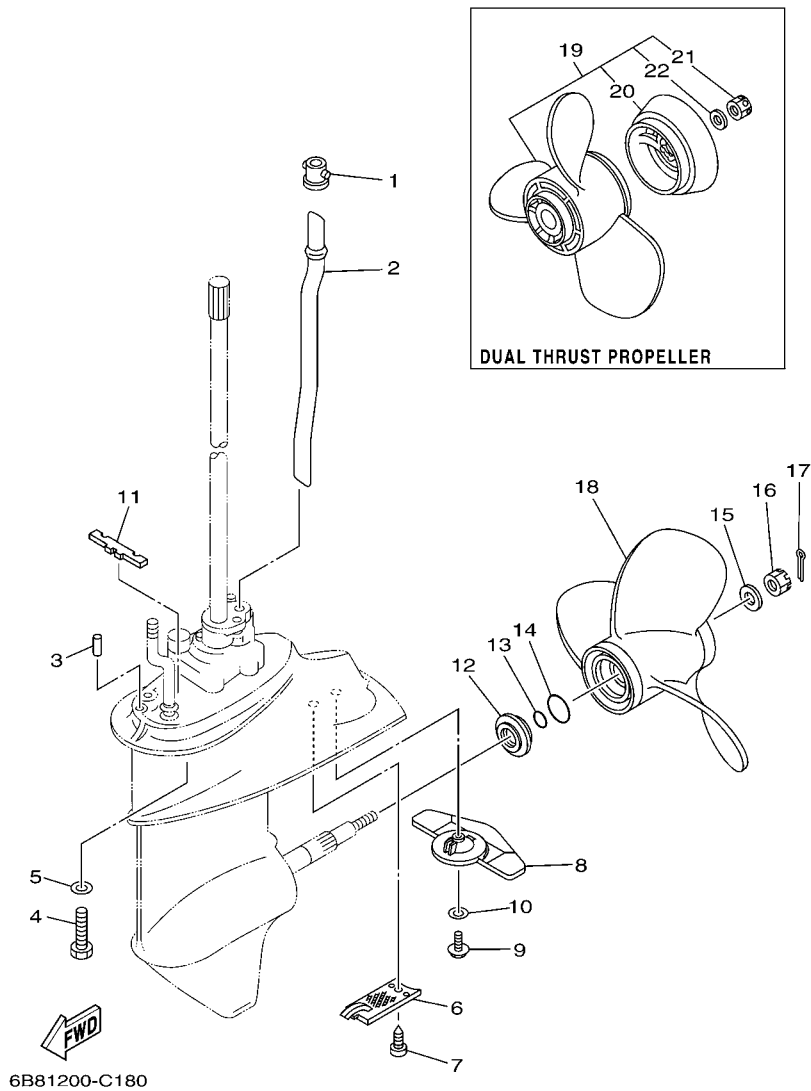

FIG. 18 LOWER CASING & DRIVE 2

REF. NO.	PART NO.	DESCRIPTION	6B76	6B96	6B86	6C06	REMARKS
1	626-44365-01	DAMPER, WATER SEAL	1	1	1	1	
2	6B4-44361-10	TUBE, WATER	1	1	1	1	L(22.4")
3	93606-12019	PIN, DOWEL	2	2	2	2	
4	97075-08035	BOLT	4	4	4	4	
5	92995-08600	WASHER	4	4	4	4	
6	6E7-45214-00	COVER, WATER INLET 1	1	1	1	1	
7	97880-05012	SCREW, PAN HEAD	1	1	1	1	
8	6B4-45251-00	ANODE	1	1	1	1	
9	95895-06020	BOLT, FLANGE	1	1	1	1	
10	92990-06300	WASHER, INTERNAL TOOTH	1	1	1	1	
11	682-45375-01	DAMPER, SEAL	1	1	1	1	
12	6B8-45987-00	SPACER	1	1	1	1	
13	93210-15001	O-RING	1	1	1	1	
14	93210-26003	O-RING	1	1	1	1	
15	90201-10M01	WASHER, PLATE	1	1	1	1	
16	90171-10M01	NUT, CASTLE	1	1	1	1	
17	91490-30020	PIN, COTTER	1	1	1	1	
18	683-45941-00-EL	PROPELLER (3X9-1/4"X12"-J)	1	1	1	1	UR
	683-45943-00-EL	PROPELLER (3X9-1/4"X10-1/2"-J)	1	1	1	1	UR
	683-45947-00-EL	PROPELLER (3X9-1/4"X8"-J)	1	1	1	1	UR
	683-45949-00-EL	PROPELLER (3X9-1/2"X6-1/2"-J)	1	1	1	1	UR
	683-45952-00-EL	PROPELLER (3X9-1/4"X9-3/4"-J)	1	1	1	1	UR
	63V-45945-10-EL	PROPELLER (3X9-1/4"X9"-J1)	1	1	1	1	UR
	63V-45947-00-EL	PROPELLER (3X9-1/4"X8"-J)	1	1	1	1	UR
	63V-45952-10-EL	PROPELLER (3X9-1/4"X10"-J1)	1	1	1	1	UR
19	683-W4591-02-EL	PROPELLER (3X9-3/4"X8"-J)	1	1	1	1	UR
	683-W4592-02-EL	PROPELLER (3X9-3/4"X6-1/2"-J)	1	1	1	1	UR



**FIG. 18 LOWER CASING & DRIVE 2**

REF. NO.	PART NO.	DESCRIPTION	6B76	6B96	6B86	6C06	REMARKS
20	6E7-45986-00	.RING, DEFLECTOR	1	1	1	1	
21	90171-10M07	.NUT, CASTLE	1	1	1	1	
22	90201-10M02	.WASHER, PLATE	1	1	1	1	
-----							
-----							
-----							
-----							
-----							
-----							
-----							
-----							
-----							

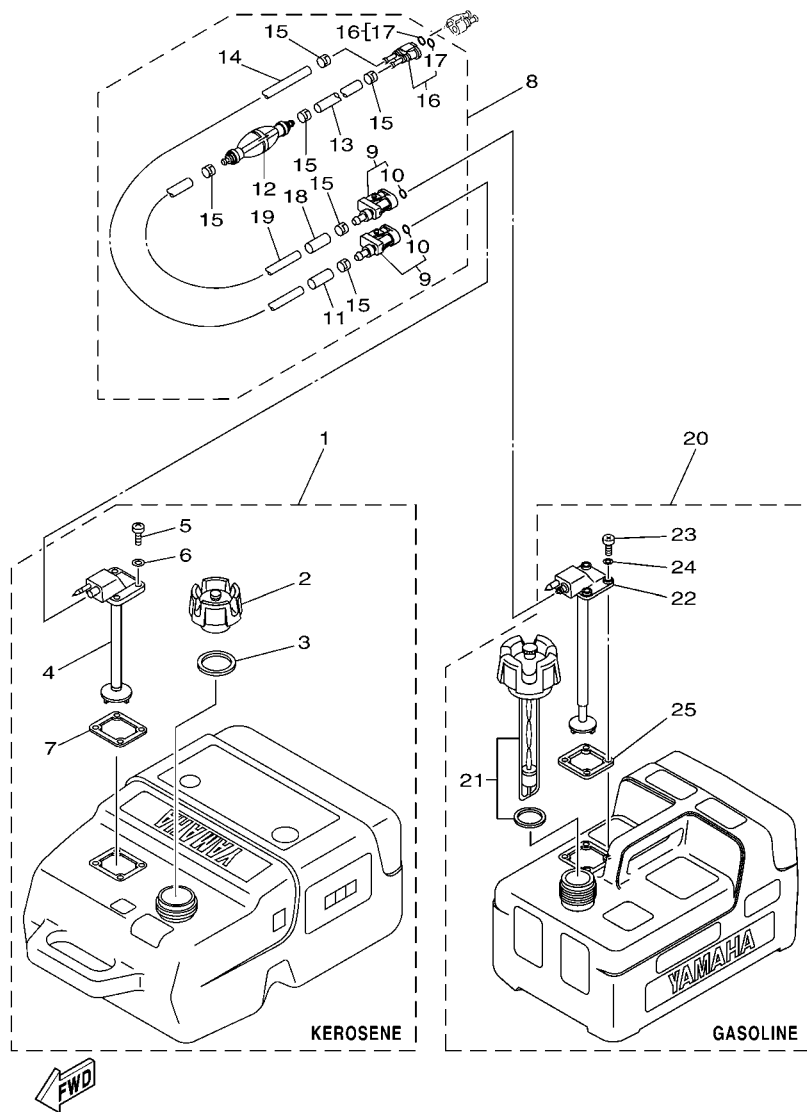

69T5200-D190

FIG. 19 FUEL TANK

REF. NO.	PART NO.	DESCRIPTION	6B76	6B96	6B86	6C06	REMARKS
1	6YK-24201-21	FUEL TANK ASSY (25L,KEROSENE)	1		1		AP KEROSENE
2	6YK-24610-10	.CAP ASSY	1		1		WITHOUT INDICATOR
3	6YL-24641-00	.GASKET, CAP 1	1		1		
4	6YK-24260-01	.FUEL METER ASSY	1		1		
5	90157-05M16	.SCREW, PAN HEAD	4		4		
6	6YL-24329-00	.SEAL	4		4		
7	6YL-24268-01	.GASKET, FUEL METER	1		1		
8	6YK-24306-04	FUEL PIPE COMP. 1	1		1		AP
9	6Y1-24305-06	.FUEL PIPE JOINT COMP. 2	2		2		
10	93210-08287	..O-RING	1		1		
11	6Y1-24397-10	.COLLAR (KEROSENE)	1		1		
12	61J-24360-00	.PRIMER PUMP ASSY	1		1		
13	90445-11M05	.HOSE (L850)	1		1		
14	90445-11M81	.HOSE (L3000)	1		1		
15	650-24351-01	.BAND 1	6		6		
16	680-24305-01	.FUEL PIPE JOINT COMP. 2	1		1		
17	93210-08287	..O-RING	2		2		
18	6Y1-24397-00	.COLLAR (GASOLINE)	1		1		
19	90445-11M06	.HOSE (L2050)	1		1		
20	6YL-24201-05	FUEL TANK ASSY (12L)	1		1		AP GASOLINE
21	6YL-24610-01	.CAP ASSY	1		1		
22	6YL-24260-01	.FUEL METER ASSY	1		1		
23	90157-05M16	.SCREW, PAN HEAD	4		4		
24	6YL-24329-00	.SEAL	4		4		
25	6YL-24268-01	.GASKET, FUEL METER	1		1		

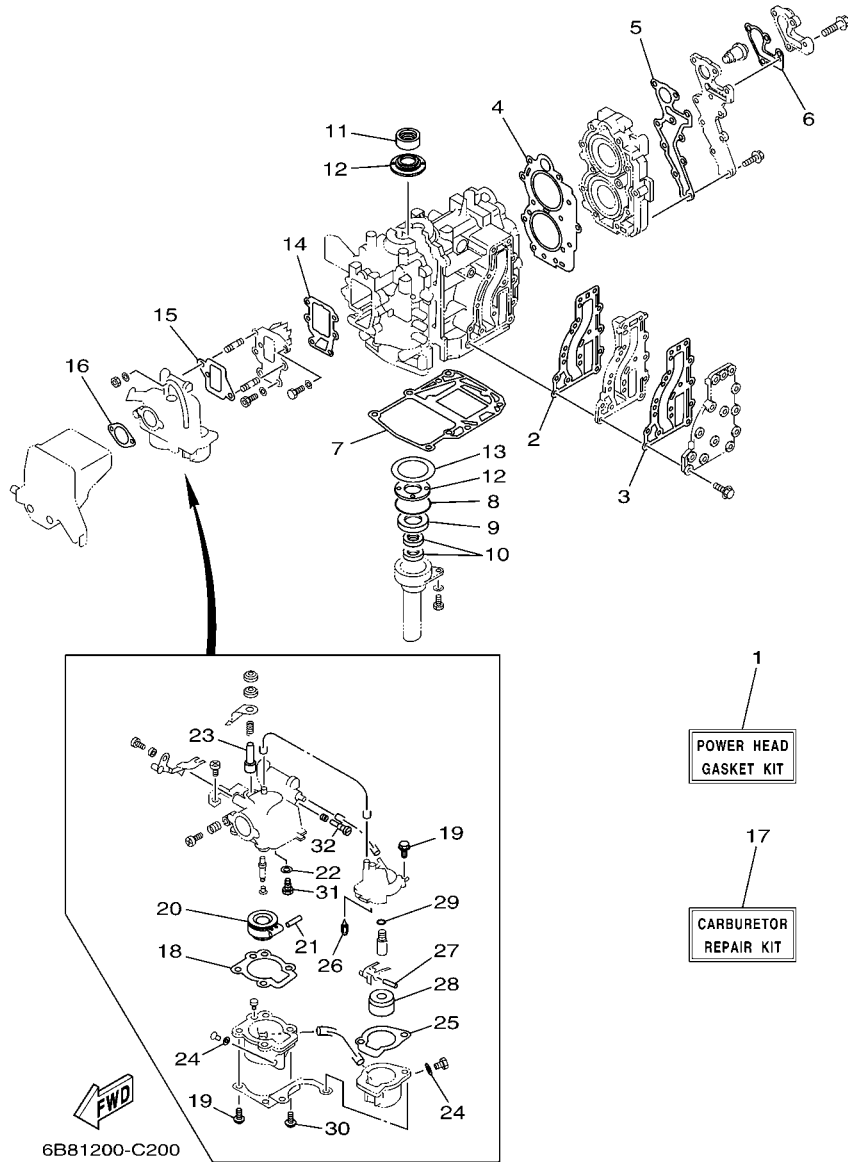
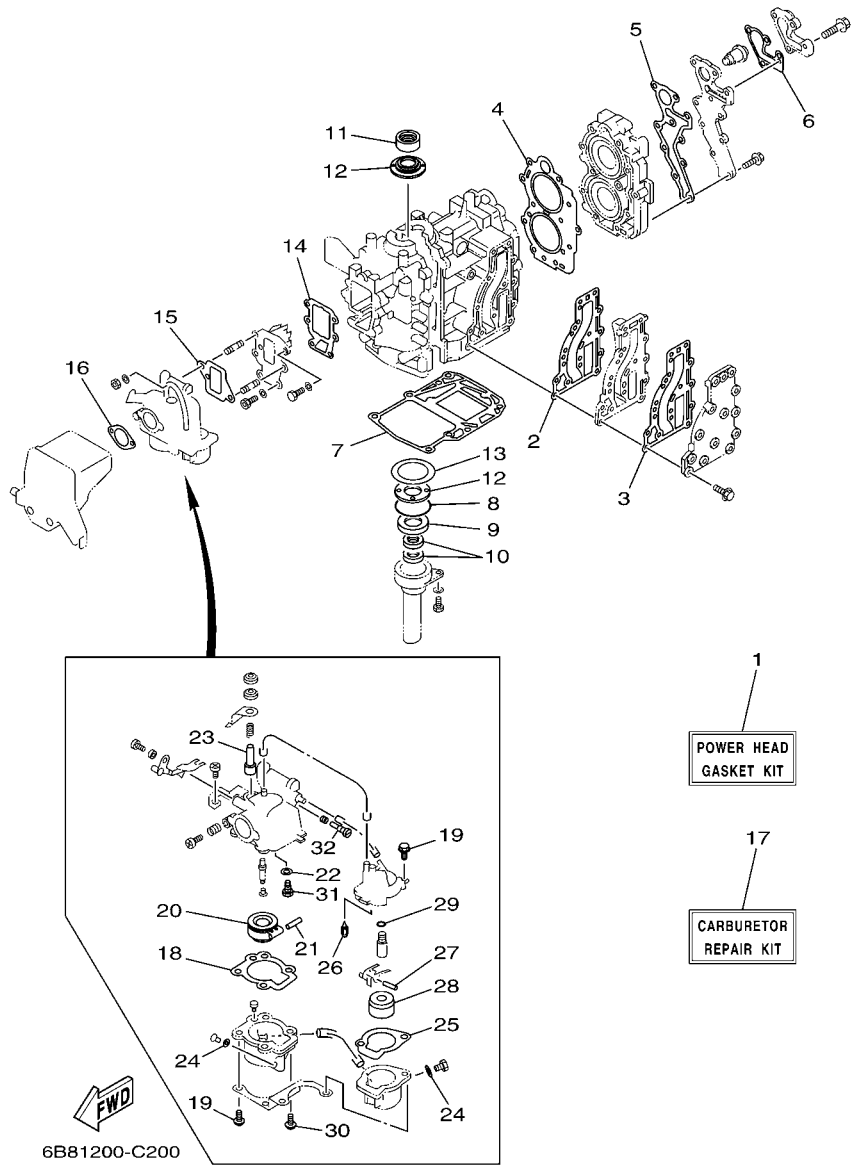

FIG. 20 REPAIR KIT 1

REF. NO.	PART NO.	DESCRIPTION	6B76	6B96	6B86	6C06	REMARKS
1	6B8-W0001-00	POWER HEAD GASKET KIT	1	1	1	1	
2	6B4-41112-A0	.GASKET, EXHAUST INNER COVER	1	1	1	1	
3	63V-41112-A0	.GASKET, EXHAUST INNER COVER	1	1	1	1	
4	63V-11181-A1	.GASKET, CYLINDER HEAD 1	1	1	1	1	
5	6B4-11193-A1	.GASKET, HEAD COVER 1	1	1	1	1	
6	682-12414-A1	.GASKET, COVER	1	1	1	1	
7	6B4-11351-A0	.GASKET, CYLINDER	1	1	1	1	
8	93210-46MH8	.O-RING	1	1	1	1	
9	93102-25010	.OIL SEAL	1	1	1	1	
10	93101-13M27	.OIL SEAL	2	2	2	2	
11	93110-23M00	.OIL SEAL	1	1	1	1	
12	63V-11445-00	.SPACER	2	2	2	2	
13	90201-46M29	.WASHER, PLATE	1	1	1	1	
14	682-13621-A1	.GASKET, VALVE SEAT	1	1	1	1	
15	677-14198-A1	.GASKET	1	1	1	1	
16	6B8-14483-00	.GASKET	1	1	1	1	
17	6B8-W0093-00	CARBURETOR REPAIR KIT	1	1	1	1	
18	650-14384-00	.GASKET, FLOAT CHAMBER	1	1	1	1	
19	97980-04115	.SCREW, WITH WASHER	4	4	4	4	
20	6B8-14385-00	.FLOAT	1	1	1	1	
21	626-14386-10	.PIN, FLOAT	1	1	1	1	
22	626-14398-00	.GASKET	1	1	1	1	
23	626-14371-00	.PLUNGER, STARTER	1	1	1	1	
24	6L2-14398-00	.GASKET	2	2	2	2	
25	652-14384-00	.GASKET, FLOAT CHAMBER	1	1	1	1	
26	6F5-14392-00	.VALVE, NEEDLE	1	1	1	1	
27	6M7-14386-00	.PIN, FLOAT	1	1	1	1	

FIG. 20 REPAIR KIT 1

REF. NO.	PART NO.	DESCRIPTION	6B76	6B96	6B86	6C06	REMARKS
28	652-14385-00	.FLOAT	1	1	1	1	
29	652-14147-00	.O-RING	1	1	1	1	
30	97980-04112	.SCREW, WITH WASHER	2	2	2	2	
31	677-14390-12	.NEEDLE VALVE ASSY	1	1	1	1	
32	647-14323-00	.SCREW, AIR ADJUSTING	1	1	1	1	
-----							
-----							
-----							
-----							
-----							
-----							
-----							
-----							
-----							
-----							



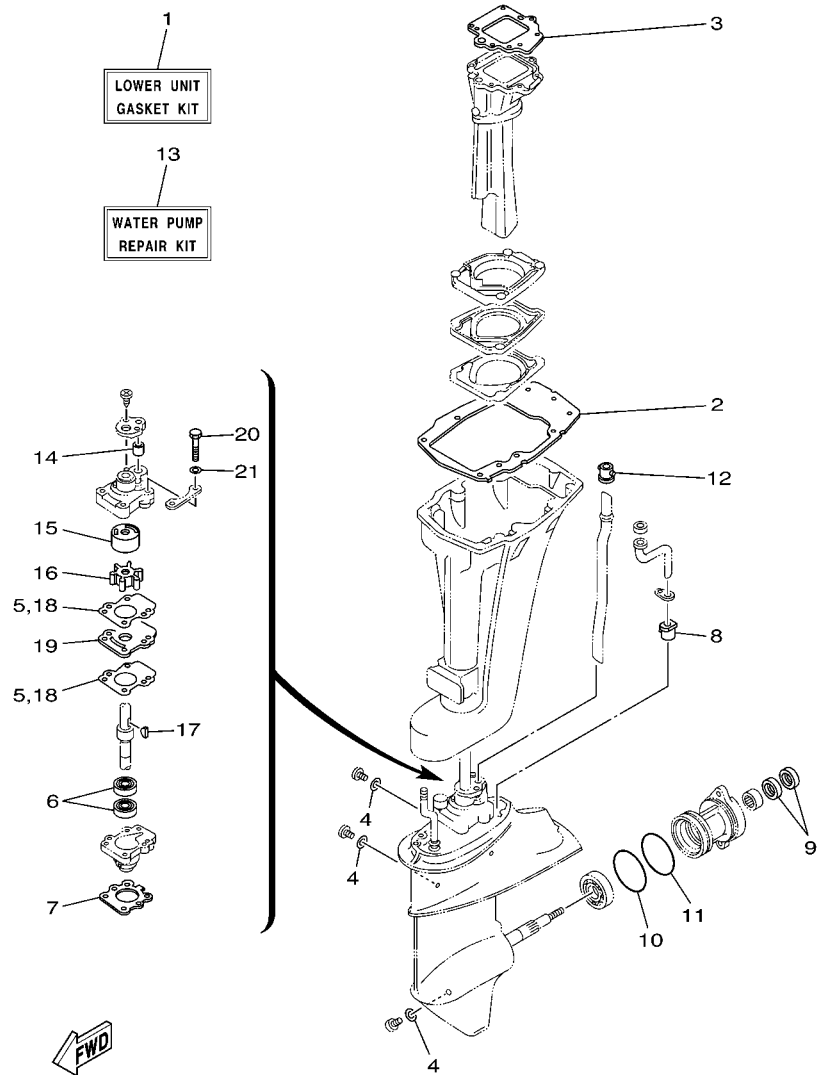

6B31200-3200

FIG. 21 REPAIR KIT 2

REF. NO.	PART NO.	DESCRIPTION	6B76	6B96	6B86	6C06	REMARKS
1	6B4-W0001-20	LOWER UNIT GASKET KIT	1	1	1	1	
2	682-45113-A2	.GASKET, UPPER CASING	1	1	1	1	
3	682-41133-A0	.GASKET, EXHAUST MANIFOLD 1	1	1	1	1	
4	90430-08020	.GASKET	3	3	3	3	
5	682-44315-A0	.GASKET, WATER PUMP	2	2	2	2	
6	93101-20001	.OIL SEAL	2	2	2	2	
7	683-45315-A0	.PACKING, LOWER CASING	1	1	1	1	
8	6E7-44366-00	.DAMPER, WATER SEAL	1	1	1	1	
9	93101-17001	.OIL SEAL	2	2	2	2	
10	93210-57M09	.O-RING	1	1	1	1	
11	93210-56M80	.O-RING	1	1	1	1	
12	626-44365-01	.DAMPER, WATER SEAL	1	1	1	1	
13	6B4-W0078-0A	WATER PUMP REPAIR KIT	1	1	1	1	
14	682-44365-00	.DAMPER, WATER SEAL	1	1	1	1	
15	682-44322-41	.INSERT, CARTRIDGE	1	1	1	1	
16	682-44352-03	.IMPELLER	1	1	1	1	
17	90280-03005	.KEY, WOODRUFF	1	1	1	1	
18	682-44315-A0	.GASKET, WATER PUMP	2	2	2	2	
19	682-44323-40	.OUTER PLATE, CARTRIDGE	1	1	1	1	
20	97095-06045	.BOLT	4	4	4	4	
21	92995-06600	.WASHER	4	4	4	4	

NUMERICAL INDEX

PART NO.	REF. NO.	PART NO.	REF. NO.	PART NO.	REF. NO.	PART NO.	REF. NO.	PART NO.	REF. NO.	PART NO.	REF. NO.
6B8-11111-00-1S	2 - 19	647-14323-00	5 - 6	6L2-14398-00	5 - 26	6Y3-24306-04	7 - 1	63V-41113-00-1S	2 - 15	682-43112-05-4D	14 - 2
63V-11181-A1	2 - 20		20 - 32		20 - 24	6YK-24306-04	19 - 8	6B4-41116-00-5B	16 - 14	6B4-43113-00	14 - 12
	20 - 4	6A0-14325-00	6 - 28	6B8-14440-00	4 - 9	6B8-24311-00	6 - 41	6B4-41131-00-5B	16 - 8	648-43114-01	14 - 8
6B4-11191-00-1S	2 - 22	650-14327-01	5 - 23	6B8-14483-00	4 - 11	6J8-24311-00	8 - 27	682-41133-A0	16 - 9	6E7-43116-00	14 - 7
6B4-11193-A1	2 - 23	626-14333-00	5 - 3		20 - 16	6B8-24312-00	6 - 42		21 - 3	663-43118-01-4D	14 - 5
	20 - 5	626-14335-00	5 - 16	624-14485-00	2 - 3	61A-24314-00	6 - 39	6B4-41137-00-5B	16 - 1	66T-43144-00	11 - 14
682-11325-00	2 - 8	6M7-14341-00	5 - 4	6H1-14485-00	2 - 5	688-24314-00	6 - 40	63V-41211-00	13 - 8	689-43160-00	14 - 18
6B4-11351-A0	2 - 30	648-14342-23	5 - 20	650-14485-03	2 - 4	6A4-24329-00	6 - 13	6M7-41252-00	4 - 15	689-43165-00	14 - 19
	20 - 7	648-14343-46	5 - 5	63V-14497-02	13 - 1	6YL-24329-00	19 - 6	6J8-41262-00	13 - 9	6B4-43181-00	14 - 43
676-11372-00	2 - 16	648-14343-51	5 - 5	6B8-15100-00-1S	2 - 2		19 - 24		13 - 29	682-43311-06-4D	14 - 22
6B4-11400-00	3 - 7	648-14344-25	5 - 21	6B4-15396-00-94	3 - 1	650-24351-01	7 - 5	6B8-41271-00	4 - 12	682-43318-01	14 - 52
63V-11412-00	3 - 8	6C0-14344-40	5 - 21	6B4-15663-00	8 - 29		19 - 15	6B4-41273-00	4 - 13		14 - 54
63V-11422-00	3 - 9	65G-14346-00	5 - 36	63V-15705-01	8 - 9	61J-24360-00	7 - 3	6B4-41274-00	4 - 14	676-43373-00	14 - 26
63V-11432-00	3 - 10	65G-14348-00	5 - 41	6B4-15710-00	8 - 1		19 - 12	6B4-41283-00	13 - 6	682-43611-01	14 - 37
63V-11442-00	3 - 11		5 - 41	6B4-15711-00	8 - 2	6Y1-24397-00	19 - 18	6B4-41638-00	13 - 10	682-43614-01	14 - 35
63V-11445-00	3 - 28	6A4-14348-00	5 - 34	63V-15713-00	8 - 7	6Y1-24397-10	19 - 11	6B4-41662-00	13 - 21	682-43615-02	14 - 36
	20 - 12	6M7-14348-00	5 - 35	63V-15714-00	8 - 5	6A4-24410-06	6 - 14	6B4-42111-00-4D	12 - 1	682-43616-00	14 - 30
63V-11515-02	3 - 14	65G-14348-11	5 - 42	63V-15716-00	8 - 8	648-24411-00	6 - 24	6B4-42119-00	12 - 15	682-43617-00	14 - 34
682-11610-01	3 - 22	650-14349-00	5 - 24	63V-15726-00	8 - 19	663-24411-00	6 - 30	6B4-42125-00	12 - 11	6B4-43627-00	14 - 44
682-11610-11	3 - 22	6B8-14349-00	5 - 44	63V-15734-00	8 - 17	6A0-24412-02	6 - 35	6B4-42126-00	12 - 12	6B4-43631-00	14 - 28
682-11610-21	3 - 22	652-14353-34	5 - 37	63V-15741-00	8 - 6	6A0-24413-00	6 - 32	6A0-42131-00-4D	12 - 6	682-43641-01	14 - 31
6E7-11631-00-97	3 - 21	626-14371-00	5 - 15	63V-15744-00	8 - 12	652-24415-01	6 - 18	6F5-42137-00	12 - 16	682-43643-00	14 - 55
634-11633-00	3 - 23		20 - 23	6B4-15746-00	13 - 23	6A0-24421-01	6 - 27	6B4-42138-00	12 - 23	682-43659-01	14 - 39
6E7-11635-00	3 - 21	626-14373-00	5 - 17	6L2-15747-00	13 - 28	648-24423-00	6 - 26	6B1-42177-00	12 - 18	6B4-43681-00	14 - 53
6E7-11636-00	3 - 21	626-14374-00	5 - 18	63V-15748-00	8 - 16	648-24424-00	6 - 25	6B4-42511-00-4D	15 - 2	6B4-44111-00-4D	13 - 11
6K4-11651-00	3 - 16	6M7-14376-00	5 - 22	6G1-15755-00	8 - 20	650-24431-A0	6 - 37	682-42521-00-94	15 - 6	6B4-44116-00	13 - 16
682-11681-00	3 - 15	626-14378-00	5 - 19	6B4-15758-00-4D	8 - 22	652-24432-00	6 - 22	648-42528-00	15 - 1	6B4-44121-00	13 - 12
6F5-12411-03	2 - 26	680-14381-00	5 - 8	6B4-15761-00	1 - 15	648-24434-01	6 - 23	682-42537-00	15 - 8	6B4-44125-00	13 - 14
6E5-12412-00	2 - 27	680-14381-10	5 - 8	6B4-15762-00	8 - 23	648-24435-02	6 - 31	6B7-42610-00-4D	1 - 1	6B4-44143-00	13 - 18
682-12413-00-1S	2 - 25	650-14384-00	5 - 9	63V-15764-00	8 - 3	62C-24461-00	6 - 16	6B8-42610-00-4D	1 - 1	61N-44146-00	13 - 20
682-12414-A1	2 - 28		20 - 18	68T-15764-00	8 - 4	652-24461-00	6 - 15	6B4-42613-00-4D	1 - 7	6B4-44147-00	17 - 4
	20 - 6	652-14384-00	5 - 29	63V-15767-01	8 - 10	6A4-24471-00	6 - 21	6B4-42615-00	1 - 2	6B4-44150-10	17 - 3
6B8-13437-00	1 - 14		20 - 25	63V-15768-00	8 - 13	652-24471-10	6 - 17	6B4-42628-00	1 - 8	682-44176-00	17 - 5
6B8-13610-00	4 - 1	652-14385-00	5 - 33	6B4-15770-00	13 - 30	61N-24521-00	6 - 6	6B4-42646-00	1 - 16	682-44300-40	17 - 18
682-13621-A1	4 - 3		20 - 28	6G1-15779-00	8 - 21	61N-24560-00	6 - 4	6B4-42647-00	1 - 5	682-44312-00	17 - 19
	20 - 14	6B8-14385-00	5 - 11	68T-15784-00	8 - 11	61N-24563-00	6 - 5	6B4-42651-00	1 - 3	682-44315-A0	17 - 25
652-14147-00	5 - 38		20 - 20	6A0-15789-00	8 - 28	6B8-24566-00	6 - 11	677-42677-J0	1 - 12		21 - 5
	20 - 29	6M7-14386-00	5 - 32	63V-15794-00	8 - 15	6YL-24610-01	19 - 21	6B7-42678-K0	1 - 13		21 - 18
680-14181-00	5 - 28		20 - 27	6YL-24201-05	19 - 20	6YK-24610-10	19 - 2	6M7-42678-K0	1 - 13	682-44322-41	17 - 22
65G-14182-00	5 - 27	626-14386-10	5 - 12	6YK-24201-21	19 - 1	6YL-24641-00	19 - 3	6B4-42711-00-4D	11 - 1		21 - 15
65G-14182-20	5 - 27		20 - 21	6YK-24260-01	19 - 4	6B4-26301-00	12 - 24	6B4-42716-00	11 - 12	682-44323-40	17 - 26
677-14198-A1	4 - 8	652-14387-40	5 - 31	6YL-24260-01	19 - 22	61N-26326-00	11 - 2	6B4-42727-00	11 - 3		21 - 19
	20 - 15	677-14390-12	5 - 13	6YL-24268-01	19 - 7	63V-28100-A0	6 - 45	6E7-42791-00	11 - 20	682-44328-00	17 - 30
	5 - 7		20 - 31		19 - 25	63V-41111-00-1S	2 - 12	6AH-42794-40	11 - 21	682-44352-03	17 - 23
646-14212-01	5 - 7		5 - 30	680-24304-01	6 - 1	63V-41112-A0	2 - 14	6B4-42815-00-4D	11 - 4		21 - 16
65G-14261-00	5 - 43	6F5-14392-00	5 - 30	680-24305-01	7 - 6		20 - 3	6B4-42816-00	11 - 5	6B4-44361-10	18 - 2
6B8-14301-00	5 - 1		20 - 26		19 - 16	6B4-41112-A0	2 - 13	6B9-42821-00	15 - 21	683-44362-01	17 - 36
6C0-14301-01	5 - 1	626-14398-00	5 - 14		19 - 9		20 - 2	682-43111-05-4D	14 - 1	682-44365-00	17 - 21
650-14321-01	5 - 2		20 - 22	6Y1-24305-06	19 - 9						

NUMERICAL INDEX

PART NO.	REF. NO.	PART NO.	REF. NO.	PART NO.	REF. NO.	PART NO.	REF. NO.	PART NO.	REF. NO.	PART NO.	REF. NO.
682-44365-00	21 - 14	626-45577-10	17 - 46	683-W4592-02-EL	18 - 19	90206-10M24	14 - 49	90465-11M10	10 - 8	92995-06600	17 - 29
626-44365-01	18 - 1	626-45577-20	17 - 46	90101-06128	4 - 6	90206-12052	11 - 8	90465-11M52	15 - 21		17 - 61
	21 - 12	626-45577-30	17 - 46	90101-06M29	14 - 15	90206-28001	12 - 5	90467-06016	2 - 7		21 - 21
683-44365-01	17 - 37	626-45577-40	17 - 46	90101-08M30	15 - 15	90209-14011	17 - 9	90467-08004	6 - 9	92995-08600	12 - 8
6E7-44366-00	17 - 40	6E8-45587-10	17 - 10	90101-12013	14 - 9	90209-20M23	3 - 18	90467-09M03	6 - 10		12 - 10
	21 - 8	6E8-45587-30	17 - 10	90105-06M01	16 - 15	90209-52M01	15 - 7	90468-10004	4 - 20		18 - 5
683-44373-00	17 - 38	683-45611-00	17 - 48	90105-07M05	2 - 21	90243-04007	14 - 6	90480-25161	10 - 9	93101-13M27	3 - 4
6H3-44391-01	11 - 13	682-45631-00	17 - 50	90109-06M05	14 - 42	90249-06M23	14 - 32	90501-14M06	17 - 53		20 - 10
682-44514-01-94	15 - 12	648-45633-00	17 - 52	90109-06M80	11 - 15	90249-10003	14 - 45	90501-18M00	14 - 24	93101-17001	17 - 57
682-44521-01	15 - 22	650-45635-00	17 - 49		13 - 17	90250-05010	17 - 51	90501-23215	12 - 21		21 - 9
682-44522-01	15 - 20	683-45941-00-EL	18 - 18	90109-06M81	13 - 22	90266-04005	1 - 6	90502-10M07	14 - 21	93101-20001	17 - 33
682-44522-10	15 - 20	683-45943-00-EL	18 - 18	90116-06130	4 - 22	90266-04M00	1 - 4	90506-12002	14 - 46		21 - 6
682-44532-00	16 - 20	63V-45945-10-EL	18 - 18	90119-06023	2 - 24	90269-02M09	12 - 17	90506-18009	11 - 16	93102-25010	3 - 3
682-44551-02-4D	15 - 23	63V-45947-00-EL	18 - 18	90119-06M40	9 - 14	90280-03005	17 - 24	90506-26M01	14 - 41		20 - 9
682-44552-02-4D	15 - 24	683-45947-00-EL	18 - 18	90119-06M82	8 - 26		21 - 17	90508-08M39	13 - 25	93110-23M00	3 - 27
6B4-44555-30	15 - 29	683-45949-00-EL	18 - 18	90119-06MA3	2 - 29	90280-05013	9 - 9	90508-14018	14 - 29		20 - 11
682-44557-00	15 - 28	683-45952-00-EL	18 - 18	90119-06MA4	2 - 18	90340-08002	17 - 14	90508-20M38	13 - 7	93210-08287	7 - 7
682-45111-15-4D	16 - 6	63V-45952-10-EL	18 - 18		16 - 4	90381-12001	14 - 11	91490-16010	12 - 14		19 - 10
682-45113-A2	16 - 3	6E7-45986-00	18 - 20	90119-08M07	2 - 11	90381-20001	12 - 3	91490-16018	8 - 18		19 - 17
	21 - 2	6B8-45987-00	18 - 12	90119-08M45	15 - 25	90381-35001	12 - 2	91490-30020	18 - 17	93210-15001	18 - 13
682-45126-01-5B	16 - 12	6AH-81994-40	8 - 31	90149-05M13	12 - 19	90386-08032	12 - 22	91609-20008	3 - 19	93210-26003	18 - 14
682-45127-00	16 - 13	6AH-81995-40	8 - 30	90157-05M16	19 - 5	90386-12M45	11 - 6	91690-30008	14 - 20	93210-32738	6 - 7
6E7-45214-00	18 - 6	703-82119-00	9 - 15		19 - 23	90386-12MA2	11 - 7	92903-06100	4 - 7	93210-40M10	15 - 10
6B4-45251-00	18 - 8	6E7-82127-00	16 - 17	90157-06M06	16 - 16	90386-40M08	15 - 11	92990-04500	6 - 20	93210-46MH8	3 - 2
6B4-45300-11-4D	17 - 1	6E5-82148-00	14 - 3	90159-05007	4 - 10	90386-40M09	15 - 9	92990-05100	6 - 34		20 - 8
6E8-45311-01-4D	17 - 2	6B4-82316-00	10 - 14	90164-05M00	4 - 17	90387-06M06	13 - 24	92990-06300	18 - 10	93210-56M80	17 - 59
683-45315-A0	17 - 34	62E-8231X-00	10 - 7	90170-12066	9 - 10	90387-06M13	14 - 24	92990-06600	14 - 16		21 - 11
	21 - 7	62E-82371-11	10 - 6	90171-10M01	18 - 16	90387-06M20	14 - 38		14 - 48	93210-57M09	17 - 58
626-45316-09	17 - 32	682-82556-00	11 - 18	90171-10M07	18 - 21	90387-06M24	9 - 13		14 - 57		21 - 10
6B4-45318-00	16 - 18	689-82575-04	11 - 17	90179-08M06	17 - 43	90387-06M50	13 - 2	92990-08600	14 - 25	93306-00501	17 - 55
6E7-45331-00-5B	17 - 31	689-8257Y-00	11 - 19	90185-08057	15 - 19	90430-08020	17 - 15	92995-06600	1 - 10	93306-205A1	3 - 12
682-45344-00	17 - 27	6N7-83557-00	10 - 20	90201-05M03	4 - 16		21 - 4		3 - 6	93310-620W5	3 - 17
683-45361-02-4D	17 - 54	6B4-85520-00	9 - 3	90201-08M12	15 - 16	90445-07M08	2 - 6		4 - 5	93315-314V8	17 - 7
682-45375-01	18 - 11	6B4-85530-00	10 - 4	90201-08M13	15 - 17	90445-09104	2 - 17		4 - 19	93315-317U2	17 - 56
682-45376-01	17 - 17	63V-85533-00	9 - 12	90201-10M01	18 - 15		6 - 38		6 - 3	93332-00005	17 - 12
6B4-45501-10	17 - 41	6B8-85540-00	10 - 1	90201-10M02	12 - 20	90445-100E9	6 - 43		8 - 25	93390-00029	3 - 13
6E7-45536-00	17 - 8	6B4-85550-01	9 - 1		18 - 22	90445-11M05	7 - 4		9 - 5	93420-30042	16 - 19
63V-45551-00	17 - 42	6B4-85570-00	10 - 5	90201-12018	14 - 10		19 - 13		9 - 8	93430-04301	5 - 39
6E7-45560-01	17 - 44	6B4-85580-00	9 - 2	90201-12472	9 - 11	90445-11M06	7 - 2		10 - 3	93440-52009	3 - 20
664-45567-01	17 - 13	6B8-W0001-00	20 - 1	90201-14377	3 - 25		19 - 19		10 - 11	93450-15023	3 - 26
664-45567-10	17 - 13	6B4-W0001-20	21 - 1	90201-15017	17 - 11	90445-11M81	7 - 8		10 - 16	93602-14104	3 - 24
664-45567-20	17 - 13	6B8-W0004-00	4 - 2	90201-17682	17 - 47		19 - 14		10 - 19	93604-08062	17 - 16
664-45567-30	17 - 13	6B3-W0070-H0	1 - 11	90201-28013	12 - 4	90462-06008	2 - 31		11 - 11	93606-12019	2 - 10
664-45567-40	17 - 13	6B4-W0070-H0	1 - 11	90201-46M29	3 - 29	90464-08M02	10 - 13		13 - 5		15 - 3
664-45567-50	17 - 13	6B4-W0078-0A	21 - 13		20 - 13	90464-09M21	6 - 44		13 - 27		16 - 2
664-45567-60	17 - 13	6B8-W0090-00-1S	2 - 1	90202-05203	4 - 21	90465-06M90	9 - 6		15 - 5		16 - 5
6E7-45571-00	17 - 45	6B8-W0093-00	20 - 17	90202-10M56	14 - 50		10 - 12		15 - 14		17 - 35
626-45577-00	17 - 46	683-W4591-02-EL	18 - 19	90202-13M02	15 - 18	90465-08M99	10 - 17		16 - 11		18 - 3



NUMERICAL INDEX

PART NO.	REF. NO.	PART NO.	REF. NO.	PART NO.	REF. NO.	PART NO.	REF. NO.	PART NO.	REF. NO.	PART NO.	REF. NO.
93700-06M03	14 - 23	97780-50110	17 - 6								
94702-00217	2 - 32	97880-05012	18 - 7								
95380-03600	6 - 29	97885-06008	14 - 4								
95380-06600	12 - 13	97980-04005	5 - 25								
95380-06700	4 - 18	97980-04112	5 - 40								
	13 - 19		20 - 30								
	14 - 17	97980-04115	5 - 10								
95380-08600	6 - 8		20 - 19								
95380-08700	15 - 27	98503-05028	6 - 33								
95627-06325	4 - 23	98780-04010	6 - 19								
95680-06100	14 - 47	98780-05015	2 - 9								
95780-12300	14 - 13	99080-05600	14 - 33								
95895-06020	18 - 9		14 - 40								
95895-06065	13 - 3	99080-09600	14 - 51								
97013-06012	6 - 12										
97075-08025	14 - 27										
97075-08035	18 - 4										
97095-06008	14 - 56										
97095-06010	10 - 18										
	17 - 39										
97095-06012	13 - 4										
97095-06014	10 - 15										
	11 - 9										
97095-06016	1 - 9										
	3 - 5										
	4 - 4										
	9 - 4										
	10 - 10										
	11 - 10										
97095-06020	6 - 2										
	9 - 7										
	10 - 2										
	13 - 26										
	16 - 10										
	17 - 60										
97095-06025	15 - 4										
	15 - 13										
97095-06030	8 - 24										
97095-06045	17 - 28										
	21 - 20										
97095-08030	12 - 9										
97095-08055	12 - 7										
97575-08550	16 - 7										
97575-08555	15 - 26										
97595-06550	6 - 36										
97780-40112	17 - 20										
97780-40520	13 - 13										
	13 - 15										