



**PARTS
CATALOGUE
CATALOGO
DE REPUESTOS**

115BET'08 (6E58)
140BET'08 (6F38)

115BET/140BET
PARTS CATALOGUE
©2007 by Yamaha Motor Co., Ltd.
1st edition, September 2007
All rights reserved.
Any reprinting or unauthorized use
without the written permission of
Yamaha Motor Co., Ltd.
is expressly prohibited.
Printed in Japan.

115BET/140BET
CATALOGO DE REPUESTOS
©2007 por Yamaha Motor Co., Ltd.
1ª edición, septiembre 2007
Todos los derechos reservados.
Toda reproducción o uso no autorizado
sin el consentimiento escrito de
Yamaha Motor Co., Ltd.
quedan expresamente prohibidos
Impreso en Japón.

FOREWORD

This Parts Catalogue is related to the parts for the model(s) on the cover page. When you are ordering replacement parts, please refer to this Parts Catalogue and quote both part numbers and part names correctly.

1. Modifications or additions which have been made after the issue of the Parts Catalogue will be announced in the Parts News.
It is advisable that you make the necessary corrections to the Parts Catalogue according to the Parts News.

2. Abbreviations

The following abbreviations are used in this Parts Catalogue.

- “UR” Use specified parts number.
- “UN” Use as many as needed.
- “AP” Alternate Parts
- “LM” Locally Made (Parts need to be ordered locally)
- “F#” Frame No. (Applicable machine No.)
- “O/S” Over Size

3. The number of components for assembly

- Parts, which are to be supplied in an assembly, are listed with a dot (.) in front of the part name as shown below.
- The numeral appearing to the right of each component part indicates the quantity of parts for each assembly unit.

PART NO.	DESCRIPTION	Q'TY	REMARKS
2F5-83310-60	FRONT FLASHER LIGHT ASSY	2	
115-83311-60	.BULB (6V-18W)	1	

4. Applicable colours of graphics are represented in the “REMARKS” as shown below.

PART NO.	DESCRIPTION	Q'TY	REMARKS
2N4-24110-00-X5	FUEL TANK COMP.	2	MXR
3J1-24240-10	.GRAPHIC, FUEL TANK	1	FOR MXR

5. Note that the illustrations for reference in finding parts numbers are not to be used for assembling. When assembling, please use the applicable service manual.

6. The asterisk (*) before a reference number indicates modified items after the first edition.

7. Applicable Serial No.

Engine Serial No.

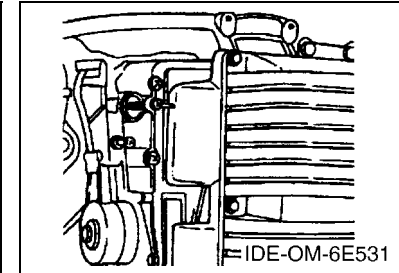
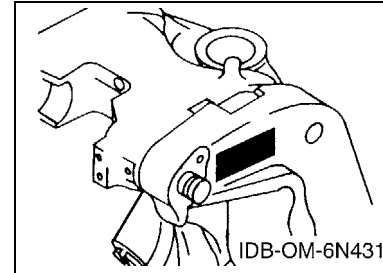

8. Applicable Engine Starting Serial No.

Model	Serial No.	Model	Serial No.
115B	6E5-1021119	140B	6F3-1001125

9. Applicable Colour Code

Abbreviation	Colour Name	Colour Code
DBNM2	DARK BLUISH GRAY METALLIC 2	004D

10. Quantity Column Information

Column No.	Name Of Q'ty Column	Applicable Model
1	6E58	115BET
2	6F38	140BET

PROLOGO

Este catálogo de repuestos corresponde a las piezas para el o los modelos que figuran en la página de portada. Al formular el pedido de repuestos, se ruega citar este catálogo y especificar correctamente el número y el nombre de las piezas.

- Las modificaciones y agregados que se hayan realizado después de la edición de este Catálogo de Repuestos, serán anunciados en las Informaciones de Recambios. Es recomendable que se hagan las correcciones necesarias en el Catálogo de Repuestos de acuerdo con las Informaciones de Recambios.

2. Abreviaciones

En este. Catálogo de Repuestos se emplean las siguientes abreviaciones.

“UR” Usar el número de partes especificado

“UN” Usar la cantidad necesaria

“AP” Piezas sustitutivas

“LM” Fabricación local (Hay que pedir los repuestos en las cercanías)

“F#” N° de bastidor (N° aplicable a la máquina)

“O/S” Sobredimensionado

3. La cantidad de componentes para el montaje

- Los componentes, suministrados como conjunto, se describen con un punto (.) que precede al nombre del parte como se indica a continuación.
- La numeración que aparece a la derecha de cada descripción indica la cantidad de partes por cada unidad de conjunto.

CODIGO N°	DESCRIPCION	CANT.	OBSERVACIONES
2F5-83310-60	ENSAMBLAJE DE LA LUZ	2	
115-83311-60	.BOMBILLA (6V-18W)	1	

4. Los colores de los componentes se indican como sigue en la columna de “OBSERVACIONES”.

CODIGO N°	DESCRIPCION	CANT.	OBSERVACIONES
2N4-24110-00-X5	COMP. DEL TANQUE	2	MXR
3J1-24240-10	.GRAFICO, DEL TANQUE	1	PARA MXR

- Debe tenerse en cuenta que las ilustraciones sirven como guía para la búsqueda de los números de partes y no deben usarse para el montaje. Durante el montaje, se recomienda usar el manual de taller correspondiente.

- EL asterisco (*) antes del número de referencia indica los elementos modificados después de la primera edición.

7. Números de serie

N° de Serie del motor

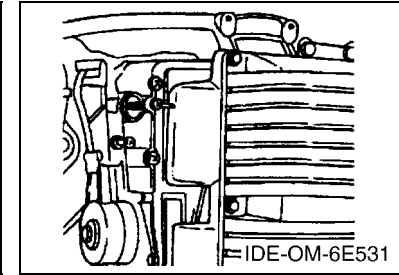
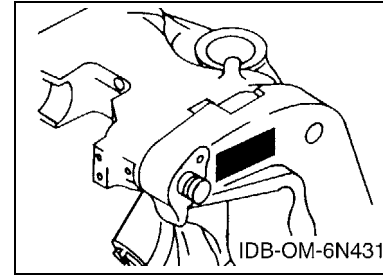

8. Números de serie del motor

Modelo	N° de serie	Modelo	N° de serie
115B	6E5-1021119	140B	6F3-1001125

9. Códigos de color aplicables

Abreviatura	Nombre de color	Código de color
DBNM2	DARK BLUISH GRAY METALLIC 2	004D

10. Información para la columna de cantidades

Columna N°	Nombre de la columna de cantidades	Modelo aplicable
1	6E58	115BET
2	6F38	140BET

CONTENTS

TOP COWLING	1
CYLINDER & CRANKCASE 1	2
CRANKSHAFT & PISTON	4
CYLINDER & CRANKCASE 2	6
INTAKE	8
CARBURETOR	10
FUEL	12
GENERATOR	14
ELECTRICAL 1	15
ELECTRICAL 2	16
STARTING MOTOR	18
BOTTOM COWLING	19
CONTROL	21
BRACKET 1	24
BRACKET 2	26
POWER TRIM & TILT ASSY 1	28
POWER TRIM & TILT ASSY 2	30
UPPER CASING	32
LOWER CASING & DRIVE 1	34
LOWER CASING & DRIVE 2	38
FUEL TANK	40
REMOTE CONTROL BOX	41
REMOTE CONTROL ASSY	42
METER	45
REPAIR KIT 1	46
REPAIR KIT 2	48

INDEX

NUMERICAL INDEX	50
-----------------------	----

CONTENIDO

SOPORTE SUPERIOR	1
CILINDRO & CARTER 1	2
CIGUENAL & PISTON	4
CILINDRO & CARTER 2	6
ADMISION	8
CARBURADOR	10
COMBUSTIBLE	12
GENERADOR	14
EQUIPO ELECTRICO 1	15
EQUIPO ELECTRICO 2	16
MOTOR DE ARRANQUE	18
CUBIERTA INFERIOR	19
CONTROL	21
SOPORTE 1	24
SOPORTE 2	26
COMPONER Y PODER VARILLA 1	28
COMPONER Y PODER VARILLA 2	30
FUNDA SUPERIOR	32
IMPULSOR E INFERIOR 1	34
IMPULSOR E INFERIOR 2	38
DEPOSITO DE COMBUSTIBLE	40
CONTROL REMOTO COMPLETO	41
CONTROL REMOTO COMPL	42
MEDIDOR	45
ESTUCHE REPARATION 1	46
ESTUCHE REPARATION 2	48

INDICE

INDICE NUMERICO	50
-----------------------	----

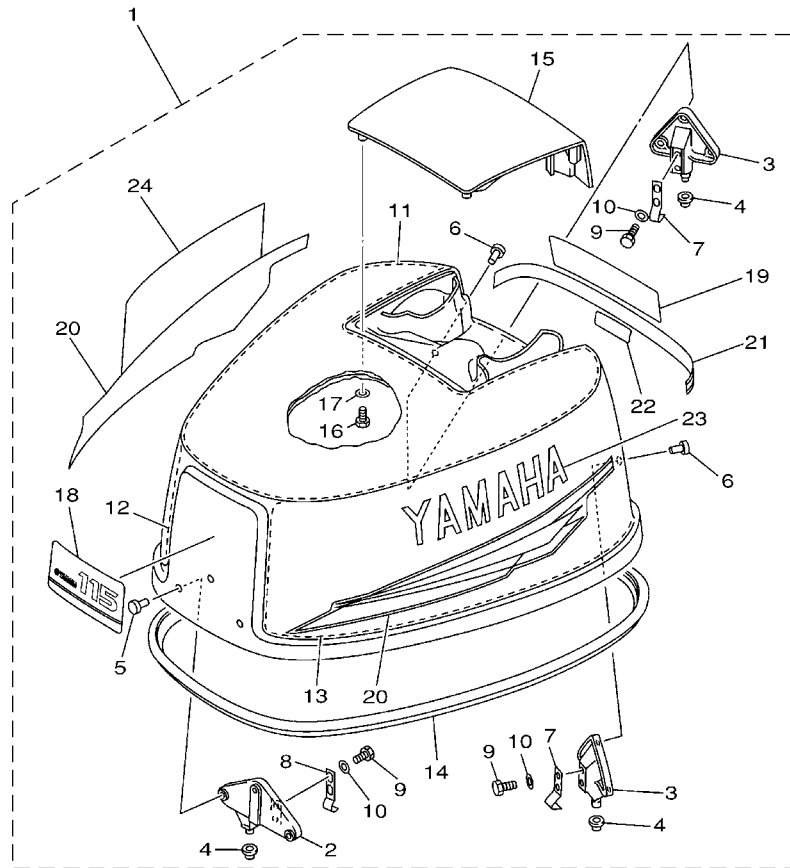

6E51200-2010

FIG. 1 TOP COWLING

SOPORTE SUPERIOR

REF. NO.	PART NO. CODIGO Nº	DESCRIPTION DESCRIPCION	6E58	6F38	REMARKS OBSERVACIONES
1	6E5-42610-80-4D	TOP COWLING ASSY SOPORTE SUPERIOR COMPL.	1		
	6F3-42610-40-4D	TOP COWLING ASSY SOPORTE SUPERIOR COMPL.		1	
2	6E5-42647-00-94	.HOLDER, CLAMP BAND .MORDAZA DE ABRAZADERA	1	1	
3	6E5-42649-01-94	.HOLDER, CLAMP BAND .MORDAZA DE ABRAZADERA	2	2	
4	663-42662-00	.DAMPER .AMORTIGUADOR	3	3	
5	90266-06009	.RIVET .REMACHE	3	3	
6	90266-06M02	.RIVET .REMACHE	6	6	
7	6E5-42652-00	.HOOK .GANCHO	2	2	
8	688-42652-00	.HOOK .GANCHO	1	1	
9	97095-06016	.BOLT .PERNO	6	6	
10	92995-06600	.WASHER .ARANDELA	6	6	
11	6E5-42617-00	.DAMPER, FORM .HULE DE FORMA	1	1	
12	6E5-42619-00	.DAMPER, FORM .HULE DE FORMA	1	1	
13	6E5-42627-00	.DAMPER, FORM .AMORTIGUADOR FORMA 3	1	1	
14	6E5-42615-00	.SEAL .SELLO	1	1	
15	6E5-42613-01-4D	.MOLDING, AIR DUCT .MOLDURA CONDUCTO AIRE	1	1	
16	97095-06016	.BOLT .PERNO	4	4	
17	92995-06600	.WASHER .ARANDELA	4	4	
18	6E5-42677-40	.GRAPHIC, FRONT .CALCAMONIA FRONTAL	1		
	6F3-42677-40	.GRAPHIC, FRONT .CALCAMONIA FRONTAL		1	
19	6E5-42678-31	.GRAPHIC, REAR .CALCAMONIA TRASERA	1		
	6F3-42678-31	.GRAPHIC, REAR .CALCAMONIA TRASERA		1	
20	6N7-W0070-30	.GRAPHIC SET .JUEGO DE EMBLEMA	1	1	
21	6E5-4267A-31	.GRAPHIC, REAR 2 .CALCAMONIA TRASERA 2	1	1	
22	6N7-42678-30	.GRAPHIC, REAR .CALCAMONIA TRASERA	1	1	
23	6N7-42681-30	.MARK, COWLING .MARCA DE CUBIERTA	1	1	
24	6N7-42682-30	.MARK, COWLING .MARCA DE CUBIERTA	1	1	

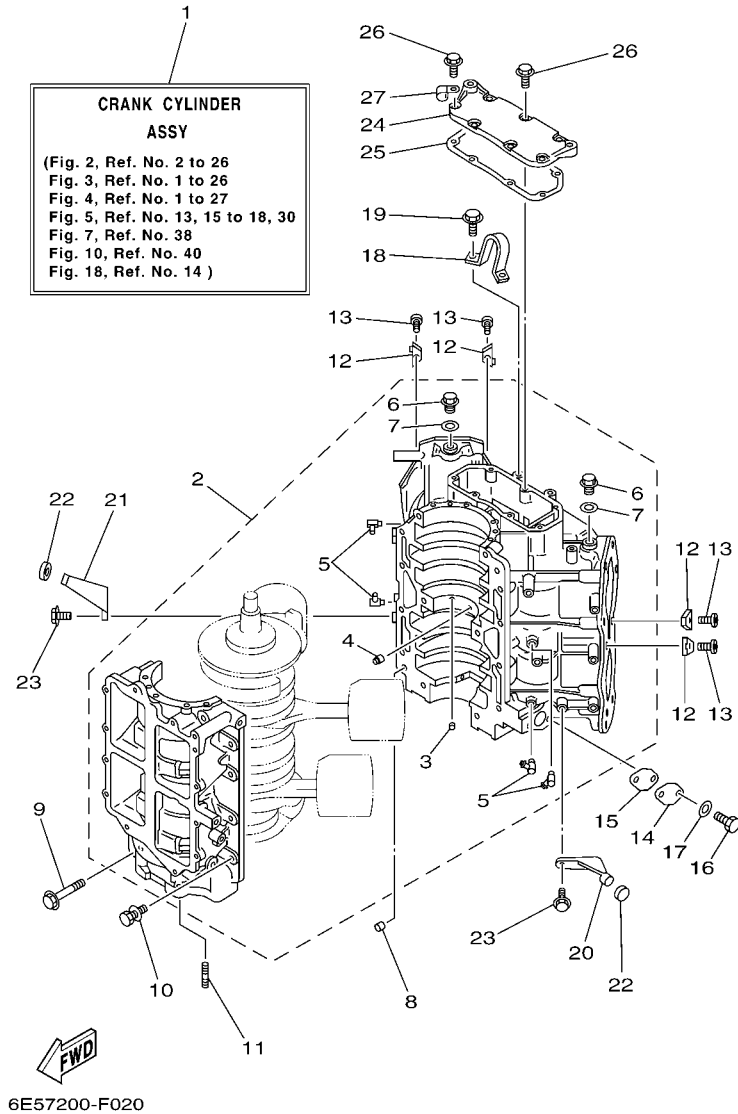
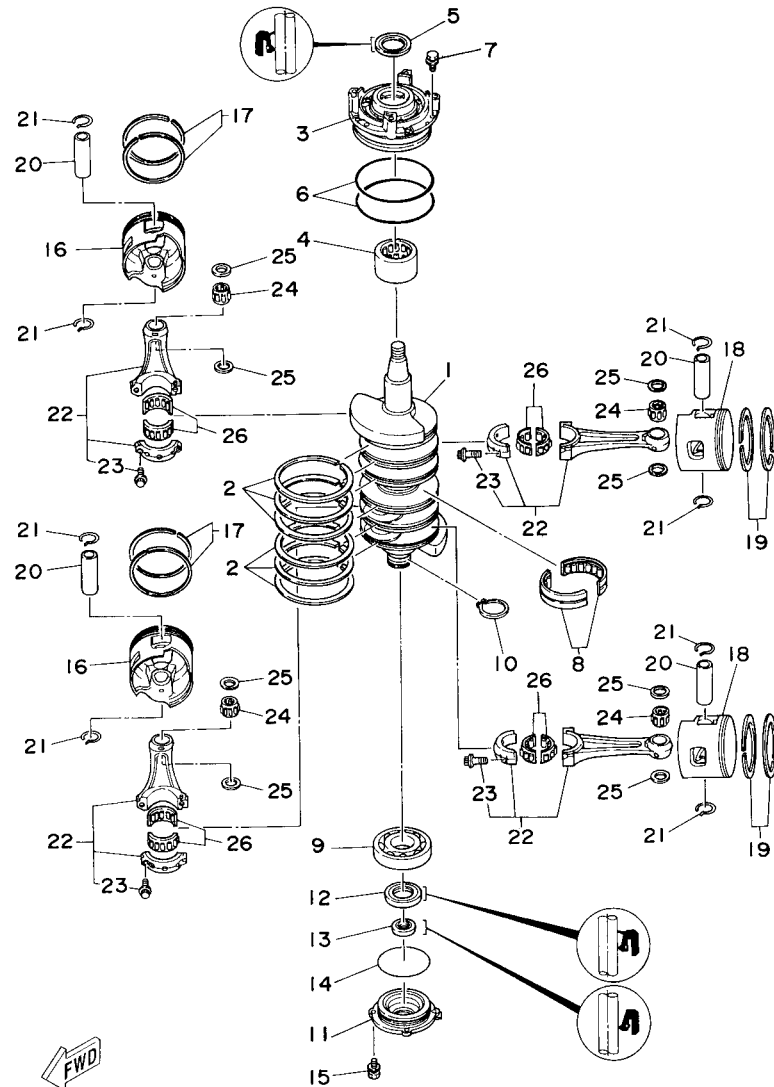

FIG. 2 CYLINDER & CRANKCASE 1 CILINDRO & CARTER 1

REF. NO.	PART NO. CODIGO Nº	DESCRIPTION DESCRIPCION	6E58	6F38		REMARKS OBSERVACIONES
1	6E5-W0090-56-1S	CRANK CYLINDER ASSY BLOQUE MOTOR COMPLETO	1			
	6F3-W0090-67-1S	CRANK CYLINDER ASSY BLOQUE MOTOR COMPLETO		1		
2	6N6-15100-01-1S	CRANKCASE ASSY CARTER COMPLETO	1			
	6N7-15100-01-1S	CRANKCASE ASSY CARTER COMPLETO		1		
3	624-11379-00	.VALVE, CHECK .VALVULA DE CONTROL	1	1		
4	663-11518-01	.LOCK, BEARING .SEGURO BALERO	1	1		
5	6E5-11372-01	.NIPPLE, HOSE .NIPLE DE MANGUERA	4	4		
6	90340-14M00	.PLUG, STRAIGHT SCREW .TORNILLO, DE DRENAJE	2	2		
7	90430-14115	.GASKET .JUNTA	2	2		
8	93608-12063	PIN, DOWEL PASADOR DE CLAVIJA	2	2		
9	90105-10M20	BOLT, FLANGE TORNILLO	6	6		
10	90119-08M94	BOLT, WITH WASHER TORNILLO CON ARANDELA	8	8		
11	90116-08026	BOLT, STUD ESPARRAGO	2	2		
12	6E5-11325-00	ANODE ANODO	4	4		
13	98780-04015	SCREW, FLAT HEAD TORNILLO CABEZA PLANA	4	4		
14	6R3-1131M-01	COVER CUBIERTA	1	1		
15	6R3-11397-01	GASKET EMPAQUE	1	1		
16	97013-06016	BOLT PERNO	2	2		
17	92903-06600	WASHER, PLATE RONDANA SENCILLA	2	2		
18	6E5-11119-01	HANGER, ENGINE SOPORTE DEL MOTOR	1	1		
19	90119-08MA3	BOLT, WITH WASHER TORNILLO CON ARANDELA	2	2		
20	6E5-42761-00-1S	STOPPER RETEN 1	1	1		
21	6E5-42762-00-1S	STOPPER RETEN 2	1	1		
22	68F-44533-00	DAMPER, UPPER MOUNT RUBBER AMORTIGUADOR SUPERIOR	2	2		
23	90119-06MA2	BOLT, WITH WASHER TORNILLO CON ARANDELA	4	4		
24	6E5-11371-00-1S	COVER CUBIERTA 1	1	1		
25	6E5-11381-A2	GASKET 1 EMPAQUE 1	1	1		



6E52010-3030

FIG. 3 CRANKSHAFT & PISTON

CIGUENAL & PISTON

REF. NO.	PART NO. CODIGO Nº	DESCRIPTION DESCRIPCION	6E58	6F38	REMARKS OBSERVACIONES
1	6N7-11411-01	CRANKSHAFT CIGUENAL	1	1	
2	6E5-11447-00	SEAL, CRANK SELLO MANIVELA	6	6	
3	6E5-15163-00-1S	HOUSING, BEARING 1 CAJA DE COJINETE 1	1	1	
4	93311-940U3	BEARING COJINETE DE RODILLOS	1	1	
5	93102-40M14	OIL SEAL SELLO ACEITE	1	1	
6	93211-04001	O-RING ANILLO O	2	2	
7	90119-06MA2	BOLT, WITH WASHER TORNILLO CON ARANDELA	4	4	
8	93310-954U1	BEARING COJINETE DE RODILLOS	1	1	
9	93306-208U0	BEARING COJINETE	1	1	
10	93410-40M03	CIRCLIP SEGURO	1	1	
11	6G5-15359-00-94	HOUSING, OIL SEAL CAJA DE SELLO DE ACEITE	1	1	
12	93102-35M13	OIL SEAL SELLO ACEITE	1	1	
13	93101-22M15	OIL SEAL SELLO ACEITE	1	1	
14	93210-74M35	O-RING ANILLO O	1	1	
15	90119-06MA2	BOLT, WITH WASHER TORNILLO CON ARANDELA	4	4	
16	6R5-11631-11-93	PISTON (STD) PISTON (NORMA)	2	2	
	6R5-11635-11	PISTON (0.25MM O/S) PISTON (0.25MM O/S)	2	2	AP AP
	6R5-11636-11	PISTON (0.50MM O/S) PISTON (0.50MM O/S)	2	2	AP AP
17	64D-11603-02	PISTON RING SET (STD) JUEGO DE ANILLOS (NORMA)	2	2	
	64D-11604-02	PISTON RING SET (0.25MM O/S) JUEGO DE ANILLOS (0.25MM O/S)	2	2	AP AP
	64D-11605-02	PISTON RING SET (0.50MM O/S) JUEGO DE ANILLOS (0.50MM O/S)	2	2	AP AP
18	6R5-11642-11-93	PISTON 2 (STD) PISTON 2 (NORMA)	2	2	
	6R5-11645-11	PISTON 2 (0.25MM O/S) PISTON 2 (0.25MM O/S)	2	2	AP AP
	6R5-11646-11	PISTON 2 (0.50MM O/S) PISTON 2 (0.50MM O/S)	2	2	AP AP
19	64D-11603-02	PISTON RING SET (STD) JUEGO DE ANILLOS (NORMA)	2	2	
	64D-11604-02	PISTON RING SET (0.25MM O/S) JUEGO DE ANILLOS (0.25MM O/S)	2	2	AP AP
	64D-11605-02	PISTON RING SET (0.50MM O/S) JUEGO DE ANILLOS (0.50MM O/S)	2	2	AP AP

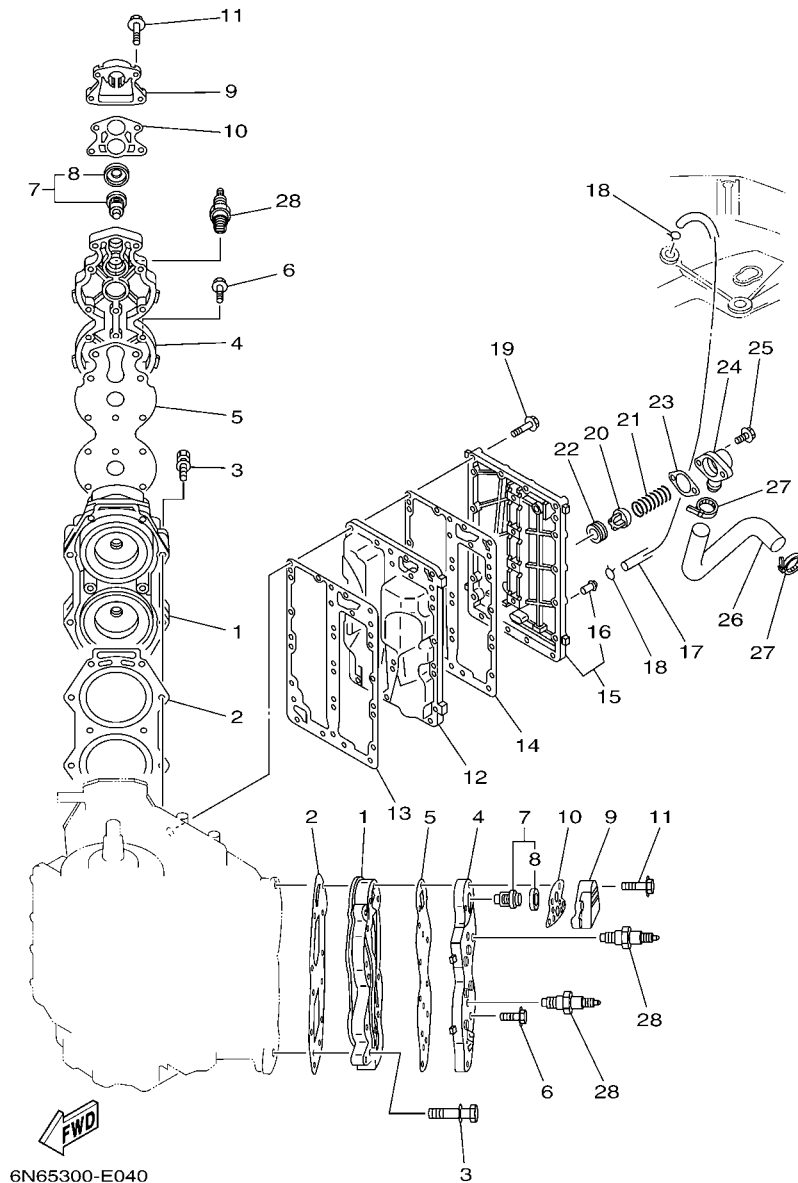
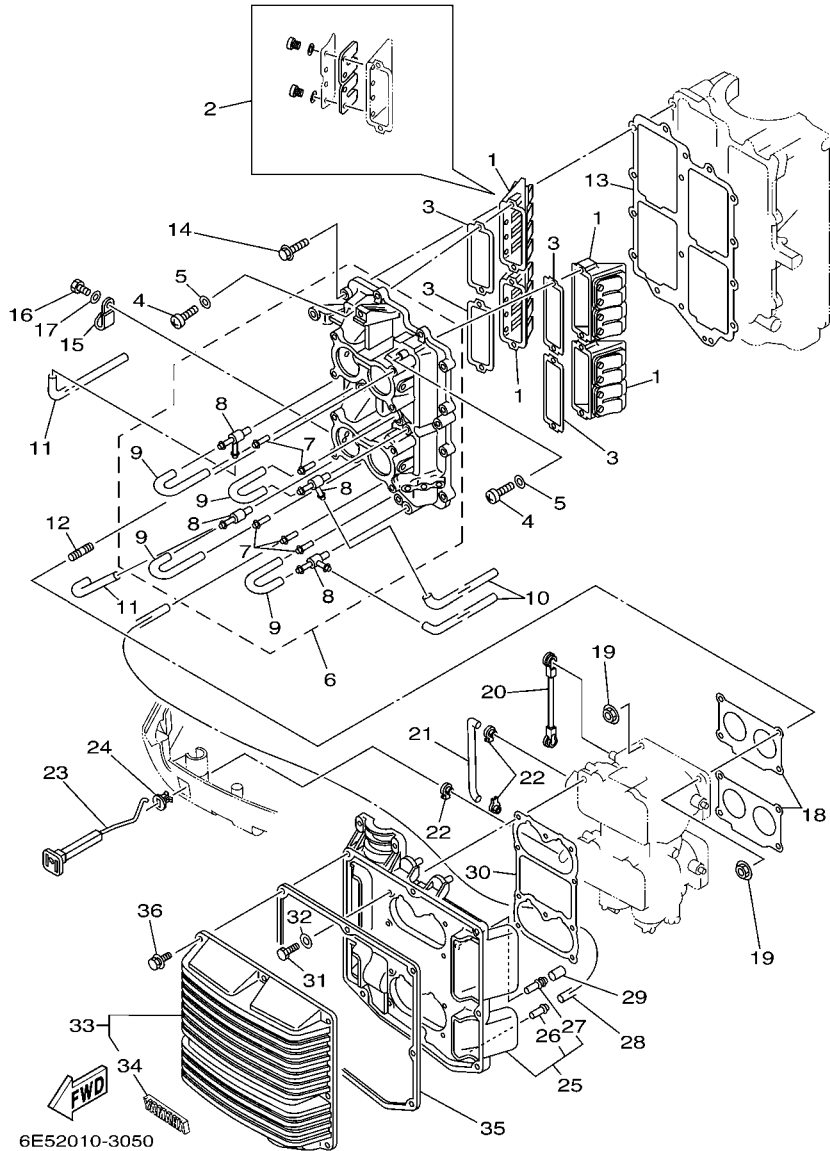

FIG. 4 CYLINDER & CRANKCASE 2 CILINDRO & CARTER 2

REF. NO.	PART NO. CODIGO Nº	DESCRIPTION DESCRIPCION	6E68	6F38		REMARKS OBSERVACIONES
1	6E5-11111-10-1S	HEAD, CYLINDER 1 CULATA CILINDRO 1	2			
	6L1-11111-00-1S	HEAD, CYLINDER 1 CULATA CILINDRO 1		2		
2	6E5-11181-A1	GASKET, CYLINDER HEAD 1 JUNTA, DE CULATA 1	2	2		
3	90119-08MA8	BOLT, WITH WASHER TORNILLO CON ARANDELA	20	20		
4	6E5-11191-01-1S	COVER, CYLINDER HEAD 1 TAPA CULATA DE CILINDRO 1	2	2		
5	6E5-11193-A0	GASKET, HEAD COVER 1 EMPAQUE	2	2		
6	90119-06MA4	BOLT, WITH WASHER TORNILLO CON ARANDELA	24	24		
7	6E5-12411-30	THERMOSTAT TERMOSTAT	2	2		
8	688-12412-00	.SEAL, THERMOSTAT .SELLO TERMOSTATO	1	1		
9	6G5-12413-00-1S	COVER, THERMOSTAT CUBIERTA TERMOSTATO	2	2		
10	688-12414-A1	GASKET, COVER EMPAQUE	2	2		
11	90119-06MA6	BOLT, WITH WASHER TORNILLO CON ARANDELA	8	8		
12	6E5-41111-00-1S	INNER COVER, EXHAUST CUBIERTA INTERIOR DE ESCAPE	1			
	6L1-41111-00-1S	INNER COVER, EXHAUST CUBIERTA INTERIOR DE ESCAPE		1		
13	6E5-41112-A1	GASKET, EXHAUST INNER COVER EMPAQUE	1	1		
14	6E5-41114-A0	GASKET, EXHAUST OUTER COVER EMPAQUE	1	1		
15	6N7-41113-00-1S	OUTER COVER, EXHAUST CUBOERTA EXTERIOR DE ESCAPE	1	1		
16	650-24378-00	.PIPE, JOINT 4 .TUBO DE UNION 3	1	1		
17	6E5-24312-00	PIPE 2 TUBO 2	1	1		
18	90467-08004	CLIP PRESILLA	2	2		
19	90119-06MA5	BOLT, WITH WASHER TORNILLO CON ARANDELA	23	23		
20	60H-12416-00	VALVE, PRESSURE CONTROL VALVULA DE CONTROL DE PRESION	1	1		
21	90501-16M11	SPRING, COMPRESSION RESORTE DE COMPRESION	1	1		
22	90480-20M05	GROMMET TAPON	1	1		
23	6G5-11382-A1	GASKET 2 EMPAQUE 2	1	1		
24	6G5-11372-00-1S	COVER, BYPASS 2 CUBIERTA	1	1		
25	97595-06420	BOLT, WITH WASHER PERNO CON ARANDELA	2	2		



6E52010-3050

FIG. 5 INTAKE

ADMISION

REF. NO.	PART NO. CODIGO Nº	DESCRIPTION DESCRIPCION	6E58	6F38	REMARKS OBSERVACIONES
1	6E5-13610-00	REED VALVE ASSY VALVULA DE LAMINAS COMPLETA	4	4	
2	6E5-W0004-00	.REED SET .JUEGO DE VALVULAS DE LENGUETA	1	1	
3	6E5-13621-A1	GASKET, VALVE SEAT JUNTA, DE VALV.DE EMPAQUE	4	4	
4	97880-05025	SCREW, PAN HEAD TORNILLO DE CABEZA CON PLANA	8	8	
5	92990-05600	WASHER, PLATE ARANDELA PLANA	8	8	
6	6E5-13641-03-1S	MANIFOLD 1 MULTIPLE 1	1	1	
7	624-14485-00	.PIPE, JOINT .TUBO DE UNION	5	5	
8	6E5-11370-01	.CHECK VALVE ASSY .VALVULA DE CONTROL COMPL.	4	4	
9	90445-07M28	.HOSE (L70) .TUBO (L70)	4	4	
10	90445-07M24	HOSE (L240) TUBO (L240)	2	2	
11	90445-07M46	HOSE (L360) TUBO (L360)	2	2	
12	90116-06M30	BOLT, STUD ESPARRAGO	8	8	
13	6E5-13645-A1	GASKET, MANIFOLD 1 EMPAQUE	1	1	
14	90119-06MA3	BOLT, WITH WASHER TORNILLO CON ARANDELA	12	12	
15	90465-06M86	CLAMP BRIDA	1	1	
16	97095-06012	BOLT PERNO	1	1	
17	92995-06600	WASHER ARANDELA	1	1	
18	6E5-14198-A2	GASKET EMPAQUE	2	2	
19	90179-06M28	NUT TUERCA	8	8	
20	6E5-41217-01	ROD, ACCEL. LEVER VARILLA PALANCA ACELERADOR	1	1	
21	6E5-41256-01	ROD, CHOKE 1 VARILLA DE AHOGADOR	1	1	
22	661-41262-02	JOINT, CHOKE LEVER CONECTOR DE AHOGADOR	3	3	
23	6E5-41271-02	KNOB, CHOKE PERILLA AHOGADOR	1	1	
24	689-41273-00	GROMMET TAPON PROTECTOR	1	1	
25	6E5-14417-10-94	COVER 1 CUBIERTA 1	1	1	
26	624-14485-00	.PIPE, JOINT .TUBO DE UNION	1	1	
27	6E5-14485-00	.PIPE, JOINT .TUBO DE UNION	1	1	

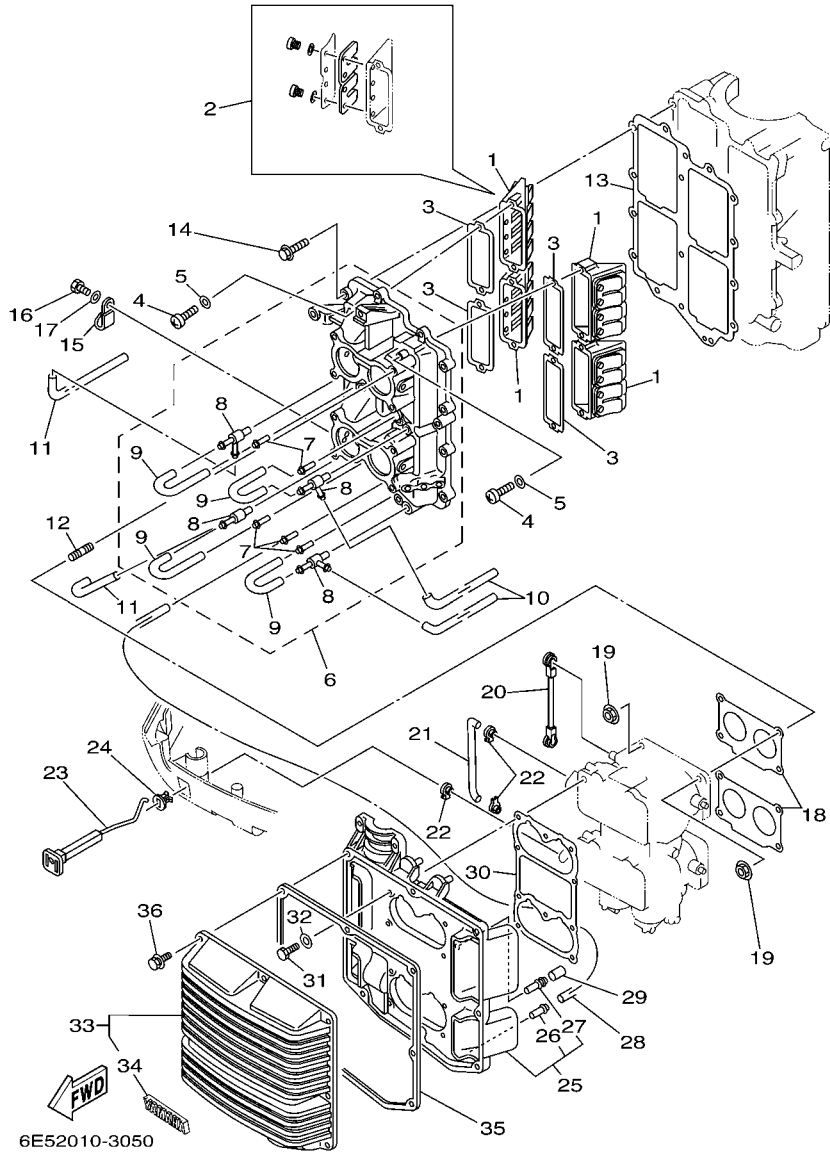

FIG. 5 INTAKE

ADMISION

REF. NO.	PART NO. CODIGO Nº	DESCRIPTION DESCRIPCION	6E58	6F38		REMARKS OBSERVACIONES
28	90445-07M23	HOSE (L408) TUBO (L408)	1	1		
29	647-14395-60	CAP, OVERFLOW PIPE TAPA DE TUBO REBOSAMIENTO	1	1		
30	6E5-14483-A1	GASKET EMPAQUE	1	1		
31	97013-06020	BOLT PERNO	8	8		
32	92903-06600	WASHER, PLATE RONDANA SENCILLA	8	8		
33	6E5-14418-00	COVER 2 CUBIERTA 2	1	1		
34	6E5-1441K-00	.EMBLEM .EMBLEMA	1	1		
35	6E5-14416-A1	GASKET, AIR CLEANER EMPAQUE	1	1		
36	90119-06M31	BOLT, WITH WASHER TORNILLO CON ARANDELA	8	8		
<hr/>						
<hr/>						
<hr/>						
<hr/>						
<hr/>						
<hr/>						
<hr/>						
<hr/>						
<hr/>						
<hr/>						

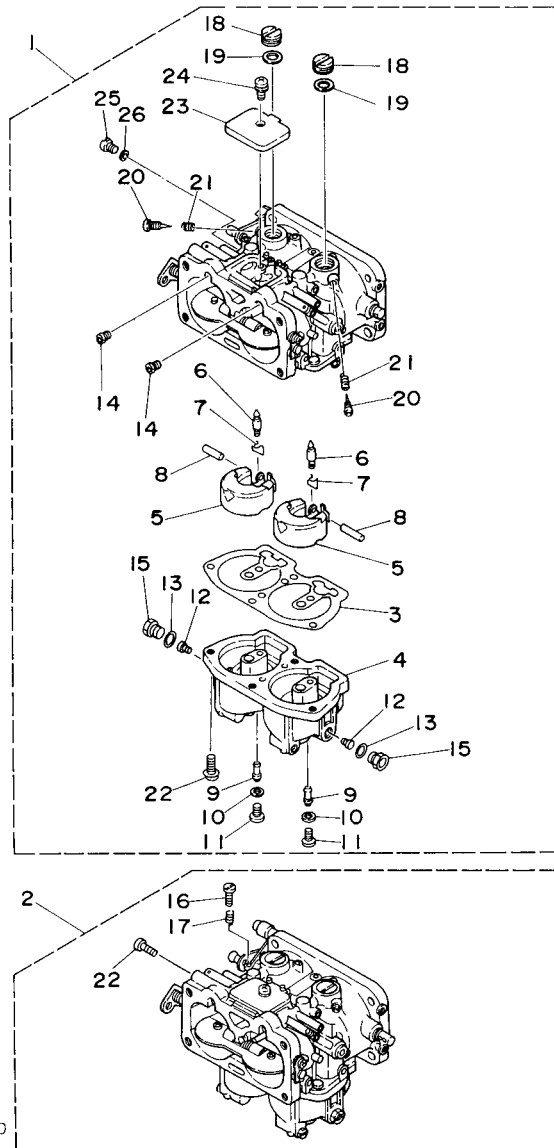

FIG. 6 CARBURETOR

CARBURADOR

REF. NO.	PART NO. CODIGO Nº	DESCRIPTION DESCRIPCION	6E58	6F38	REMARKS OBSERVACIONES
1	6E5-14301-17	CARBURETOR ASSY 1 CARBURADOR COMPLETO 1	1		
	6L1-14301-05	CARBURETOR ASSY 1 CARBURADOR COMPLETO 1		1	
2	6E5-14302-17	CARBURETOR ASSY 2 CARBURADOR COMPLETO 2	1		
	6L1-14302-05	CARBURETOR ASSY 2 CARBURADOR COMPLETO 2		1	
3	64D-14384-01	.GASKET, FLOAT CHAMBER .EMPAQUE DE CAMARA DE BOIA	2	2	
4	64D-14381-00	.BODY, FLOAT CHAMBER .CUERPO DE CAMARA DE BOIA	2	2	
5	6E5-14385-02	.FLOAT .BOIA	4	4	
6	6E5-14546-00	.VALVE, NEEDLE .VALVULA DE AGUJA	4	4	
7	6E5-14159-00	.CLIP .PRESILLA	4	4	
8	6E5-14386-02	.PIN, FLOAT .PASADOR DE BOIA	4	4	
9	64D-1492F-39	.JET, AIR SLOW (#78) .ESPREA (#78)	4		
	64D-1492F-41	.JET, AIR SLOW (#82) .ESPREA (#82)		4	
10	61U-14959-00	.GASKET .EMPAQUE	4	4	
11	64D-14394-00	.VALVE, DRAIN .VALVULA DE DRENAJE	4	4	
12	64D-1492E-88	.JET, MAIN (#176) .INJECTOR, PRINCIPAL (#176)	4		
	64D-1492E-90	.JET, MAIN (#180) .INJECTOR, PRINCIPAL (#180)		4	
13	6E5-14398-00	.GASKET .EMPAQUE	4	4	
14	61A-1492H-12	.JET, SLOW AIR BLEED (#60) .ESPREA AIRE (#60)	4	4	
15	61A-14383-01	.SCREW, DRAIN .TORNILLO DE DRENAJE	4	4	
16	6E5-14321-00	.SCREW, THROTTLE .TORNILLO DE OBTURADOR	1	1	#2 #2
17	6J8-14334-00	.SPRING, THROTTLE .RESORTE DE AJUSTADOR DE AIRE	1	1	#2 #2
18	6E5-14328-01	.PLUG .TORNILLO TOPE DE PILOTO	4	4	
19	6E5-14979-00	.GASKET .EMPAQUE DE ARRANQUE	4	4	
20	6E5-14323-03	.SCREW, AIR ADJUSTING .TORNILLO DE AJUSTE DE AIRE	4	4	
21	6E5-14223-00	.SPRING, AIR ADJUSTING .RESORTE, AJUSTE DE AIRE	4	4	
22	97980-05116	.SCREW, WITH WASHER .TORNILLO, CON ARANDELA	9	9	
23	6E5-14527-01	.PLATE .PLACA	2	2	

FIG. 6 CARBURETOR

CARBURADOR

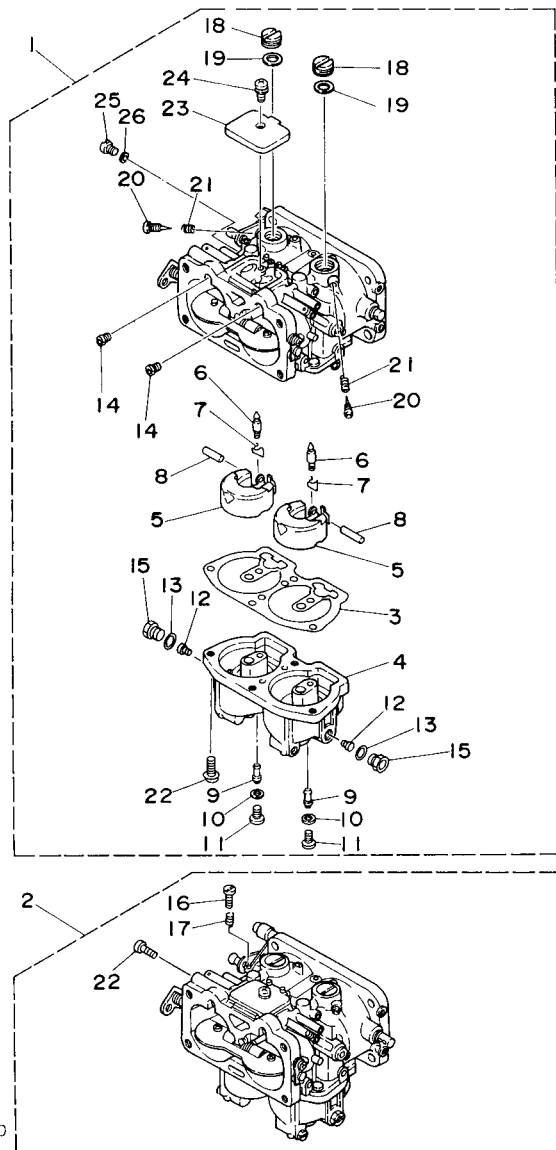

REF. NO.	PART NO. CODIGO Nº	DESCRIPTION DESCRIPCION	6E58	6F38		REMARKS OBSERVACIONES
24	97980-05108	.SCREW, WITH WASHER .TORNILLO, CON ARANDELA	2	2		
25	6E5-14324-00	.SCREW, FLAT HEAD .TORNILLO CABEZA PLANA	2	2		
26	6J8-14995-00	.GASKET .EMPAQUE	2	2		

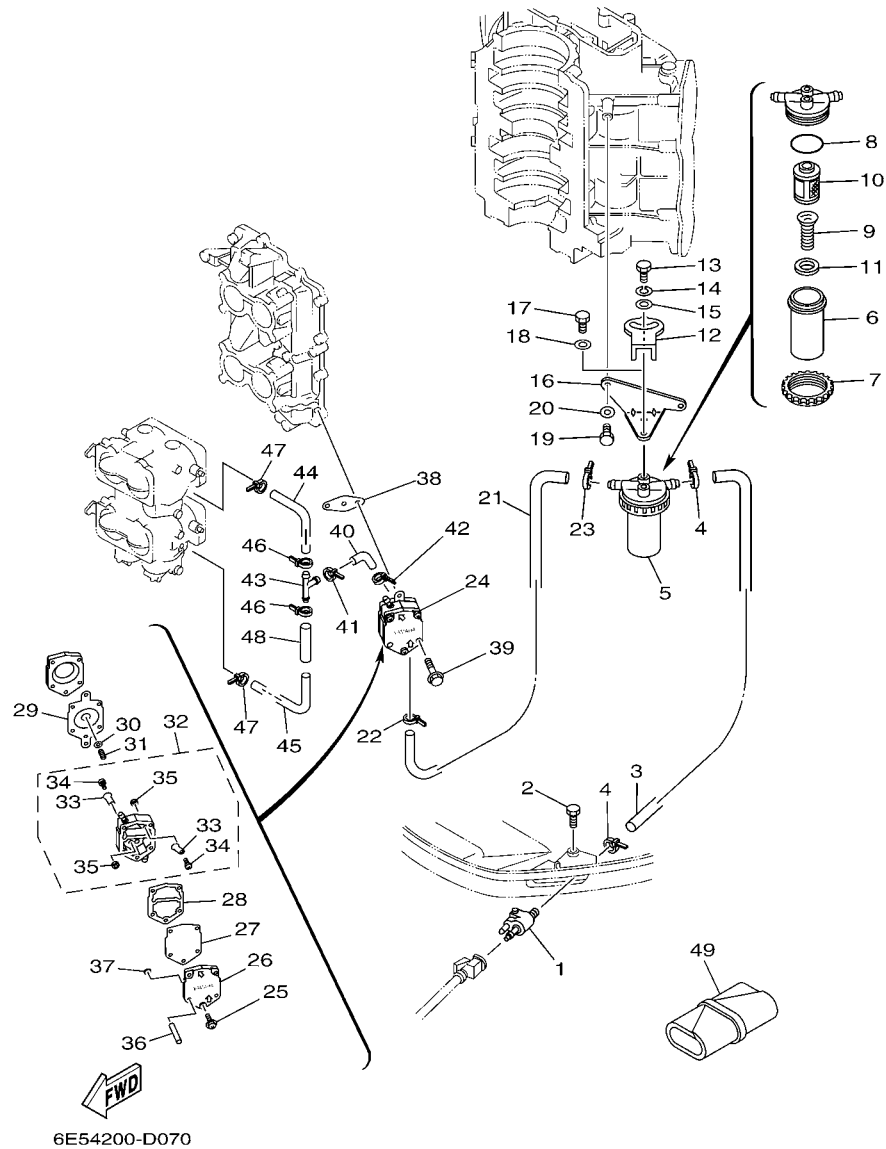

FIG. 7 FUEL

COMBUSTIBLE

REF. NO.	PART NO. CODIGO Nº	DESCRIPTION DESCRIPCION	6E58	6F38	REMARKS OBSERVACIONES
1	6E5-24304-10	FUEL PIPE JOINT COMP. 1 CONECTOR MANGUERA COMBUST.1	1	1	
2	97095-06028	BOLT PERNO	1	1	
3	61U-24313-00	PIPE 3 TUBO 3	1	1	
4	90465-11M10	CLAMP BRIDA	2	2	
5	61A-24560-04	FILTER ASSY FILTRO COMPLETO	1	1	
6	61A-24521-00	.CUP, FILTER .COPA DE FILTRO	1	1	
7	65L-24531-01	.NUT .TUERCA	1	1	
8	61A-24564-00	.O-RING .ANILLO O	1	1	
9	61A-24577-01	.SPRING .RESORTE	1	1	
10	61A-24563-00	.ELEMENT, FILTER .ELEMENTO DEL FILTRO	1	1	
11	61A-24469-00	.FLOAT, WATER LEVEL .BOIA	1	1	
12	60H-24558-00	HOLDER, FILTER SOPORTE DE FILTRO	1	1	
13	97095-06016	BOLT PERNO	1	1	
14	92995-06100	WASHER, SPRING ARANDELA	1	1	
15	90201-06068	WASHER, PLATE ARANDELA PLANA	1	1	
16	61U-24566-01	BRACKET, FILTER SOPORTE DEL FILTRO	1	1	
17	97095-06014	BOLT PERNO	1	1	
18	92995-06600	WASHER ARANDELA	1	1	
19	97095-06016	BOLT PERNO	2	2	
20	92995-06600	WASHER ARANDELA	2	2	
21	61U-24314-00	PIPE 4 TUBO 4	1	1	
22	90465-11M10	CLAMP BRIDA	1	1	
23	90465-11M10	CLAMP BRIDA	1	1	
24	6E5-24410-04	FUEL PUMP ASSY BOMBA DE COMBUSTIBLE COMPLETA	1	1	
25	6E5-24444-01	.SCREW .TORNILLO	3	3	
26	6E5-24413-01	.BODY 2 .CUERPO 2	1	1	
27	6E5-24471-01	.DIAPHRAGM .DIAFRAGMA	1	1	

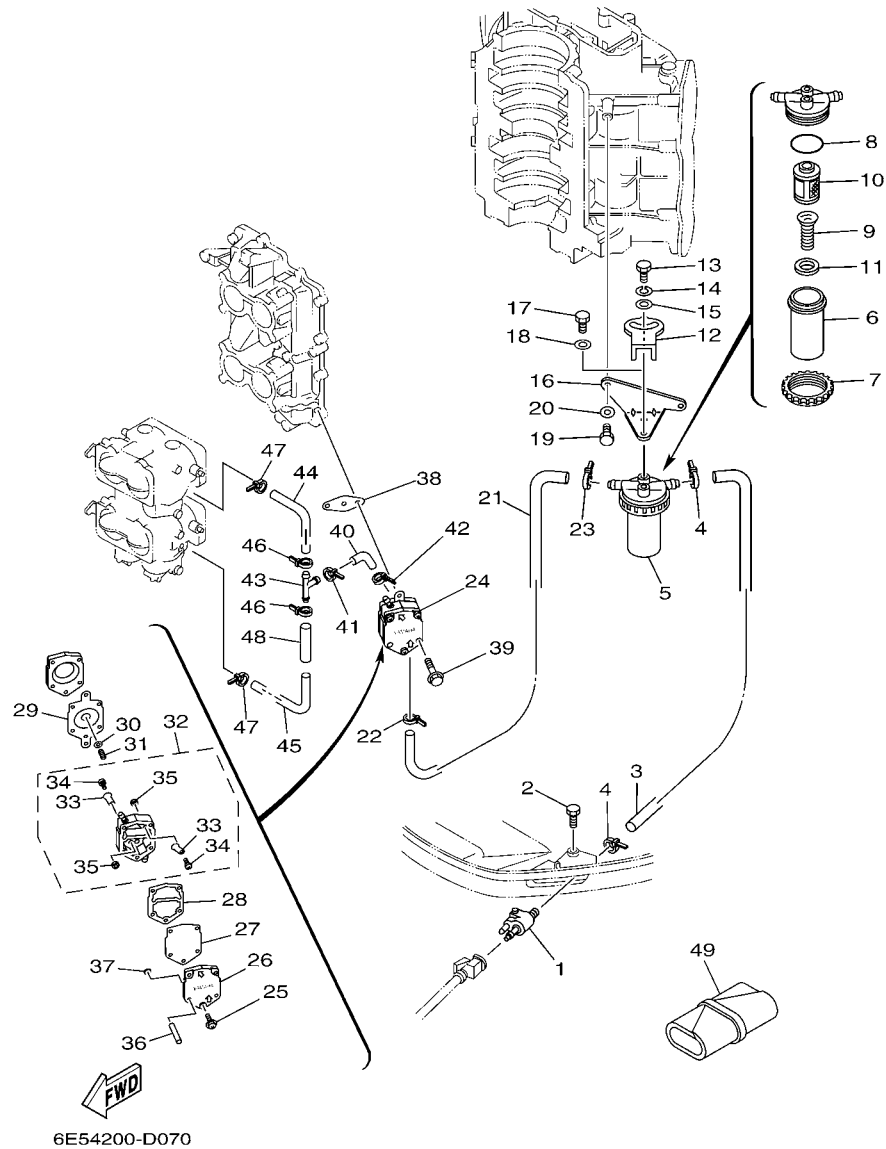
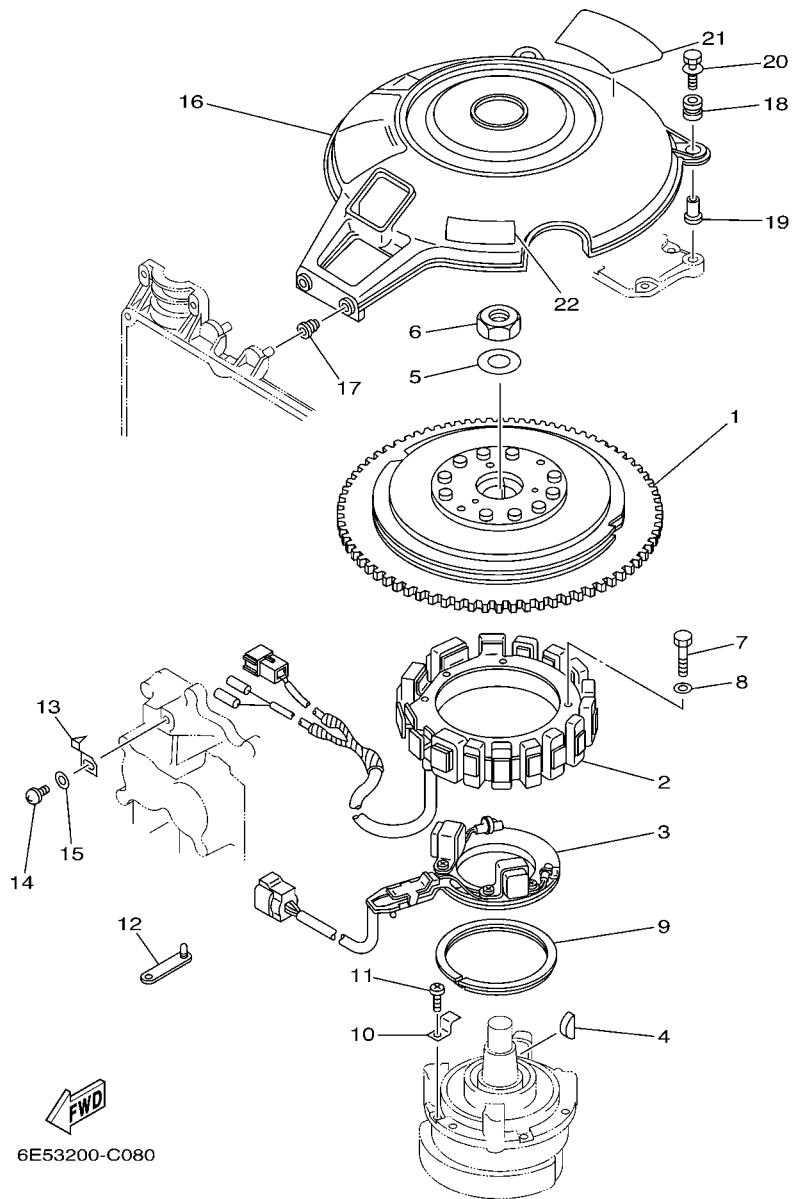

FIG. 7 FUEL

COMBUSTIBLE

REF. NO.	PART NO. CODIGO Nº	DESCRIPTION DESCRIPCION	6E58	6F38	REMARKS OBSERVACIONES
28	6E5-24435-01	.GASKET, BODY 2 .EMPAQUE	1	1	
29	6E5-24411-01	.DIAPHRAGM .DIAFRAGMA	1	1	
30	648-24424-00	.SEAT, SPRING .PLACA DE RESORTE	1	1	
31	6E5-24423-00	.SPRING, DIAPHRAGM .RESORTE DE DIAFRAGMA	1	1	
32	6E5-24412-11	.BODY 1 .CUERPO 1	1	1	
33	6A0-24421-01	..VALVE, CHECK ..VALVULA DE RETENCION	4	4	
34	6A0-14325-00	..SCREW, PAN HEAD ..TORNILLO CABEZA REDONDA	4	4	
35	95380-03600	..NUT ..TUERCA	4	4	
36	6E5-24492-00	.BUSH, FUEL PUMP .BUJE	2	2	
37	6E5-24486-00	.O-RING .ANILLO O	2	2	
38	650-24431-A0	GASKET, FUEL PUMP 1 EMPAQUE BOMBA COMBUST 1	1	1	
39	97595-06550	BOLT, WITH WASHER PERNO CON ARANDELA	2	2	
40	6G5-24316-10	PIPE 6 TUBO 6	1	1	
41	90465-11M10	CLAMP BRIDA	1	1	
42	90465-11M10	CLAMP BRIDA	1	1	
43	6E5-24376-10	PIPE, JOINT 1 TUBO DE UNION 1	1	1	
44	6G5-24318-10	PIPE, OVERFLOW TUBO DE REBOSAMIENTO	1	1	
45	6G5-24319-10	PIPE, OIL TUBO DE ACEITE	1	1	
46	90465-11M10	CLAMP BRIDA	2	2	
47	90465-11M10	CLAMP BRIDA	2	2	
48	90446-15M07	HOSE (L60) TUBO (L60)	1	1	
49	656-W2810-02	TOOL KIT JUEGO DE HERRAMIENTAS	1	1	



6E53200-C080

FIG. 8 GENERATOR

GENERADOR

REF. NO.	PART NO. CODIGO Nº	DESCRIPTION DESCRIPCION	6E58	6F38	REMARKS OBSERVACIONES
1	6E5-85550-00	ROTOR ASSY ROTOR COMPLETO	1	1	
2	6E5-85510-01	STATOR ASSY ESTATOR COMPLETO	1	1	
3	6E5-85580-00	COIL, PULSER BOBINA DE PULSACION	1	1	
4	90280-05015	KEY, WOODRUFF CUNA WOODRUFF	1	1	
5	90201-21M18	WASHER, PLATE ARANDELA PLANA	1	1	
6	90170-20137	NUT TUERCA	1	1	
7	97013-06060	BOLT PERNO	3	3	
8	92903-06600	WASHER, PLATE RONDANA SENCILLA	3	3	
9	688-41611-00	RETAINER, MAGNETO BASE RETENEDOR BASE MAGNETO	1	1	
10	688-41612-00	RETAINER, MAGNETO BASE RETENEDOR BASE MAGNETO	4	4	
11	97880-06018	SCREW, PAN HEAD TORNILLO DE CABEZA CON PLANA	4	4	
12	90464-12M00	CLAMP BRIDA	1	1	
13	6E5-81332-00	PLATE, TIMING PLACA REGULADOR DE TIEMPO	1	1	
14	97885-06010	SCREW, PAN HEAD TORNILLO A MUESCA	1	1	
15	92995-06600	WASHER ARANDELA	1	1	
16	6E5-81337-01	COVER, FLYWHEEL CUBIERTA DE VOLANTE	1	1	
17	6G5-82317-00	DAMPER, IGNITION COIL AMORTIGUADOR BOBINA ENCENDIDO	2	2	
18	6A0-82317-00	DAMPER, IGNITION COIL AMORTIGUADOR BOBINA ENCENDIDO	2	2	
19	90387-06119	COLLAR ESPACIADOR	2	2	
20	90119-06M65	BOLT, WITH WASHER TORNILLO CON ARANDELA	2	2	
21	6E5-14488-00	LABEL, CAUTION ETIQUETA PRECAUCION	1	1	
22	6A1-83625-41	MARK 5 MARCA 5	1	1	

FIG. 9 ELECTRICAL 1

EQUIPO ELECTRICO 1

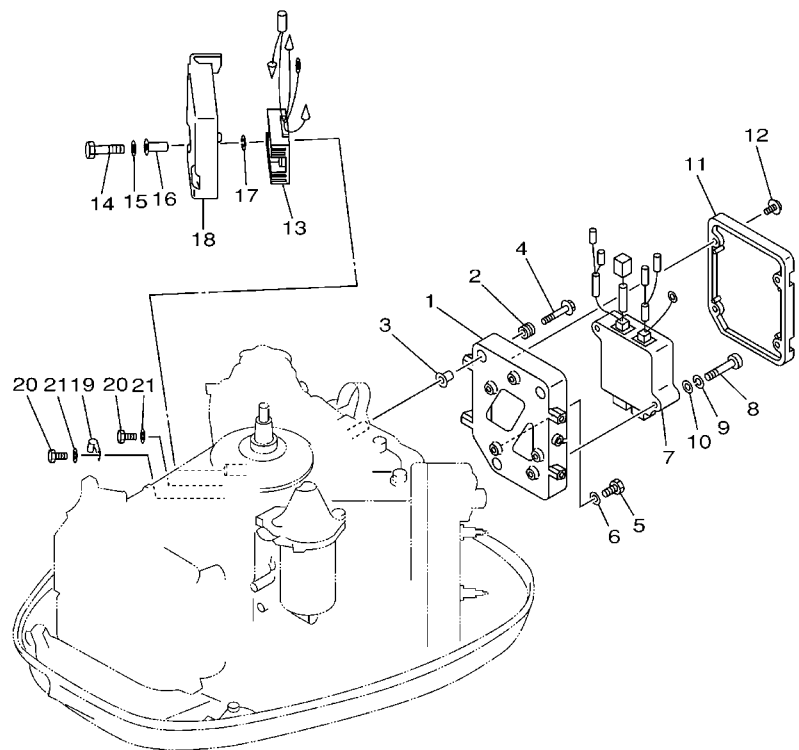

REF. NO.	PART NO. CODIGO Nº	DESCRIPTION DESCRIPCION	6E58	6F38		REMARKS OBSERVACIONES
1	6N7-85542-01-1S	BRACKET SOPORTE	1	1		
2	6A0-82317-00	DAMPER, IGNITION COIL AMORTIGUADOR BOBINA ENCENDIDO	3	3		
3	90387-06119	COLLAR ESPACIADOR	3	3		
4	90119-06M59	BOLT, WITH WASHER TORNILLO CON ARANDELA	3	3		
5	97095-06012	BOLT PERNO	1	1		
6	92995-06600	WASHER ARANDELA	1	1		
7	6E5-85540-00	C.D.I. UNIT ASSY UNIDAD C.D.I. COMPLETA	1	1		
8	97880-06040	SCREW, PAN HEAD TORNILLO DE CABEZA CON PLANA	2	2		
9	92990-06100	WASHER, SPRING ARANDELA PLANA	2	2		
10	92990-06600	WASHER, PLATE ARANDELA PLANA	2	2		
11	6N7-85537-00	COVER CUBIERTA	1	1		
12	90159-06M11	SCREW, WITH WASHER TORNILLO CON VALONA	4	4		
13	6H0-81960-00	RECTIFIER & REGULATOR ASSY RECTIFICADOR Y REGULADOR	1	1		
14	97013-06045	BOLT PERNO	2	2		
15	92903-06600	WASHER, PLATE RONDANA SENCILLA	2	2		
16	90387-06M77	COLLAR ESPACIADOR	2	2		
17	90201-06M05	WASHER, PLATE ARANDELA PLANA	2	2		
18	6E5-81961-00	COVER CUBIERTA	1	1		
19	90465-06M86	CLAMP BRIDA	1	1		
20	97095-06012	BOLT PERNO	2	2		
21	92995-06600	WASHER ARANDELA	2	2		



6E50010-0091

FIG. 10 ELECTRICAL 2

EQUIPO ELECTRICO 2

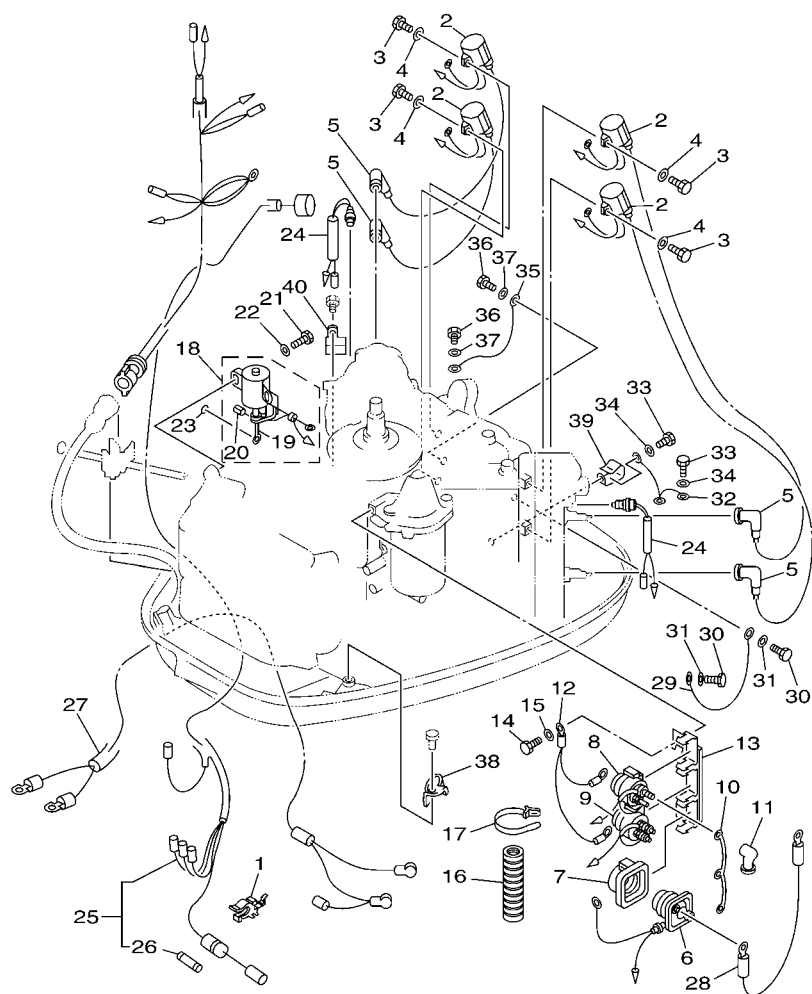

FWD
6E57200-F100

REF. NO.	PART NO. CODIGO Nº	DESCRIPTION DESCRIPCION	6E58	6F38	REMARKS OBSERVACIONES
1	6G5-82152-00	HOLDER, FUSE PORTA-FUSIBLES	1	1	
2	6R3-85570-01	IGNITION COIL ASSY BOBINA DE IGNICION COMPLETO	4	4	
3	97095-06020	BOLT PERNO	4	4	
4	92995-06600	WASHER ARANDELA	4	4	
5	663-82370-01	PLUG CAP ASSY TAPON DE BUJIA COMPLT	4	4	
6	61A-81941-00	STARTER RELAY ASSY RELE DE ARRANQUE	1	1	
7	689-81952-10	HOLDER, RELAY SOSTEN DE RELE	1	1	
8	6E5-81950-00	RELAY ASSY RELE COMPLETO	1	1	
9	6E5-8195A-00	RELAY ASSY RELE COMPLETO	1	1	
10	6G5-87149-10	CONNECTOR CONECTOR	1	1	
11	6G5-82119-00	COVER, LEAD WIRE CUBIERTA DE CABLE CONDUCTOR	2	2	
12	6E5-82116-00	WIRE, MINUS LEAD CABLE CONDUCTOR NEGATIVO	1	1	
13	6E5-81948-22	BRACKET SOPORTE	1	1	
14	97095-06016	BOLT PERNO	2	2	
15	92995-06600	WASHER ARANDELA	2	2	
16	6N7-83557-00	TUBE (I.DIA:22MM) ENCHUFE DE ACEITE (I.DIA:22MM)	1	1	
17	90465-13M18	CLAMP BRIDA	1	1	
18	6E5-86110-02	SOLENOID SOLENOIDE	1	1	
19	6E5-86116-01	.WIRE, PULL .ALAMBRE-JALADOR	1	1	
20	91609-30010	.PIN, SPRING .PASADOR DE RESORTE	1	1	
21	97095-06016	BOLT PERNO	2	2	
22	92995-06600	WASHER ARANDELA	2	2	
23	93210-03261	O-RING ANILLO O	1	1	
24	688-82560-10	THERMO SWITCH ASSY INTER. DE TERMO	2	2	
25	6E5-82590-04	WIRE HARNESS ASSY CONJUNTO DE CABLES	1	1	
26	663-82151-00	.FUSE (12V-20A) .FUSIBLE (12V-20A)	1	1	
27	6E5-82105-12	WIRE HARNESS ARNES DE CABLES	1	1	

FIG. 10 ELECTRICAL 2

EQUIPO ELECTRICO 2

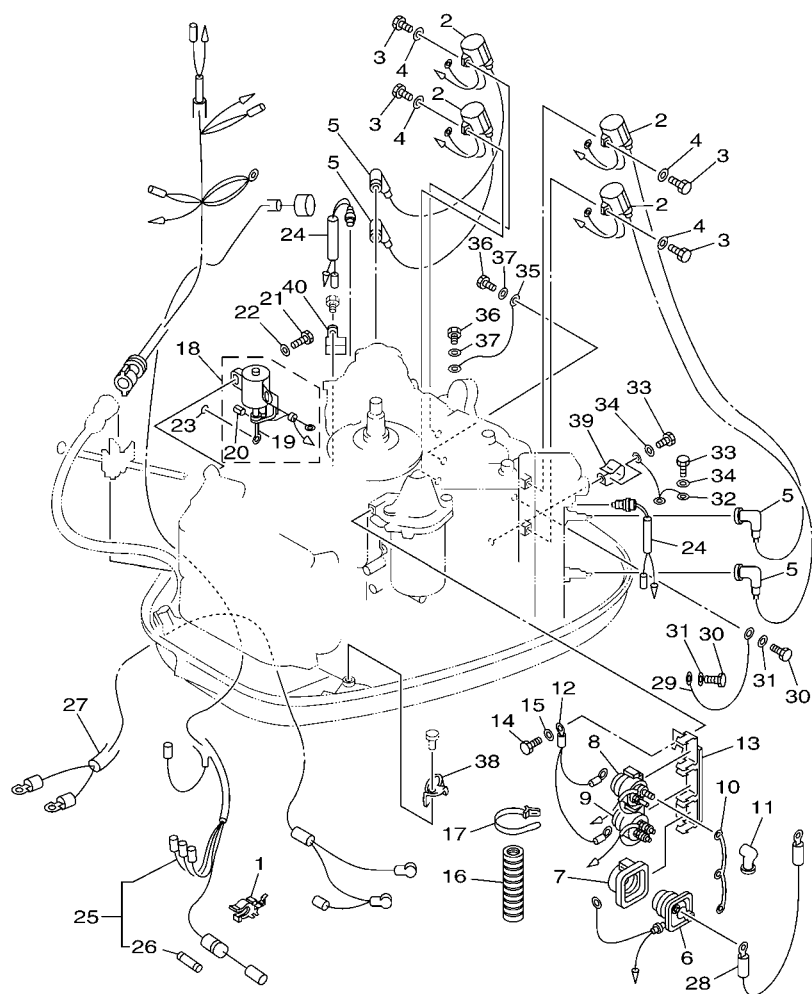

6E57200-F100

REF. NO.	PART NO. CODIGO Nº	DESCRIPTION DESCRIPCION	6E58	6F38		REMARKS OBSERVACIONES
28	6E5-82117-01	WIRE, LEAD CABLE CONDUCTOR	1	1		
29	6R3-82519-00	WIRE, EARTH LEAD CABLE CONDUCTOR A TIERRA	1	1		
30	97095-06012	BOLT PERNO	2	2		
31	92995-06600	WASHER ARANDELA	2	2		
32	6E5-82531-10	WIRE, LEAD CABLE CONDUCTOR	1	1		
33	97095-06012	BOLT PERNO	2	2		
34	92995-06600	WASHER ARANDELA	2	2		
35	662-82519-00	WIRE, EARTH LEAD CABLE CONDUCTOR A TIERRA	1	1		
36	97095-06012	BOLT PERNO	2	2		
37	92995-06600	WASHER ARANDELA	2	2		
38	90465-12M25	CLAMP BRIDA	1	1		
39	90465-05M87	CLAMP BRIDA	1	1		
40	90465-08M89	CLAMP BRIDA	1	1		

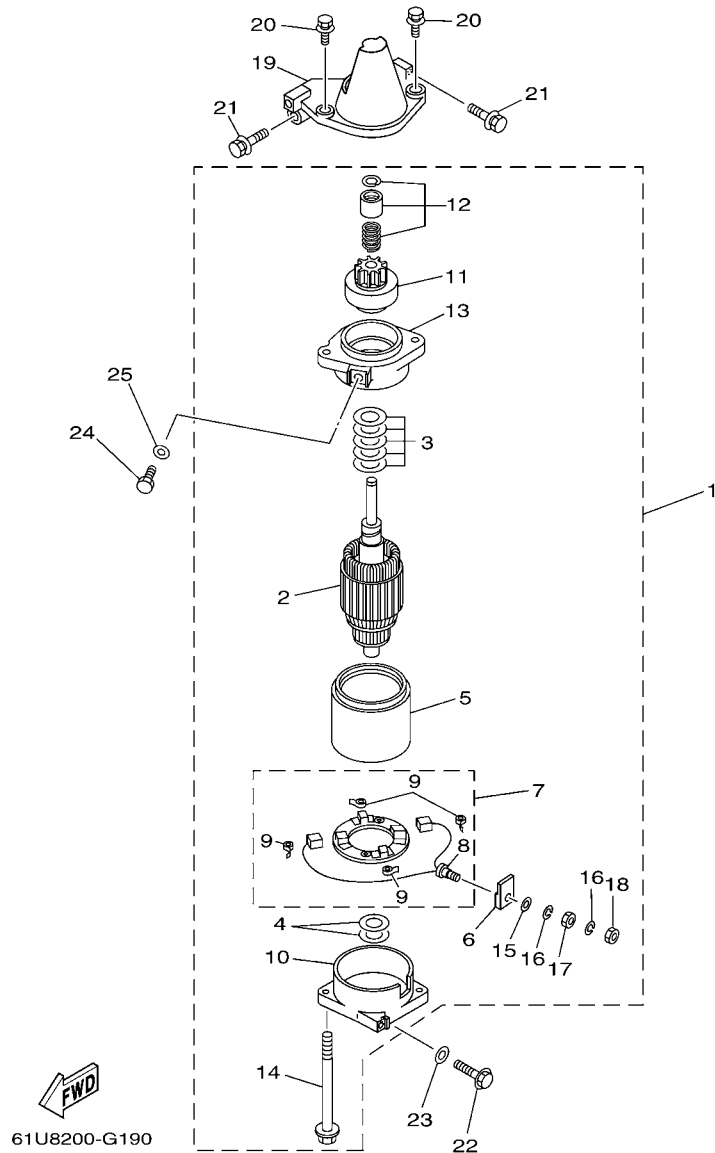

FIG. 11 STARTING MOTOR

MOTOR DE ARRANQUE

REF. NO.	PART NO. CODIGO Nº	DESCRIPTION DESCRIPCION	6E58	6F38		REMARKS OBSERVACIONES
1	6N7-81800-10	STARTING MOTOR ASSY MOTOR DE ARRANQUE COMPLETO	1	1		
2	6N7-81850-10	.ARMATURE ASSY .INDUCIDO COMPLETO	1	1		
3	61A-81809-00	.WASHER KIT .JUEGO DE ARANDELA	1	1		
4	61A-81824-00	.WASHER 2 .ARANDELA 2	2	2		
5	6N7-81810-00	.STATOR ASSY .ESTATOR COMPLETO	1	1		
6	6K7-8182G-10	.BUSH, TERMINAL .BUJE DE TERMINAL	1	1		
7	6N7-81840-00	.BRUSH HOLDER ASSY .SOSTEN DE ESCOBILLA COMPLETO	1	1		
8	6N7-81801-00	..BRUSH SET ..JUEGO DE ESCOBILLA	1	1		
9	6N7-81813-00	..SPRING, BRUSH ..RESORTE DE ESCOBILLA	4	4		
10	6N7-81820-10	.REAR BRACKET ASSY .CUBIERTA TRASERA COMPL	1	1		
11	6N7-81807-00	.GEAR ASSY, STARTING MOTOR .PINON CONJUNTO	1	1		
12	6N7-81857-00	.RETAINER .SEGURO	1	1		
13	6N7-81830-00	.FRONT BRACKET ASSY .SOPORTE DELANTERO COMPLETO	1	1		
14	6K7-81826-11	.BOLT .PERNO	2	2		
15	6E5-8182E-10	.WASHER .RONDANA	1	1		
16	6E5-8182F-10	.WASHER .RONDANA	2	2		
17	6E5-8182A-10	.NUT .TUERCA	1	1		
18	6E5-8182K-10	.NUT .TUERCA	1	1		
19	6E5-81822-02-98	BRACKET, STARTING MOTOR SOPORTE DE MOTOR DE ARRANQUE	1	1		
20	90119-08M76	BOLT, WITH WASHER TORNILLO CON ARANDELA	2	2		
21	90119-08M77	BOLT, WITH WASHER TORNILLO CON ARANDELA	2	2		
22	90119-08M57	BOLT, WITH WASHER TORNILLO CON ARANDELA	1	1		
23	92990-08600	WASHER, PLATE ARANDELA PLANA	1	1		
24	97095-08016	BOLT PERNO	1	1		
25	92995-08600	WASHER ARANDELA	1	1		

FIG. 12 BOTTOM COWLING

CUBIERTA INFERIOR

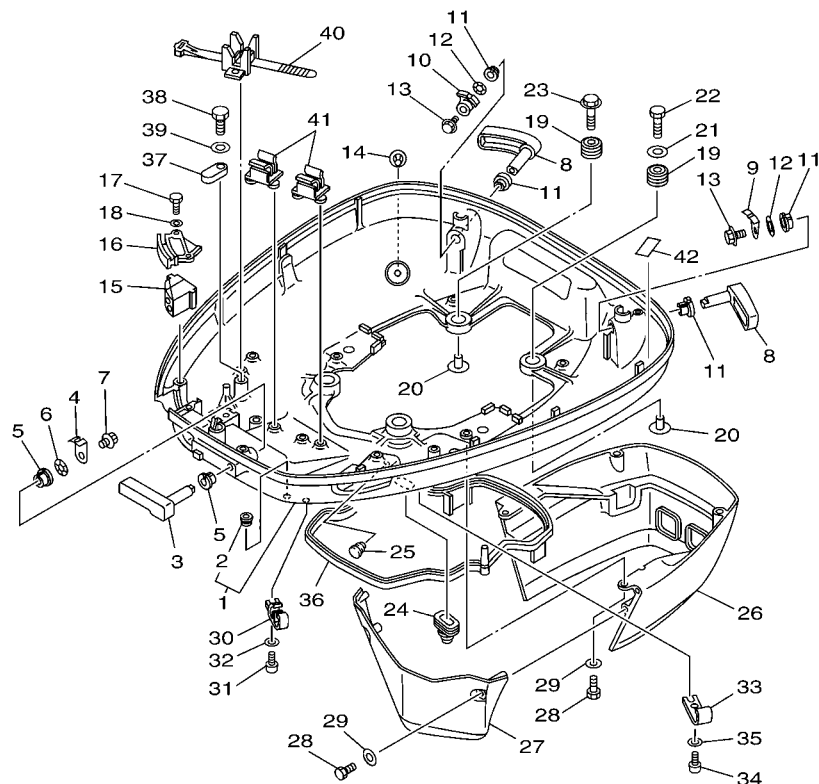

6E57200-F120

REF. NO.	PART NO. CODIGO Nº	DESCRIPTION DESCRIPCION	6E58	6F38	REMARKS OBSERVACIONES
1	6E5-W4271-05-4D	COWLING, BOTTOM CUBIERTA INFERIOR	1	1	
2	6H4-42748-00	.GROMMET .TAPON	1	1	
3	688-42815-01-4D	LEVER, CLAMP PALANCA ABRAZADERA	1	1	
4	688-42816-00	LEVER, CLAMP PALANCA ABRAZADERA	1	1	
5	90386-13M38	BUSH BUJE	2	2	
6	90206-13M10	WASHER, WAVE ARANDELA ONDULADA	1	1	
7	90119-06M09	BOLT, WITH WASHER TORNILLO CON ARANDELA	1	1	
8	6E5-42817-01-4D	LEVER, CLAMP PALANCA ABRAZADERA	2	2	
9	6G5-42816-00	LEVER, CLAMP PALANCA ABRAZADERA	1	1	
10	6E5-42816-01	LEVER, CLAMP PALANCA ABRAZADERA	1	1	
11	90386-13M38	BUSH BUJE	4	4	
12	90206-13M10	WASHER, WAVE ARANDELA ONDULADA	2	2	
13	90119-06M09	BOLT, WITH WASHER TORNILLO CON ARANDELA	2	2	
14	6E5-44391-00	NIPPLE, HOSE NIPLE MANGUERA	1	1	
15	6E5-42725-00	GROMMET TAPON	1	1	
16	6E5-42738-01-5B	PLATE, FITTING PLACA DE AJUSTE	1	1	
17	97095-06016	BOLT PERNO	2	2	
18	92995-06600	WASHER ARANDELA	2	2	
19	90480-22M15	GROMMET TAPON	4	4	
20	90387-08M37	COLLAR ESPACIADOR	4	4	
21	90201-08M54	WASHER, PLATE ARANDELA PLANA	1	1	
22	97075-08035	BOLT PERNO	1	1	
23	90119-08M22	BOLT, WITH WASHER TORNILLO CON ARANDELA	3	3	
24	688-42726-10	GROMMET TAPON	1	1	
25	90480-10M36	GROMMET TAPON	1	1	
26	6E5-42741-01-4D	APRON MANDIL	1	1	
27	6E5-42771-01-4D	APRON MANDIL	1	1	

FIG. 12 BOTTOM COWLING

CUBIERTA INFERIOR

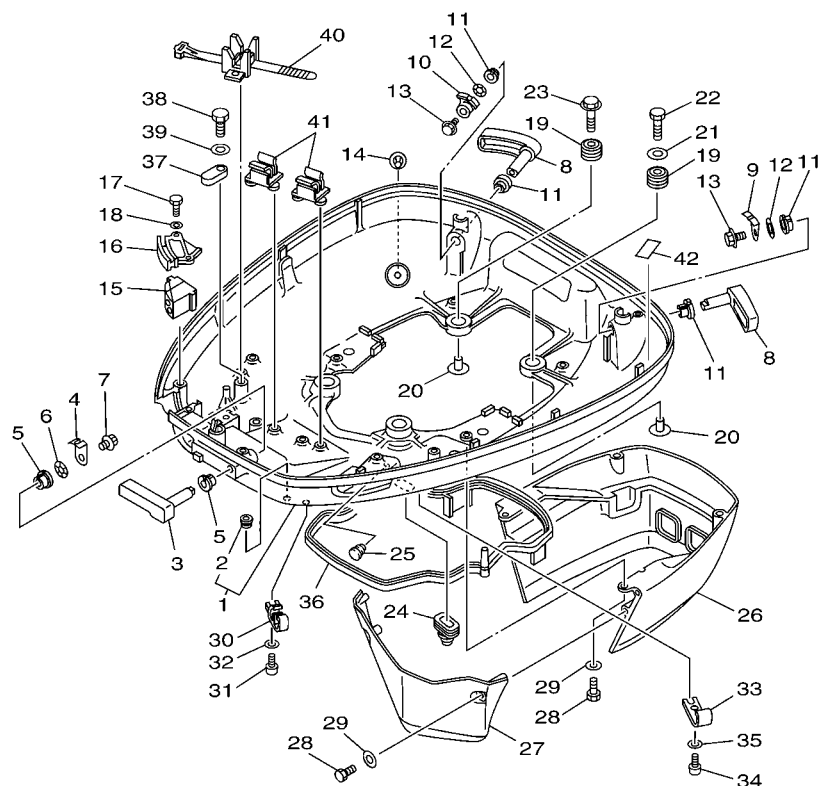

FWD
6E57200-F120

REF. NO.	PART NO. CODIGO Nº	DESCRIPTION DESCRIPCION	6E58	6F38		REMARKS OBSERVACIONES
28	97095-06020	BOLT PERNO	6	6		
29	92995-06600	WASHER ARANDELA	6	6		
30	6E5-24367-01	CLAMP, FUEL PIPE 2 GRAMPA DE TUBO DE COMBUST.2	2	2		
31	90157-06M01	SCREW, PAN HEAD TORNILLO CABEZA CONICA PLANA	2	2		
32	92990-06600	WASHER, PLATE ARANDELA PLANA	2	2		
33	6E5-24367-10	CLAMP, FUEL PIPE 2 GRAMPA DE TUBO DE COMBUST.2	1	1		
34	90157-06M01	SCREW, PAN HEAD TORNILLO CABEZA CONICA PLANA	1	1		
35	92990-06600	WASHER, PLATE ARANDELA PLANA	1	1		
36	6E5-42716-00	RUBBER, SEAL 1 SELLO DE GOMA 1	1	1		
37	6E5-82588-00	PLATE PLACA	1	1		
38	97095-06020	BOLT PERNO	1	1		
39	92995-06600	WASHER ARANDELA	1	1		
40	688-82594-00	CLAMP GRAMPA	1	1		
41	6E5-82594-00	CLAMP GRAMPA	2	2		
42	6G5-42791-00	MARK 1 MARCA 1	1			
	6G5-42791-10	MARK 1 MARCA 1	1			FOR CHN FOR CHN
	6L1-42791-00	MARK 1 MARCA 1		1		
	6K7-42791-00	MARK 1 MARCA 1		1		FOR CHN FOR CHN

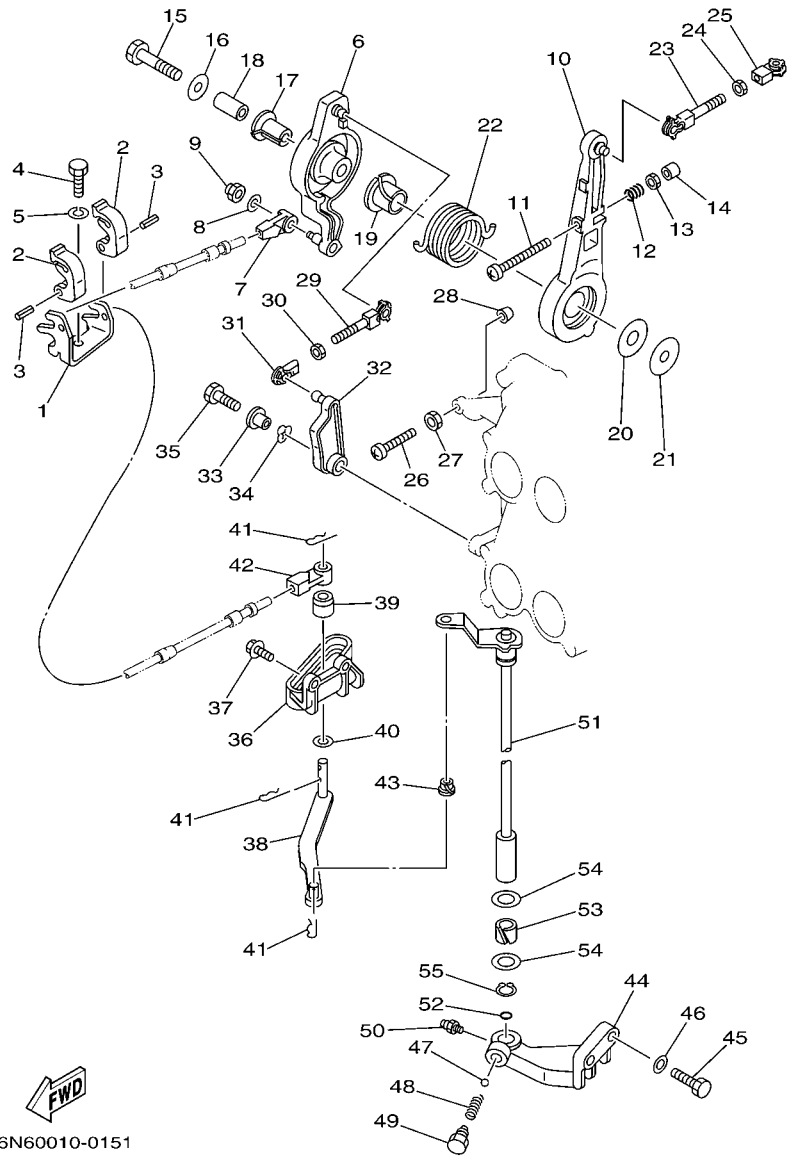

6N60010-0151

FIG. 13 CONTROL

CONTROL

REF. NO.	PART NO. CODIGO Nº	DESCRIPTION DESCRIPCION	6E58	6F38	REMARKS OBSERVACIONES
1	6E5-48531-00	BRACKET, REMOTE CONTROL 1 SOPORTE DE CONTROL REMOTO	1	1	
2	6E5-48538-00	CLAMP, CABLE GRAMPA DE CABLE	2	2	
3	91690-30012	PIN, SPRING PASADOR DE RESORTE	2	2	
4	97095-08020	BOLT PERNO	1	1	
5	92995-08100	WASHER ARANDELA	1	1	
6	6E5-41632-02-1S	LEVER, MAGNETO CONTROL PALANCA DE CONTROL DE MAGNETO	1	1	
7	6E5-48344-00	CABLE END, REMOTE CONTROL BASE CONTROL	1	1	
8	92990-06200	WASHER, PLAIN ARANDELA PLANA	1	1	
9	90185-06M07	NUT, SELF-LOCKING TUERCA AUTOBLOCANTE	1	1	
10	6E5-41631-01-1S	LEVER, MAGNETO CONTROL PALANCA DE CONTROL DE MAGNETO	1	1	
11	90157-06013	SCREW, PAN HEAD TORNILLO CABEZA CONICA PLANA	1	1	
12	90501-16M12	SPRING, COMPRESSION RESORTE DE COMPRESION	1	1	
13	95303-06600	NUT TUERCA	1	1	
14	688-44194-00	CAP TAPA	1	1	
15	97013-08045	BOLT PERNO	1	1	
16	90201-08M23	WASHER, PLATE ARANDELA PLANA	1	1	
17	90386-12089	BUSH BUJE	1	1	
18	90387-08M16	COLLAR ESPACIADOR	1	1	
19	90386-22M13	BUSH BUJE	1	1	
20	90202-12092	WASHER, PLATE ARANDELA DE PLANA	1	1	
21	90201-08M13	WASHER, PLATE ARANDELA PLANA	1	1	
22	90508-29M12	SPRING, TORSION RESORTE DE TORSION	1	1	
23	6E5-41636-01	ROD, MAGNETO CONTROL VARILLA DE CONTROL MAGNETO	1	1	
24	95380-05600	NUT TUERCA	1	1	
25	662-41237-01	JOINT, LINK CONECTOR	1	1	
26	90157-06013	SCREW, PAN HEAD TORNILLO CABEZA CONICA PLANA	1	1	
27	95303-06600	NUT TUERCA	1	1	

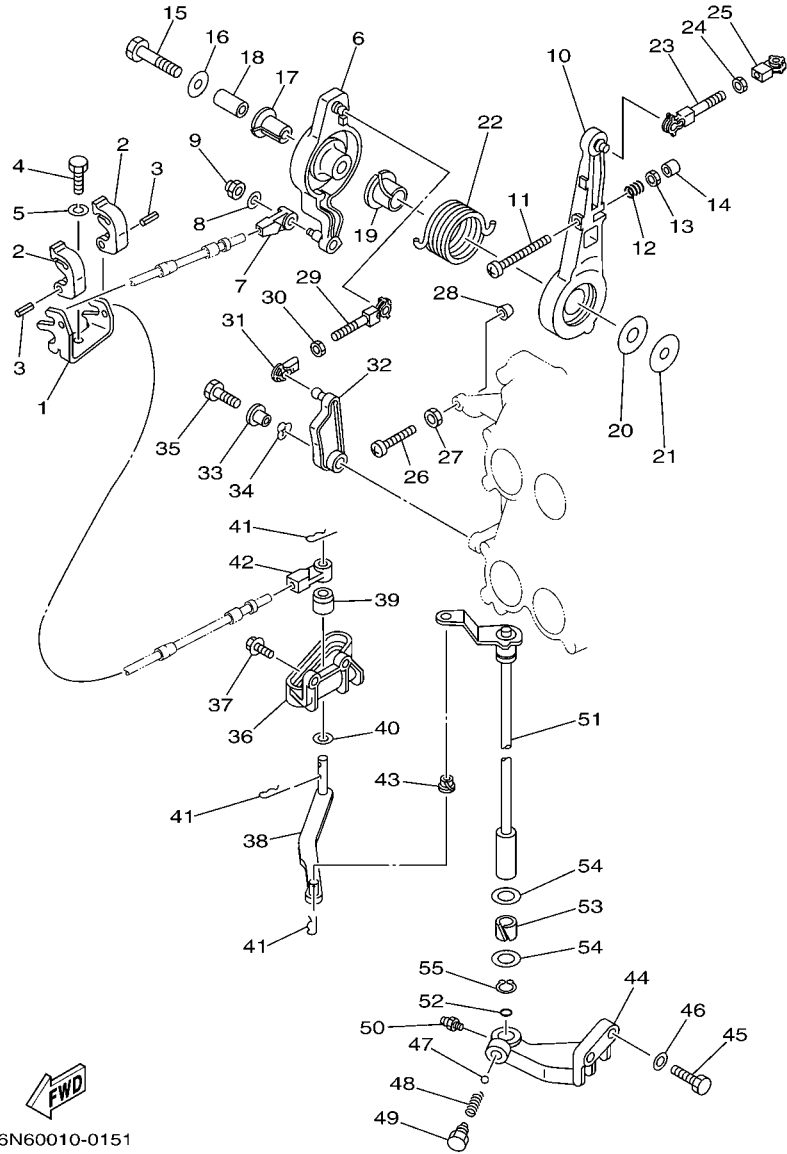

6N60010-0151

FIG. 13 CONTROL

CONTROL

REF. NO.	PART NO. CODIGO Nº	DESCRIPTION DESCRIPCION	6E58	6F38		REMARKS OBSERVACIONES
28	688-44194-00	CAP TAPA	1	1		
29	688-41636-00	ROD, MAGNETO CONTROL VARILLA DE CONTROL MAGNETO	1	1		
30	95380-05600	NUT TUERCA	1	1		
31	662-41237-01	JOINT, LINK CONECTOR	1	1		
32	6E5-41213-00	CAM, ACCEL. LEVA ACELERADOR	1	1		
33	90387-06M29	COLLAR ESPACIADOR	1	1		
34	90206-10M04	WASHER, WAVE ARANDELA ONDULADA	1	1		
35	97095-06025	BOLT PERNO	1	1		
36	6E5-44117-00-1S	BRACKET SOPORTE	1	1		
37	90119-06MA2	BOLT, WITH WASHER TORNILLO CON ARANDELA	2	2		
38	68F-44121-00	LEVER, SHIFT ROD PALANCA VARILLA CAMBIOS	1	1		
39	6E5-44122-00	BUSHING, SHIFT ROD LEVER BUJE PALANCA VARILLA DE CAMBIO	1	1		
40	90202-08M20	WASHER, PLATE ARANDELA DE PLANA	1	1		
41	90468-18008	CLIP PRESILLA	3	3		
42	6E5-48344-00	CABLE END, REMOTE CONTROL BASE CONTROL	1	1		
43	90386-06M12	BUSH BUJE	1	1		
44	6E5-44118-01-94	BRACKET SOPORTE	1	1		
45	97013-08030	BOLT PERNO	2	2		
46	92903-08600	WASHER, PLATE RONDANA SENCILLA	2	2		
47	93501-04M02	BALL BOLA	1	1		
48	90501-12082	SPRING, COMPRESSION RESORTE DE COMPRESION	1	1		
49	648-42715-00	BUSHING BUJE	1	1		
50	93700-06M03	NIPPLE, GREASE BOQUILLA DE ENGRASAR	1	1		
51	6E5-44120-03	HANDLE GEAR SHIFT ASSY MANIJA DE CAMBIO COMPL	1	1		L(20.3")
	6E5-44120-23	HANDLE GEAR SHIFT ASSY MANIJA DE CAMBIO COMPL	1	1		L(20.3") X(25.3")
52	93210-09165	O-RING ANILLO O	1	1		
53	90386-16M66	BUSH BUJE	1	1		

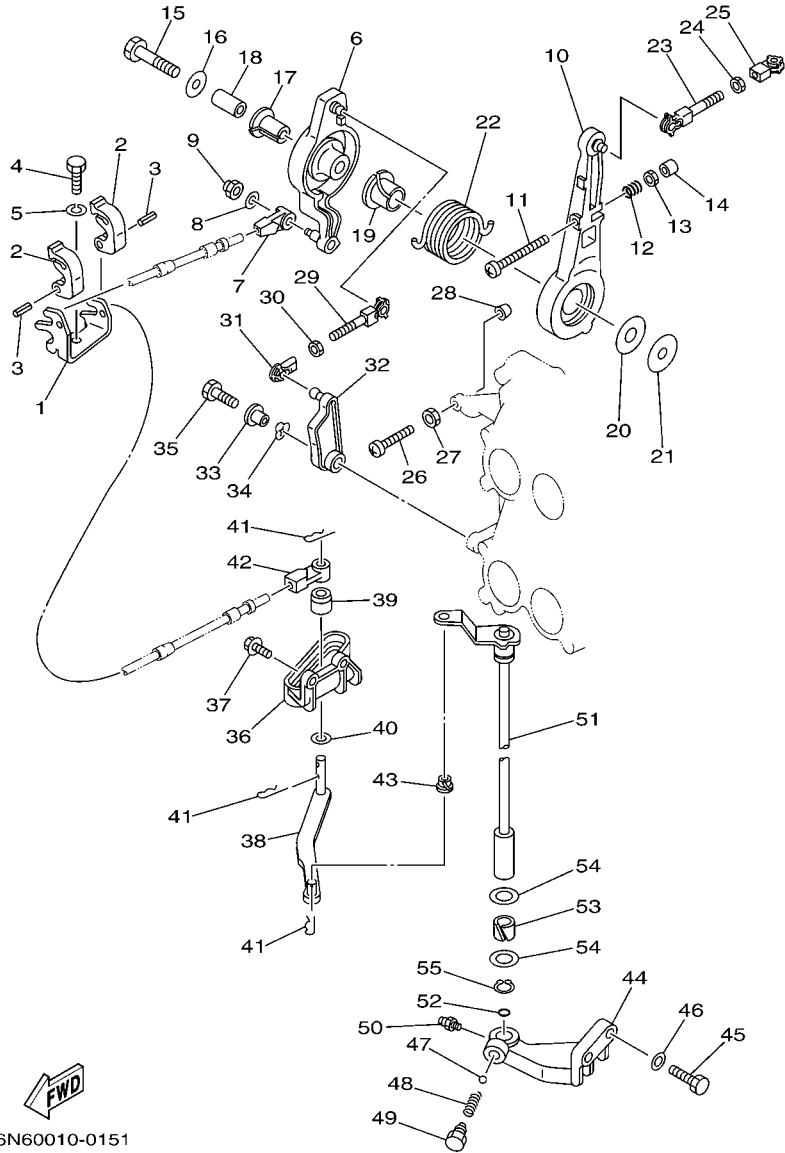

6N60010-0151

FIG. 13 CONTROL

CONTROL

REF. NO.	PART NO. CODIGO Nº	DESCRIPTION DESCRIPCION	6E58	6F38			REMARKS OBSERVACIONES
54	90202-16061	WASHER, PLATE ARANDELA DE PLANA	2	2			
55	93410-16006	CIRCLIP SEGURO	1	1			

FIG. 14 BRACKET 1

SOPORTE 1

REF. NO.	PART NO. CODIGO Nº	DESCRIPTION DESCRIPCION	6E68	6F38	REMARKS OBSERVACIONES
1	64E-43111-02-8D	BRACKET, CLAMP 1 SOPORTE DE LA ABRAZADERA 1	1	1	
2	6G5-45251-02	ANODE CATODE	1	1	
3	6G5-44526-00	PLATE PLACA 1	2	2	
4	97095-06030	BOLT PERNO	4	4	
5	92995-06100	WASHER, SPRING ARANDELA	4	4	
6	6E5-82148-00	WIRE, LEAD 4 CABLE CONDUCTOR 4	1	1	
7	97095-06010	BOLT PERNO	1	1	
8	92995-06600	WASHER ARANDELA	1	1	
9	64E-43112-02-8D	BRACKET, CLAMP 2 SOPORTE DE LA ABRAZADERA 2	1	1	
10	6E5-82148-00	WIRE, LEAD 4 CABLE CONDUCTOR 4	1	1	
11	97885-06012	SCREW, PAN HEAD TORNILLO A MUESCA	1	1	
12	92995-06600	WASHER ARANDELA	1	1	
13	93700-06M03	NIPPLE, GREASE BOQUILLA DE ENGRASAR	1	1	
14	663-45119-00	CAP, GREASE NIPPLE TAPA DE GRASERA	1	1	AP AP
15	64E-43131-01	BOLT, CLAMP BRACKET TORNILLO DE ABRAZADERA DEL SOP	1	1	
16	97095-08020	BOLT PERNO	1	1	
17	92995-08100	WASHER ARANDELA	1	1	
18	90386-25M31	BUSH BUJE	2	2	
19	90201-26M59	WASHER, PLATE ARANDELA PLANA	2	2	
20	90185-22M11	NUT, SELF-LOCKING TUERCA AUTOBLOCANTE	1	1	
21	90465-11M10	CLAMP BRIDA	1	1	
22	64E-43311-10-8D	BRACKET, SWIVEL 1 SOPORTE GIRATORIO 1	1	1	L(20.3") L(20.3")
	64E-43311-20-8D	BRACKET, SWIVEL 1 SOPORTE GIRATORIO 1	1	1	X(25.3") X(25.3")
23	90465-08M63	CLAMP BRIDA	1	1	
24	93700-06M03	NIPPLE, GREASE BOQUILLA DE ENGRASAR	5	5	
25	663-45119-00	CAP, GREASE NIPPLE TAPA DE GRASERA	5	5	AP AP
26	6E5-82147-00	WIRE, LEAD 4 CABLE CONDUCTOR 4	1	1	L(20.3") L(20.3")

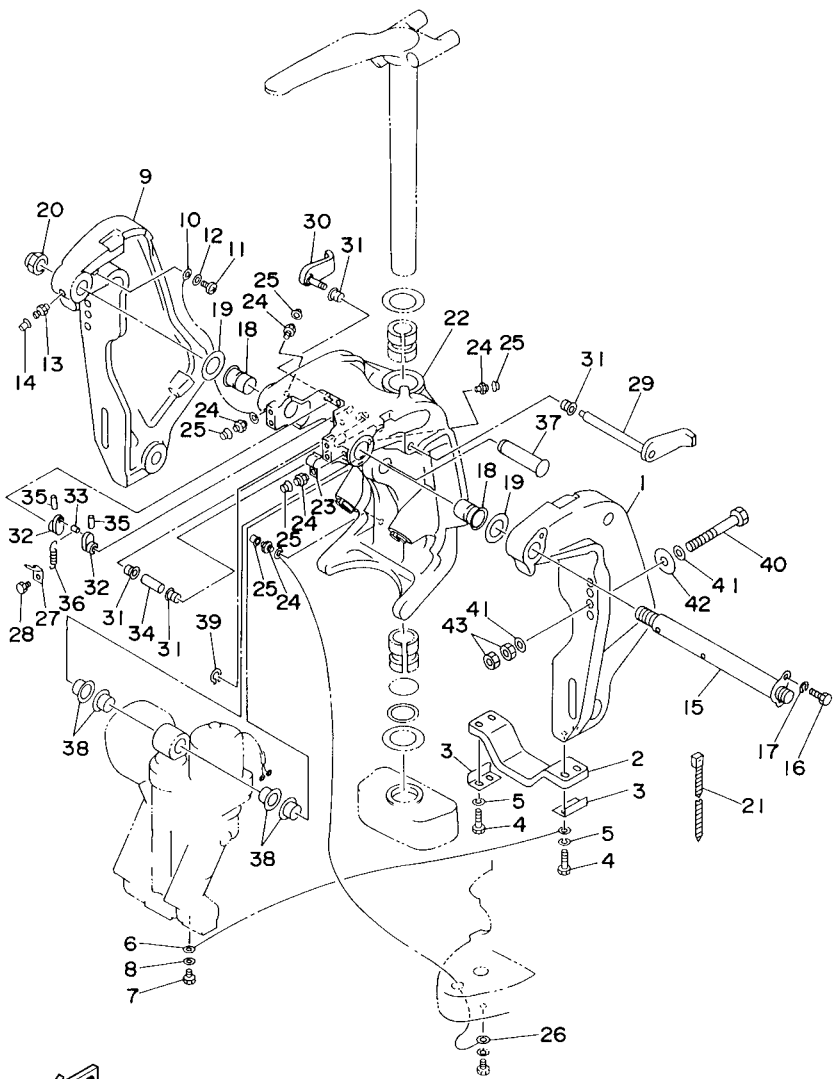

6N60010-7160

FIG. 14 BRACKET 1

SOPORTE 1

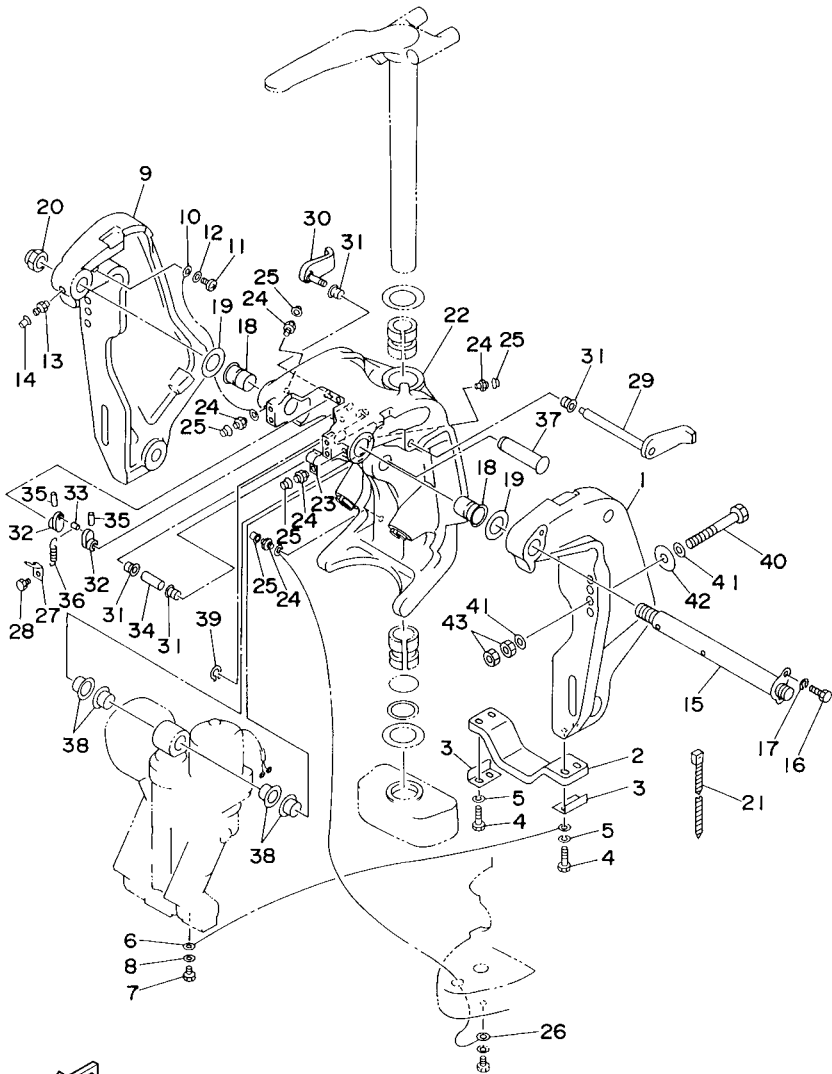

FWD
6N60010-7160

REF. NO.	PART NO. CODIGO Nº	DESCRIPTION DESCRIPCION	6E58	6F38	REMARKS OBSERVACIONES
26	6E5-82147-20	WIRE, LEAD 4 CABLE CONDUCTOR 4	1	1	X(25.3") X(25.3")
27	6G5-43144-00	HOOK, SPRING GANCHO	1	1	
28	97095-06010	BOLT PERNO	1	1	
29	6G5-43181-02	LEVER, TILT STOP PALANCA TOPE INCLINACION	1	1	
30	6G5-43185-02	LEVER, TILT STOP PALANCA TOPE INCLINACION	1	1	
31	90386-10M16	BUSH BUJE	4	4	
32	6G5-43148-00	COLLAR, DISTANCE COLLAR	2	2	
33	90249-06M19	PIN PASADOR	1	1	
34	90387-10M05	COLLAR ESPACIADOR	1	1	
35	91690-30020	PIN, SPRING PASADOR DE RESORTE	2	2	
36	90506-14M24	SPRING, TENSION RESORTE DE TENSION	1	1	
37	64E-43126-00	PIN, UPPER SHOCK MOUNT PASADOR DE AMORTIGUADOR SUPERIOR	1	1	
38	90386-22M98	BUSH BUJE	4	4	
39	93410-22M11	CIRCLIP SEGURO	1	1	
40	90101-12M03	BOLT (L:115MM) TORNILLO (L:115MM)	4	4	
41	90201-13M01	WASHER, PLATE ARANDELA PLANA	8	8	
42	90201-12M05	WASHER, PLATE ARANDELA PLANA	4	4	
43	95380-12600	NUT TUERCA	8	8	

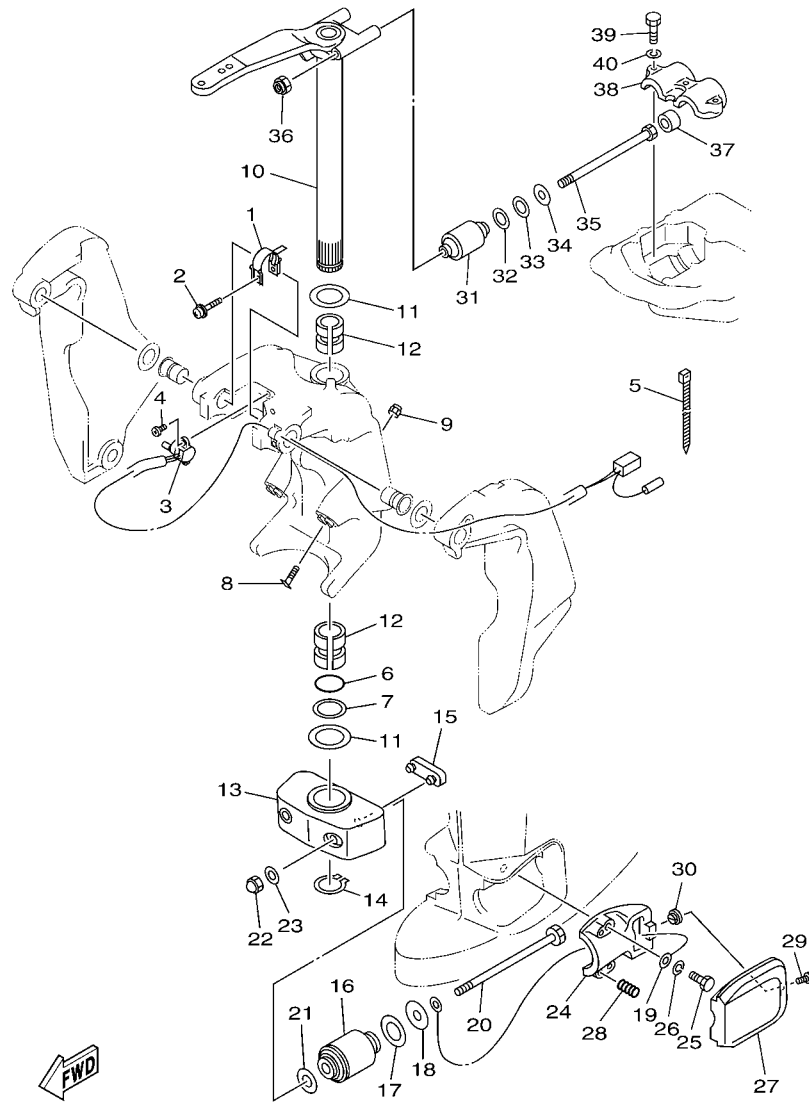

6E58200-G150

FIG. 15 BRACKET 2

SOPORTE 2

REF. NO.	PART NO. CODIGO Nº	DESCRIPTION DESCRIPCION	6E58	6F38	REMARKS OBSERVACIONES
1	64E-43139-10	CAM, TRIM SENDER LEVA TRANSMISOR DE INCLINDOR	1	1	
2	97980-05230	SCREW, WITH WASHER TORNILLO, CON ARANDELA	1	1	
3	64E-83672-02	TRIM SENDER TRANSMISOR DE INCLINADOR	1	1	
4	97885-06016	SCREW, PAN HEAD TORNILLO A MUESCA	2	2	
5	90465-11M10	CLAMP BRIDA	3	3	
6	93210-37MH7	O-RING ANILLO O	1	1	
7	90202-40M47	WASHER, PLATE ARANDELA DE PLANA	1	1	
8	61A-43376-00	BOLT, THRUST RECEIVER TORNILLO RECEPTOR	2	2	
9	95780-10300	NUT, FLANGE TUERCA	2	2	
10	6E5-42510-05-8D	STEERING BRACKET ASSY SOPORTE DIRECCION COMPL.	1	1	L(20.3") L(20.3")
	6E5-42510-25-8D	STEERING BRACKET ASSY SOPORTE DIRECCION COMPL.	1	1	X(25.3") X(25.3")
11	90201-38M60	WASHER, PLATE ARANDELA PLANA	2	2	
12	90386-38M32	BUSH BUJE	2	2	
13	6G5-44551-01-8D	HOUSING, LOWER MOUNT RUBBER CAJA AMORTIGUADOR INFERIOR HU	1	1	
14	93410-37M04	CIRCLIP SEGURO	1	1	
15	6E5-44575-00	DAMPER, LOWER MOUNT RUBBER AMORTIGUADOR INFERIOR	1	1	
16	6E5-44555-00-94	MOUNT DAMPER, LOWER SIDE AMORTIGUADOR DE HULE LADO INFE	2	2	
17	90202-32M19	WASHER, PLATE ARANDELA DE PLANA	2	2	
18	90201-16M55	WASHER, PLATE ARANDELA PLANA	2	2	
19	6E5-82149-00	WIRE, LEAD 3 CABLE CONDUCTOR 3	1	1	
20	90109-14M34	BOLT PERNO	2	2	
21	90201-15M58	WASHER, PLATE ARANDELA PLANA	2	2	
22	95380-14800	NUT TUERCA	2	2	
23	92995-14600	WASHER ARANDELA	2	2	
24	6E5-44552-01-94	HOUSING, LOWER MOUNT RUBBER CAJA AMORTIGUADOR INFERIOR HU	2	2	
25	97095-10045	BOLT PERNO	4	4	
26	92995-10100	WASHER ARANDELA	4	4	

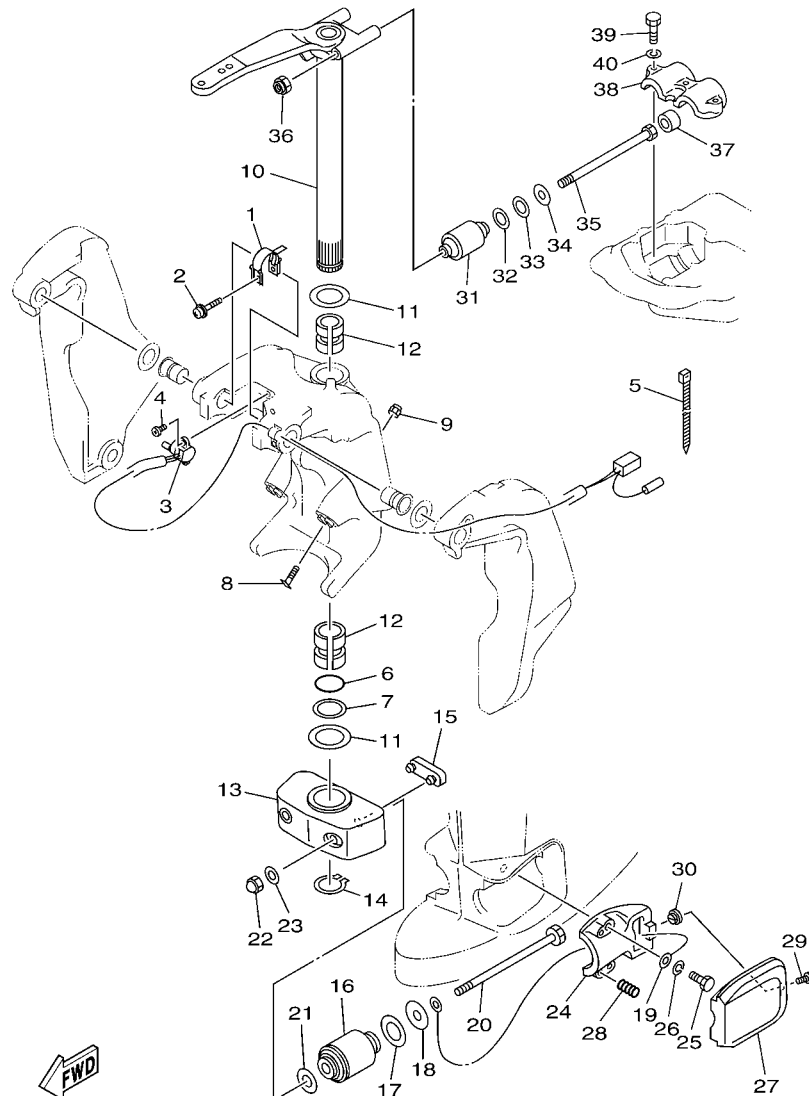

6E58200-G150

FIG. 15 BRACKET 2

SOPORTE 2

REF. NO.	PART NO. CODIGO Nº	DESCRIPTION DESCRIPCION	6E58	6F38	REMARKS OBSERVACIONES
27	6E5-44553-01-8D	COVER, LOWER MOUNT CUBIERTA, AMORTIGUADOR INFERIOR	2	2	
28	90501-16M28	SPRING, COMPRESSION RESORTE DE COMPRESION	4	4	
29	97885-06016	SCREW, PAN HEAD TORNILLO A MUESCA	2	2	
30	90179-06066	NUT TUERCA	2	2	
31	6E5-44514-00-94	MOUNT DAMPER, UPPER SIDE AMORTIGUADOR LADO SUPERIOR	2	2	
32	90201-26M57	WASHER, PLATE ARANDELA PLANA	2	2	
33	90202-26M18	WASHER, PLATE ARANDELA DE PLANA	2	2	
34	90201-14M56	WASHER, PLATE ARANDELA PLANA	2	2	
35	90109-12007	BOLT PERNO	2	2	
36	90185-12M12	NUT, SELF-LOCKING TUERCA AUTOBLOCANTE	2	2	
37	663-44575-00	DAMPER, LOWER MOUNT RUBBER AMORTIGUADOR INFERIOR	2	2	
38	6E5-44511-00-5B	COVER, UPPER MOUNT CUBIERTA AMORTIGUADOR SUPERIOR	1	1	
39	97095-10045	BOLT PERNO	3	3	
40	92995-10100	WASHER ARANDELA	3	3	

FIG. 16 POWER TRIM & TILT ASSY 1 COMPONER Y PODER VARILLA 1

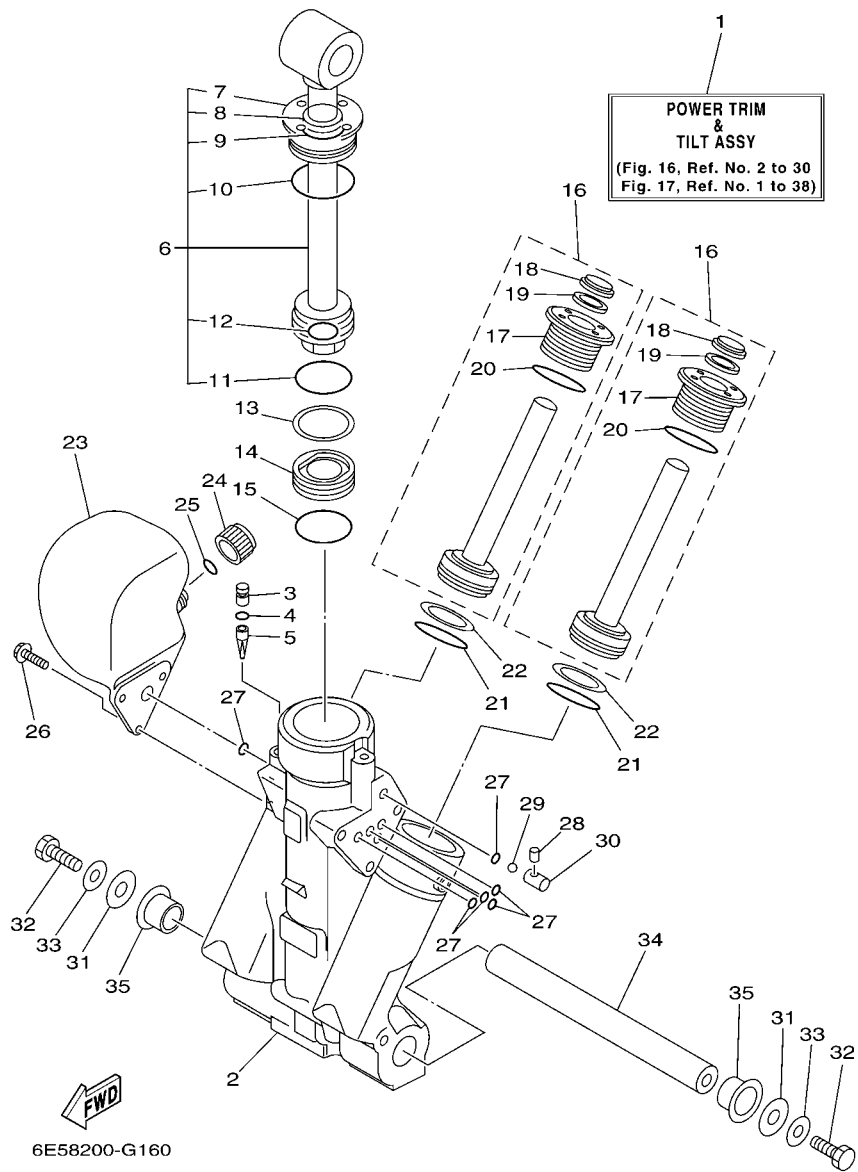

REF. NO.	PART NO. CODIGO Nº	DESCRIPTION DESCRIPCION	6E58	6F38		REMARKS OBSERVACIONES
1	64E-43800-04-4D	POWER TRIM & TILT ASSY ELEVADOR HIDRAULICO COMPL.	1	1		
2	64E-43825-02	HOUSING, TRIM & TILT CAJA INCLINACION Y ADRNO	1	1		
3	64E-4388J-00	PLUG 2 TAPON 2	1	1		
4	93210-10M74	O-RING ANILLO O	1	1		
5	64E-43817-00	FILTER 2 FILTRO 2	1	1		
6	64E-43810-01	TILT PISTON SUB ASSY ELEVADOR SUB-PISTON COMPL.	1	1		
7	64E-43811-01	.SCREW, CYLINDER END .TORNILLO CILINDRO EXTREMO	1	1		
8	64E-43898-00	.SEAL ,DUST 2 .SELLO ANTIPOLVO	1	1		
9	64E-43867-00	.O-RING .ANILLO EN O 7	1	1		
10	64E-43866-00	.O-RING .ANILLO EN O 6	1	1		
11	6E5-43862-00	.O-RING .ANILLO EN O 2	1	1		
12	64E-43883-00	.O-RING .ANILLO EN O 10	1	1		
13	6E5-43872-00	RING, BACK UP ANILLO	1	1		
14	6E5-43814-02	PISTON, FREE PISTON LIBRE	1	1		
15	6E5-43862-00	O-RING ANILLO EN O 2	1	1		
16	64E-43820-01	TRIM PISTON SUB ASSY ELEVADOR PISTON COMPL.	2	2		
17	64E-43821-01	.SCREW, TRIM CYLINDER END .TORNILLO CILINDURO EXTREMO	1	1		
18	64E-43822-00	.SEAL, TRIM DUST .SELLO DE POLVO	1	1		
19	64E-4384J-00	.SEAL, TRIM DOWN .SELLO	1	1		
20	6G5-43864-00	.O-RING .ANILLO EN O 4	1	1		
21	6E5-43864-00	O-RING ANILLO EN O 4	2	2		
22	6E5-43874-01	RING, BACK UP ANILLO	2	2		
23	64E-43828-00	BODY, RESERVOIR CUERPO DEPOSITO	1	1		
24	64E-43829-00	PLUG, RESERVOIR TAPON DEPOSITO	1	1		
25	64E-43897-00	O-RING ANILLO EN O	1	1		
26	64E-4388E-00	BOLT ,SCREW (L:14MM) PERNO (L:14MM)	3	3		
27	64E-43869-00	O-RING ANILLO EN O 9	6	6		

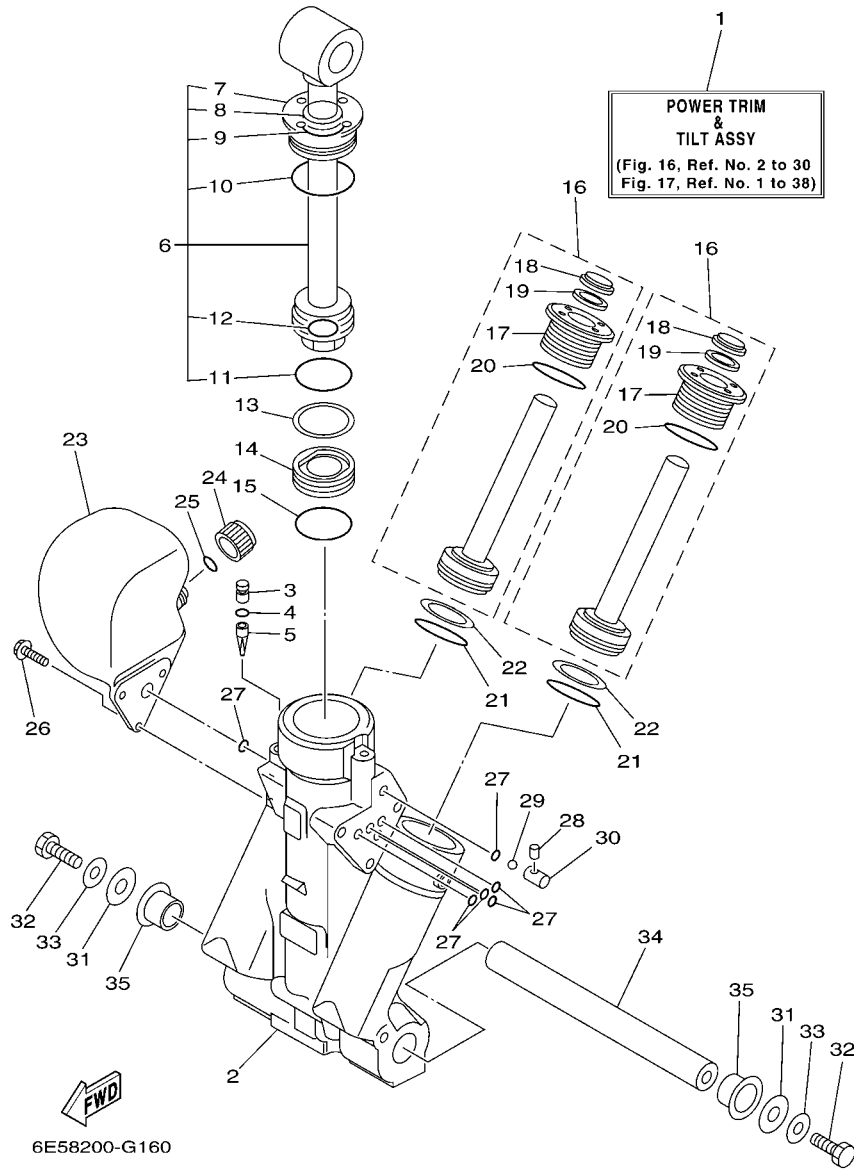
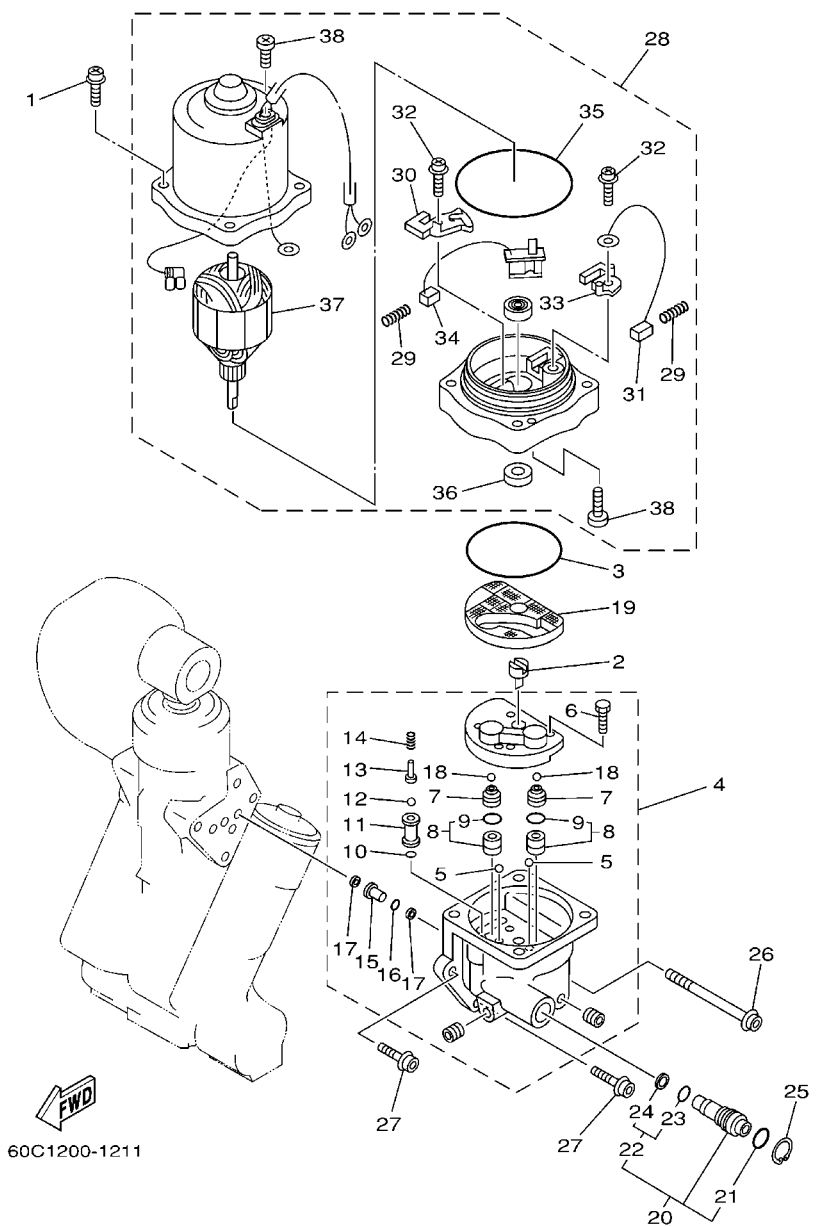

FIG. 16 POWER TRIM & TILT ASSY 1 COMPONER Y PODER VARILLA 1

REF. NO.	PART NO. CODIGO N°	DESCRIPTION DESCRIPCION	6E58	6F38	REMARKS OBSERVACIONES
28	64E-4381G-00	PIN PASADOR 1	1	1	
29	6E5-43858-00	BALL ESFERA	1	1	
30	64E-4382G-00	VALVE, SEAT JUEGO ASIENTO VALVULA	1	1	
31	90201-10060	WASHER, PLATE ARANDELA PLANA	2	2	
32	97075-10030	BOLT PERNO	2	2	
33	92995-10600	WASHER ARANDELA	2	2	
34	6BC-43818-00	PIN, LOWER SHOCK MOUNT PASADOR AMORTIGUADOR INFERIOR	1	1	
35	90386-22M98	BUSH BUJE	2	2	

FIG. 17 POWER TRIM & TILT ASSY 2

COMPONER Y PODER VARILLA 2



60C1200-1211

REF. NO.	PART NO. CODIGO Nº	DESCRIPTION DESCRIPCION	6E58	6F38	REMARKS OBSERVACIONES
1	64E-4388E-10	BOLT ,SCREW (L:34.7MM) PERNO (L:34.7MM)	4	4	
2	64E-43831-00	CONNECTOR, SHAFT CONEXION EJE	1	1	
3	64E-43868-00	O-RING ANILLO EN O 8	1	1	
4	64E-43830-00	GEAR PUMP ASSY ENGRANAJE BOMBA COMPL.	1	1	
5	72X-43858-00	.BALL .ESFERA	2	2	
6	64E-43843-00	.SCREW, VALVE LOCK .TORNILLO	4	4	
7	64E-43841-00	.PISTON, SHUTTLE .PISTON	2	2	
8	64E-43802-00	.VALVE SUB ASSY .VALVULA PRINCIPAL COMPL.	2	2	
9	6E5-43896-00	..O-RING ..ANILLO EN O	1	1	
10	6G5-43863-00	.O-RING .ANILLO EN O 3	1	1	
11	64E-43851-00	.SEAT, RELIEF VALVE .ASIENTO VALVULA DE DESCARGA	1	1	
12	64E-43858-00	.BALL .ESFERA	1	1	
13	64E-43859-00	.PIN, VALVE SUPPORT .PASADOR VALVULA SOPORTE	1	1	
14	64E-43855-00	.SPRING, UP RELIEF .RESORTE SEGURIDAD SUPERIOR	1	1	
15	64E-43850-00	.VALVE SUB ASSY .VALVULA COMPL.	1	1	
16	64E-43865-00	.O-RING .ANILLO EN O 5	1	1	
17	64E-43816-00	.FILTER 1 .FIELTRO 1	2	2	
18	64E-43858-00	.BALL .ESFERA	2	2	
19	64E-43817-10	FILTER 2 FIELTRO 2	1	1	
20	64E-43860-00	MANUAL VALVE SUB-ASSY VALVULA SUB-COMPL.	1	1	
21	72X-85075-L0	.O-RING .ANILLO EN O 5	1	1	
22	64E-43827-00	.RING SET .ESFERA	1	1	
23	64E-4387A-00	..O-RING ..ANILLO O	1	1	
24	64E-43873-00	..RING, BACK UP ..ANILLO	1	1	
25	64E-43875-00	RING, SNAP ANILLO	1	1	
26	64E-43879-10	SCREW, WITH WASHER TORNILLO CON RONDANA	1	1	
27	64E-43879-00	SCREW, WITH WASHER TORNILLO CON RONDANA	2	2	

FIG. 17 POWER TRIM & TILT ASSY 2

COMPONER Y PODER VARILLA 2

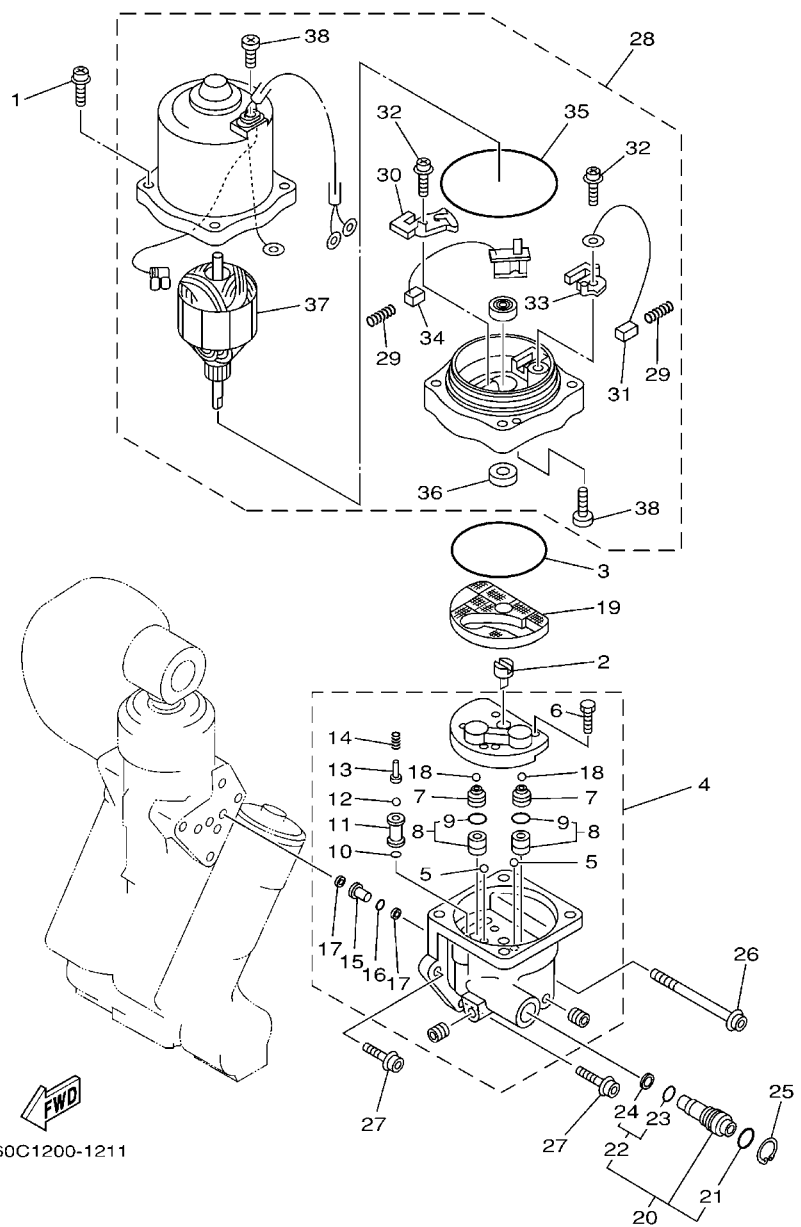

60C1200-1211

REF. NO.	PART NO. CODIGO Nº	DESCRIPTION DESCRIPCION	6E58	6F38	REMARKS OBSERVACIONES
28	64E-43880-02	MOTOR ASSY MOTOR COMPL.	1	1	
29	6H1-4386K-10	.SPRING, BRUSH .RESORTE, ESCOBILLA	2	2	
30	64E-4380J-00	.HOLDER, BRUSH .PORTAESCOBILLA	1	1	
31	64E-43891-00	.BRUSH 1 .ESCOBILLA 1	1	1	
32	97607-04310	.SCREW, WITH WASHER .TORNILLO CAB CON PLANA C/ARAN	2	2	
33	64E-4380F-00	.HOLDER, BRUSH 2 .PORTAESCOBILLA 2	1	1	
34	64E-43892-00	.BRUSH 2 .ESCOBILLA 2	1	1	
35	6G5-43865-00	.O-RING .ANILLO EN O 5	1	1	
36	93102-08M43	.OIL SEAL .SELLO ACEITE	1	1	
37	64E-43805-00	.ARMATURE ASSY .INDUCIDO COMPL.	1	1	
38	64E-43843-10	.SCREW, VALVE LOCK .TORNILLO	3	3	

FIG. 18 UPPER CASING

FUNDA SUPERIOR

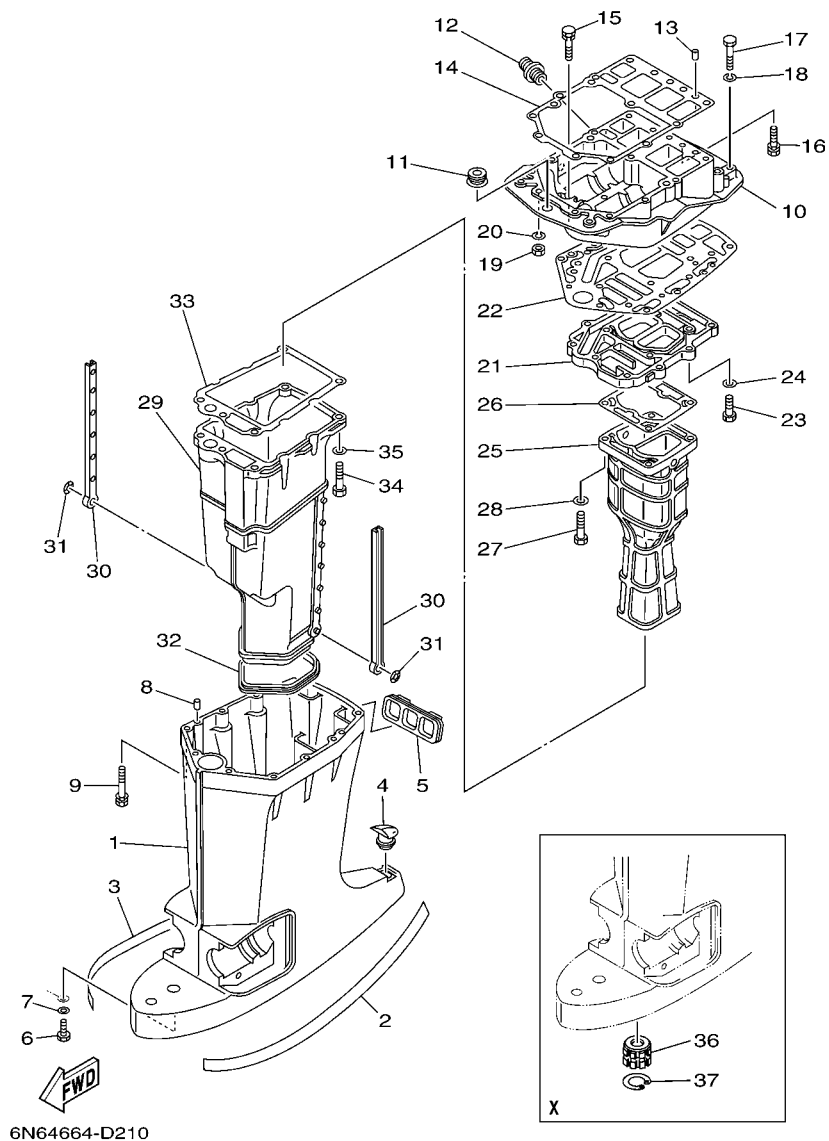

6N64664-D210

REF. NO.	PART NO. CODIGO Nº	DESCRIPTION DESCRIPCION	6E68	6F38	REMARKS OBSERVACIONES
1	6E5-45111-02-8D	CASING, UPPER CAJA SUPERIOR	1	1	L(20.3") L(20.3")
	6E5-45111-23-8D	CASING, UPPER CAJA SUPERIOR	1	1	X(25.3") X(25.3")
2	6R3-42791-41	MARK 1 MARCA 1	1	1	
3	6R3-42792-41	MARK MARCA	1	1	
4	6E5-45155-00	CAP TAPA	1	1	
5	6E5-42769-00	SEAL, RUBBER SELLO DE GOMA	1	1	
6	97095-06010	BOLT PERNO	1	1	
7	92995-06600	WASHER ARANDELA	1	1	
8	93608-12M05	PIN, DOWEL PASADOR DE CLAVIJA	2	2	
9	90119-08078	BOLT, WITH WASHER TORNILLO CON ARANDELA	6	6	
10	6G5-41137-02-94	GUIDE, EXHAUST GUIA DE ESCAPE	1	1	
11	6E5-42724-00	GROMMET TAPON	1	1	
12	6G5-12581-00	JOINT, HOSE 1 CONEXION	1	1	
13	93608-12M05	PIN, DOWEL PASADOR DE CLAVIJA	2	2	
14	6G5-45113-A1	GASKET, UPPER CASING EMPAQUE	1	1	
15	90119-08M79	BOLT, WITH WASHER TORNILLO CON ARANDELA	2	2	
16	90119-08077	BOLT, WITH WASHER TORNILLO CON ARANDELA	4	4	
17	97095-08045	BOLT PERNO	2	2	
18	92995-08100	WASHER ARANDELA	2	2	
19	95380-08700	NUT TUERCA	2	2	
20	92995-08100	WASHER ARANDELA	2	2	
21	6G5-41131-01-5B	MANIFOLD, EXT. 1 TUBO MULTIPLE DE ESCAPE	1	1	
22	6G5-45114-A1	GASKET, UPPER CASING EMPAQUE	1	1	
23	97095-08030	BOLT PERNO	4	4	
24	92995-08600	WASHER ARANDELA	4	4	
25	6E5-41132-10-5B	MANIFOLD, EXHAUST TUBO MULTIPLE DE ESCAPE	1		
	6L1-41132-00-5B	MANIFOLD, EXHAUST TUBO MULTIPLE DE ESCAPE		1	

FIG. 18 UPPER CASING

FUNDA SUPERIOR

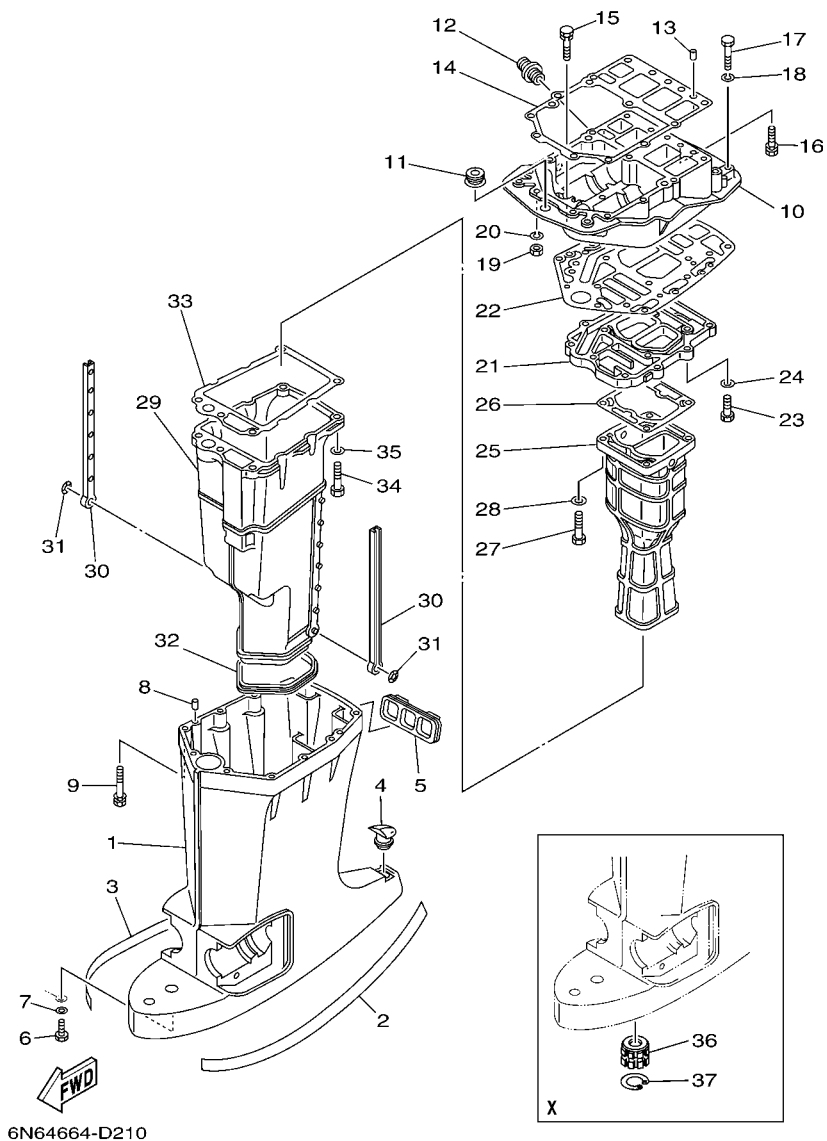

REF. NO.	PART NO. CODIGO Nº	DESCRIPTION DESCRIPCION	6E58	6F38	REMARKS OBSERVACIONES
26	6E5-41134-A0	GASKET, EXHAUST MANIFOLD EMPAQUE	1		
	6G5-41134-A1	GASKET, EXHAUST MANIFOLD EMPAQUE		1	
27	97095-08045	BOLT PERNO	4	4	
28	92995-08600	WASHER ARANDELA	4	4	
29	6E5-14711-01-5B	MUFFLER 1 SILENCIADOR 1	1	1	
30	6E5-14737-00	DAMPER, MUFFLER AMORTIGUADOR DE SILENCIADOR	2	2	
31	90183-05M02	NUT, SPRING TUERCA DE RESORTE	2	2	
32	6E5-45123-00	GASKET, MUFFLER EMPAQUE SILENCIADOR	1	1	
33	6E5-41135-A0	GASKET, EXHAUST MANIFOLD EMPAQUE	1	1	
34	97095-08045	BOLT PERNO	5	5	
35	92995-08600	WASHER ARANDELA	5	5	
36	6E5-45318-00	BUSHING, DRIVE SHAFT BUJE, EJE DE MANDO	1	1	X(25.3") X(25.3")
37	93420-36M01	CIRCLIP SEGURO	1	1	X(25.3") X(25.3")

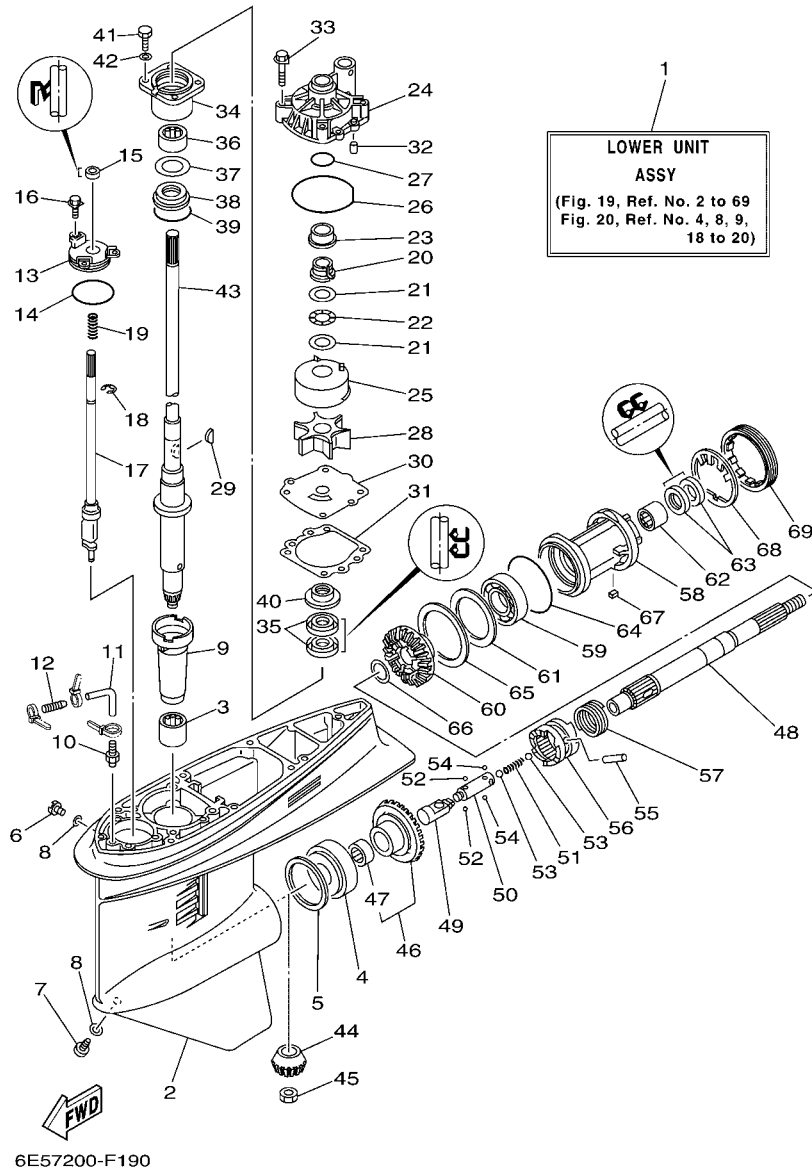

6E57200-F190

FIG. 19 LOWER CASING & DRIVE 1 IMPULSOR E INFERIOR 1

REF. NO.	PART NO. CODIGO Nº	DESCRIPTION DESCRIPCION	6E58	6F38	REMARKS OBSERVACIONES
1	6E5-45300-17-8D	LOWER UNIT ASSY CONJUNTO UNIDAD INFERIOR	1	1	L(20.3"),RH L(20.3"),RH
	6E5-45300-27-8D	LOWER UNIT ASSY CONJUNTO UNIDAD INFERIOR	1	1	X(25.3"),RH X(25.3"),RH
2	6E5-45301-05-8D	CASING, LOWER FUNDA INFERIOR COMPLETA	1	1	
3	93315-628U9	BEARING COJINETE DE RODILLOS	1	1	
4	93332-000U7	BEARING COJINETE	1	1	
5	6E5-45567-01	SHIM (T:0.10MM) LAMINA(T:0.10MM)	1	1	UR UR
	6E5-45567-10	SHIM (T:0.12MM) LAINA (T:0.12MM)	1	1	UR UR
	6E5-45567-20	SHIM (T:0.15MM) LAINA (T:0.15MM)	1	1	UR UR
	6E5-45567-30	SHIM (T:0.18MM) LAINA (T:0.18MM)	1	1	UR UR
	6E5-45567-40	SHIM (T:0.30MM) LAINA (T:0.30MM)	1	1	UR UR
	6E5-45567-50	SHIM (T:0.40MM) LAINA (T:0.40MM)	1	1	UR UR
	6E5-45567-60	SHIM (T:0.50MM) LAINA (T:0.50MM)	1	1	UR UR
6	90340-08002	PLUG, STRAIGHT SCREW TORNILLO, DE DRENAJE	1	1	
7	688-45341-10	PLUG, DRAIN TAPON, DREN	1	1	
8	90430-08020	GASKET JUNTA	2	2	
9	6E5-45536-00	SLEEVE, DRIVE SHAFT CAMISA EJE DE MANDO	1	1	
10	6E5-45378-00	NIPPLE, HOSE NIPLE MANGUERA	1	1	
	90445-07ME8	HOSE (L80) TUBO (L80)	1	1	L(20.3") L(20.3")
	90445-07ME9	HOSE (L120) TUBO (L120)	1	1	X(25.3") X(25.3")
12	6E5-83558-10	END, NIPPLE EXTREMO DE NIPLE	1	1	
13	6E5-45321-00	PLATE PLACA	1	1	
14	93210-58144	O-RING ANILLO O	1	1	
15	93106-09014	OIL SEAL SELLO ACEITE	1	1	
16	90119-06M10	BOLT, WITH WASHER TORNILLO CON ARANDELA	3	3	
17	6E5-44150-02	SHIFT CAM ASSY CONJUNTO EJE LEVA COMPL.	1	1	
18	99001-08600	CIRCLIP PRESILLA REDONDA	1	1	
19	90501-11M10	SPRING, COMPRESSION RESORTE DE COMPRESION	1	1	

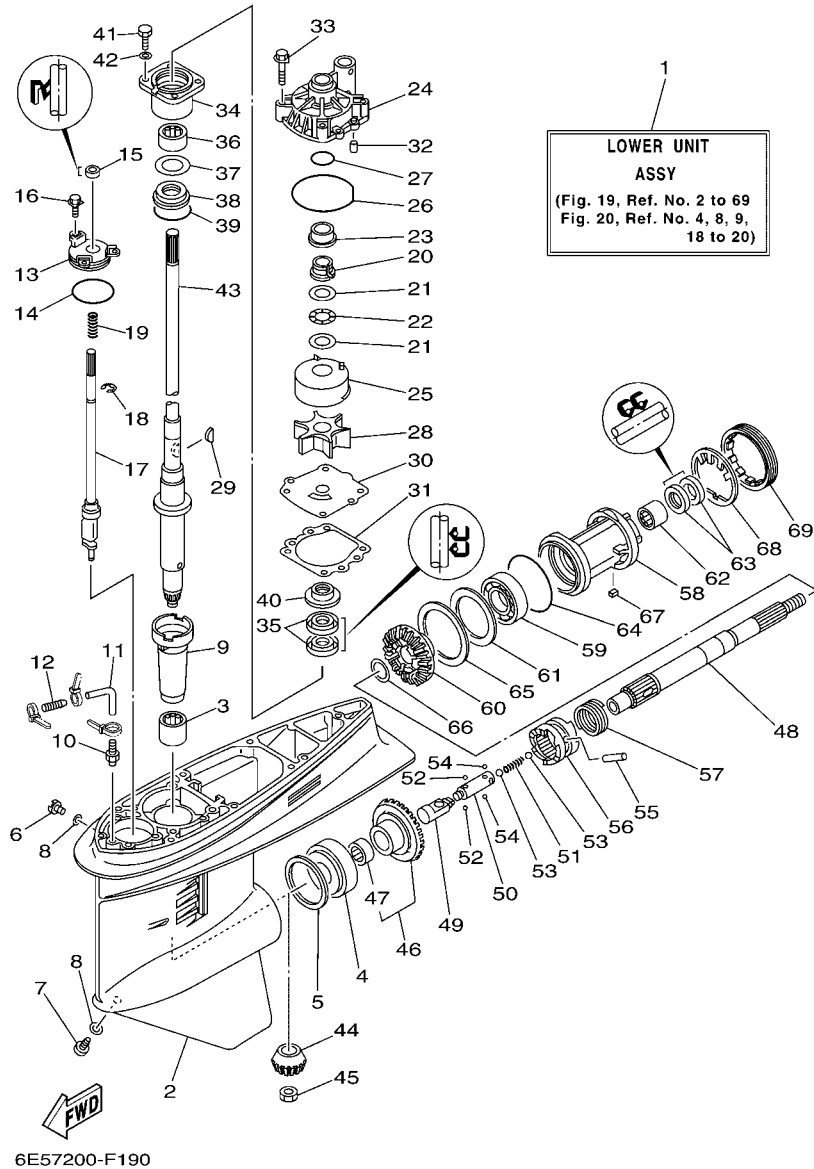
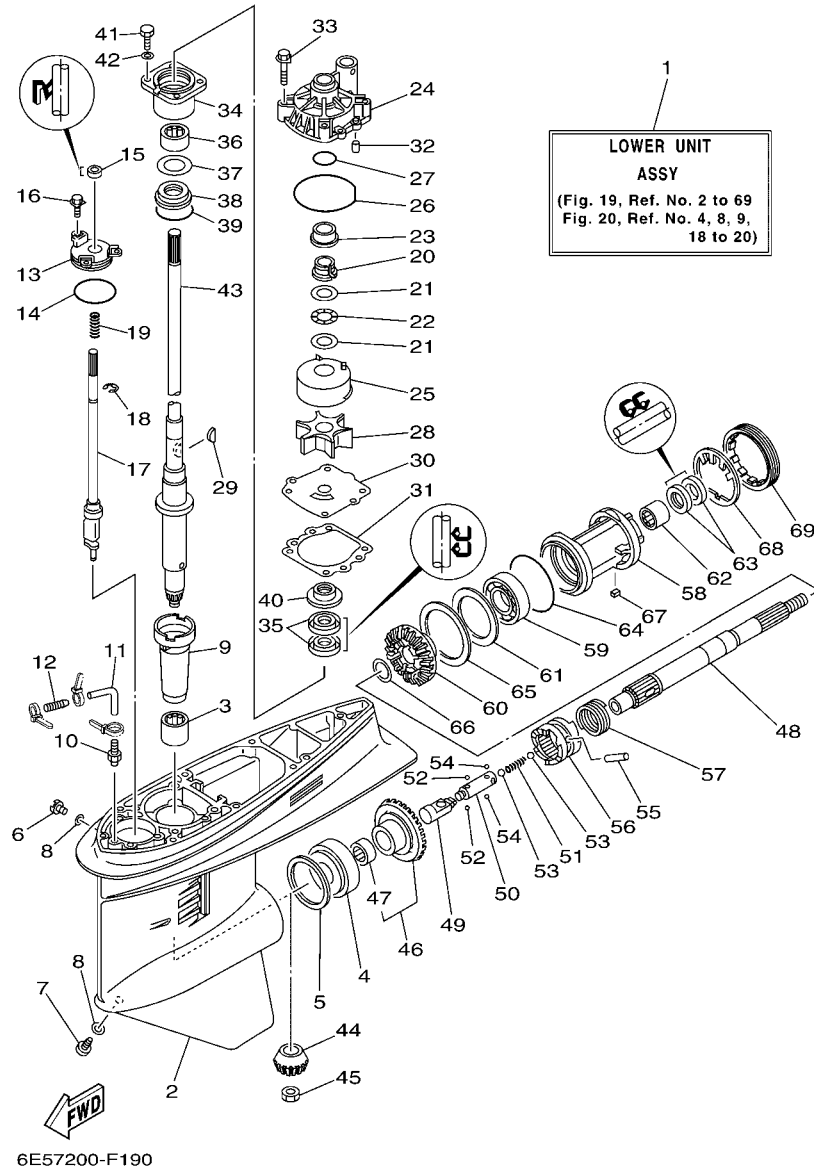

FIG. 19 LOWER CASING & DRIVE 1 IMPULSOR E INFERIOR 1

REF. NO.	PART NO. CODIGO Nº	DESCRIPTION DESCRIPCION	6E58	6F38	REMARKS OBSERVACIONES
20	61A-45538-00	SPACER 1 ESPACIADOR 1	1	1	
21	90201-22M01	WASHER, PLATE ARANDELA PLANA	2	2	
22	90206-22M19	WASHER, WAVE ARANDELA ONDULADA	1	1	
23	61A-45527-00	COLLAR, DRIVE SHAFT COLLAR EJE FLECHA DE PROPULSION	1	1	
24	61A-44311-01	HOUSING, WATER PUMP CAJA BOMBA DE AGUA	1	1	
25	61A-44322-02	INSERT, CARTRIDGE CARTUCHO	1	1	FOR STD FOR STD
	6R3-44322-42	INSERT, CARTRIDGE CARTUCHO	1	1	FOR CHROMATE FOR CHROMATE
26	93210-86M38	O-RING ANILLO O	1	1	
27	93210-37160	O-RING ANILLO O	1	1	
28	6E5-44352-01	IMPELLER IMPULSOR	1	1	
29	90280-04M05	KEY, WOODRUFF CUNA WOODRUFF	1	1	
30	6E5-44323-00	OUTER PLATE, CARTRIDGE PLACA EXTERIOR DEL CARTUCHO	1	1	FOR STD FOR STD
	6E5-44323-40	OUTER PLATE, CARTRIDGE PLACA EXTERIOR DEL CARTUCHO	1	1	FOR CHROMATE FOR CHROMATE
31	6E5-44315-A0	GASKET, WATER PUMP EMPAQUE	1	1	
32	93606-12019	PIN, DOWEL PASADOR DE CLAVIJA	2	2	
33	90119-08M14	BOLT, WITH WASHER TORNILLO CON ARANDELA	4	4	
34	6E5-45331-00-94	HOUSING, BEARING CAJA DE COJINETE	1	1	
35	93101-28M16	OIL SEAL SELLO ACEITE	2	2	
36	93317-330U2	BEARING COJINETE	1	1	
37	6E5-45587-01	SHIM (T:0.10MM) LAINA (T:0.10MM)	1	1	UR UR
	6E5-45587-10	SHIM (T:0.12MM) LAINA (T:0.12MM)	1	1	UR UR
	6E5-45587-20	SHIM (T:0.15MM) LAINA (T:0.15MM)	1	1	UR UR
	6E5-45587-30	SHIM (T:0.18MM) LAINA (T:0.18MM)	1	1	UR UR
	6E5-45587-40	SHIM (T:0.30MM) LAINA (T:0.30MM)	1	1	UR UR
	6E5-45587-50	SHIM (T:0.40MM) LAINA (T:0.40MM)	1	1	UR UR
	6E5-45587-60	SHIM (T:0.50MM) LAINA (T:0.50MM)	1	1	UR UR
38	93341-930V2	BEARING COJINETES CON RODAMIENTOS	1	1	



6E57200-F190

FIG. 19 LOWER CASING & DRIVE 1 IMPULSOR E INFERIOR 1

REF. NO.	PART NO. CODIGO Nº	DESCRIPTION DESCRIPCION	6E58	6F38	REMARKS OBSERVACIONES
39	93210-55M14	O-RING ANILLO O	1	1	
40	6E5-45344-00	COVER, OIL SEAL CUBIERTA SELLO ACEITE	1	1	
41	97095-08025	BOLT PERNO	4	4	
42	92995-08600	WASHER ARANDELA	4	4	
43	6E5-45501-01	DRIVE SHAFT COMP. EJE DE MANDO COMPL.	1	1	L(20.3")
	6E5-45501-21	DRIVE SHAFT COMP. EJE DE MANDO COMPL.	1	1	L(20.3") X(25.3") X(25.3")
44	6E5-45551-02	PINION (13T) PINON (13T)	1	1	
45	90170-16M01	NUT TUERCA	1	1	
46	6E5-45560-01	GEAR 1 (26T) ENGRANAJE 1 (26T)	1	1	
47	93315-425U7	BEARING COJINETE DE RODILLOS	1	1	
48	6E5-45611-01	SHAFT, PROPELLER EJE PROPUSOR	1	1	
49	6E5-45641-03	SHIFTER CAMBIO	1	1	
50	6E5-45634-01	SLIDE, SHIFT DESLIZADOR, CAMBIO	1	1	
51	90501-16M37	SPRING, COMPRESSION RESORTE DE COMPRESION	1	1	
52	93507-32009	BALL ESFERA	2	2	
53	93511-32017	BALL ESFERA	2	2	
54	93503-16003	BALL ESFERA	2	2	
55	90250-08M07	PIN, STRAIGHT PASADOR CILINDRICO	1	1	
56	6E5-45631-01	CLUTCH, DOG EMBRAGUE DE GARRA	1	1	
57	6E5-45633-01	RING, CROSS PIN ANILLO DE PASADOR	1	1	
58	6E5-45332-00-94	HOUSING, BEARING CAJA BALERO 2	1	1	
59	93306-208U0	BEARING COJINETE	1	1	
60	6E5-45571-01	GEAR 2 (26T) ENGRANAJE 2 (26T)	1	1	
61	6E5-45576-00	WASHER, THRUST ARANDELA DE EMPUJE AXIAL	1	1	
62	93315-43061	BEARING COJINETE DE RODILLOS	1	1	
63	93101-30M17	OIL SEAL SELLO ACEITE	2	2	
64	93210-86M39	O-RING ANILLO O	1	1	

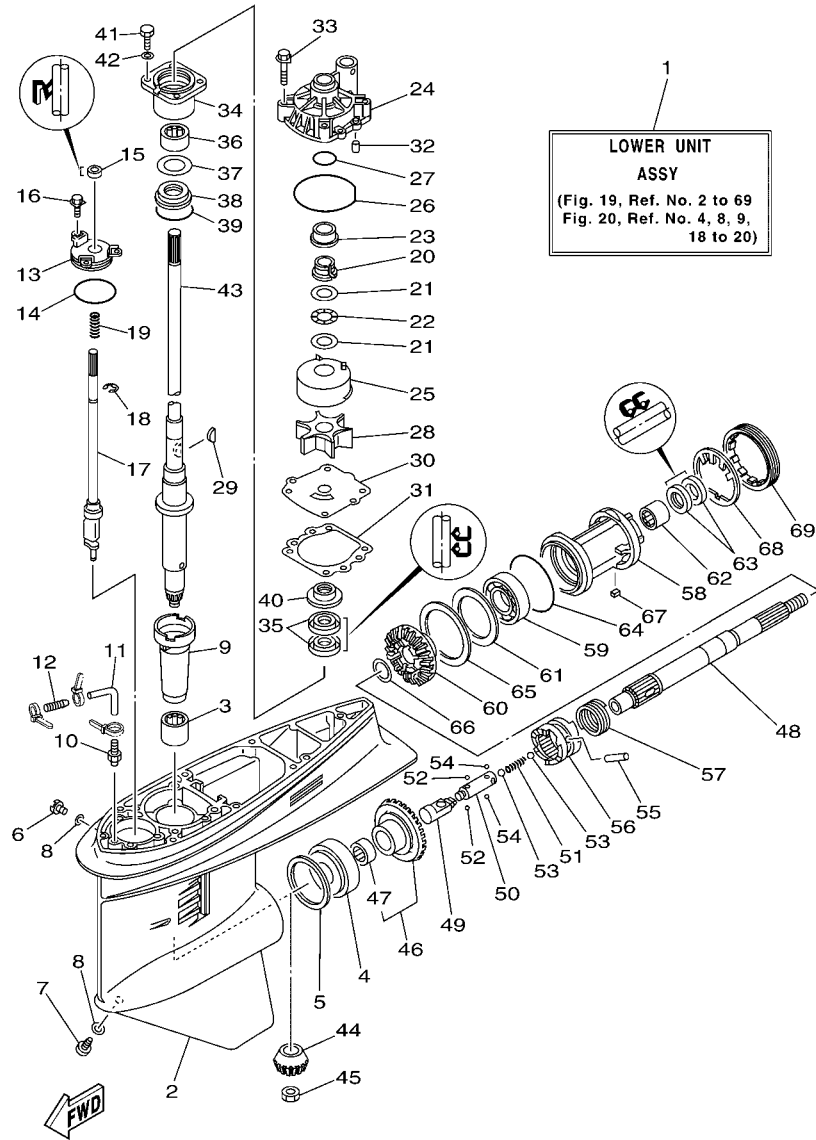

6E57200-F190

FIG. 19 LOWER CASING & DRIVE 1 IMPULSOR E INFERIOR 1

REF. NO.	PART NO. CODIGO Nº	DESCRIPTION DESCRIPCION	6E58	6F38	REMARKS OBSERVACIONES
65	6L6-45577-00	SHIM (T:0.10MM) LAINA (T:0.10MM)	1	1	UR
	6L6-45577-10	SHIM (T:0.12MM) LAINA (:0.12MM)	1	1	UR
	6L6-45577-20	SHIM (T:0.15MM) LAINA (T:0.15MM)	1	1	UR
	6L6-45577-30	SHIM (T:0.18MM) LAINA (T:0.18MM)	1	1	UR
	6L6-45577-40	SHIM (T:0.30MM) LAINA (T:0.30MM)	1	1	UR
	6L6-45577-50	SHIM (T:0.40MM) LAINA (T:0.40MM)	1	1	UR
	6L6-45577-60	SHIM (T:0.50MM) LAINA (T:0.50MM)	1	1	UR
66	90201-30M92	WASHER, PLATE ARANDELA PLANA	1	1	
67	90282-04010	KEY, STRAIGHT CHAVETA, RECTA	1	1	
68	688-45383-02	WASHER, CLAW ARANDELA DE UNA	1	1	
69	688-45384-00	NUT TUERCA	1	1	

FIG. 20 LOWER CASING & DRIVE 2

IMPULSOR E INFERIOR 2

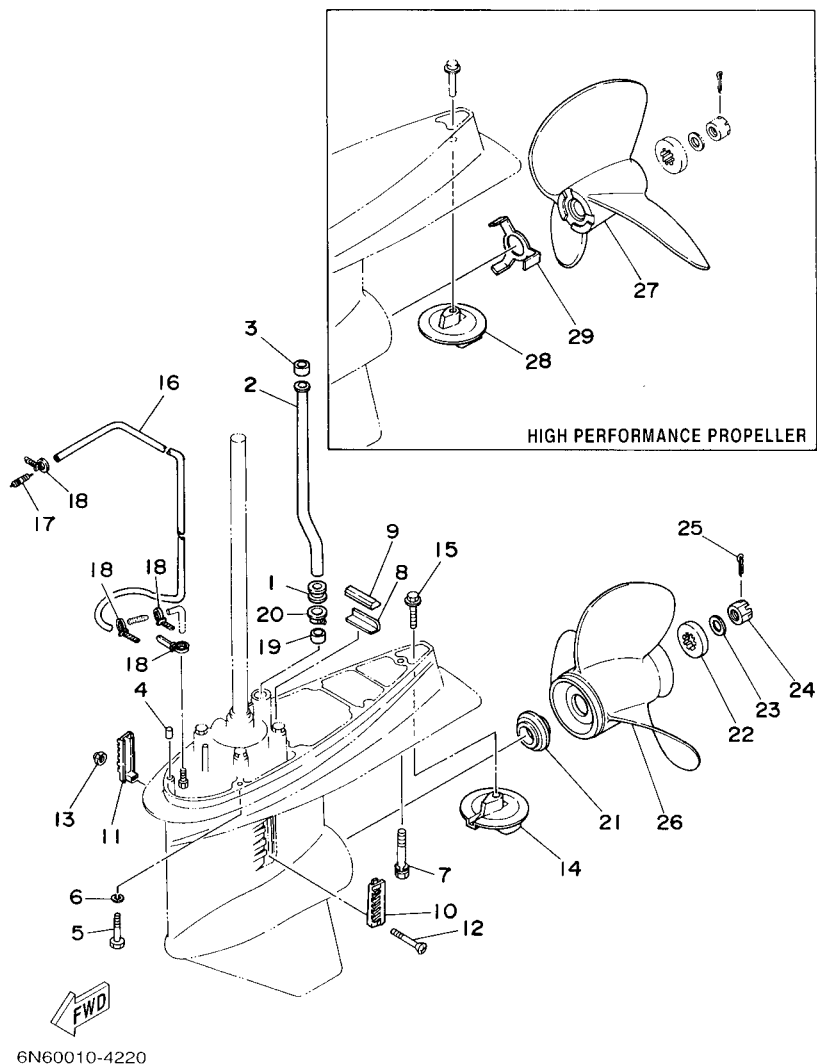

REF. NO.	PART NO. CODIGO Nº	DESCRIPTION DESCRIPCION	6E58	6F38	REMARKS OBSERVACIONES
1	6E5-44366-00	DAMPER, WATER SEAL GOMA DEL SELLO DE AGUA	1	1	
2	6E5-44361-00	TUBE, WATER TUBO DE AGUA	1	1	L(20.3") L(20.3")
	6E5-44361-20	TUBE, WATER TUBO DE AGUA	1	1	X(25.3") X(25.3")
3	6E5-44365-00	DAMPER, WATER SEAL HULE DE SELLO DE AGUA	1	1	
4	93608-12M05	PIN, DOWEL PASADOR DE CLAVIJA	2	2	
5	97075-10045	BOLT PERNO	6	6	
6	92995-10100	WASHER ARANDELA	6	6	
7	90119-10M89	BOLT, WITH WASHER TORNILLO CON ARANDELA	1	1	
8	663-45376-00-94	GUIDE, SEAL DAMPER GUIA DE SELLO GOMA	1	1	
9	688-45375-00	DAMPER, SEAL GOMA DE SELLO	1	1	
10	688-45214-02	COVER, WATER INLET 1 CUBIERTA ENTRADA AGUA 1	1	1	
11	688-45215-02	COVER, WATER INLET 2 CUBIERTA ENTRADA AGUA 2	1	1	
12	90152-05M07	SCREW, COUNTERSUNK TORNILLO EMBUTIDO	1	1	
13	90185-05002	NUT, SELF-LOCKING TUERCA AUTOBLOCANTE	1	1	
14	6E5-45371-01	TAB-TRIM QUILLA ESTABILIZADOR	1	1	
15	90105-10M00	BOLT, FLANGE TORNILLO	1	1	
16	90445-07MF0	HOSE (L1030) TUBO (L1030)	1	1	
17	6E5-83558-00	END, NIPPLE EXTREMO DE NIPLE	1	1	
18	90465-11M10	CLAMP BRIDA	4	4	
19	6E5-44365-00	DAMPER, WATER SEAL HULE DE SELLO DE AGUA	1	1	
20	6E5-44312-00	COVER, WATER PUMP HOUSING CUBIERTA CAJA BOMBA DE AGUA	1	1	
21	6E5-45987-01	SPACER ESPACIADOR	1	1	
22	688-45997-01	SPACER ESPACIADOR	1	1	
23	92990-18200	WASHER ARANDELA PLANA	1	1	
24	90171-18M04	NUT, CASTLE TUERCA ENTALLADA	1	1	
25	91490-40030	PIN, COTTER CHAVETA	1	1	
26	6E5-45941-00-EL	PROPELLER (3X13"X19"-K) PROPELA (3X13"X19"-K)	1	1	UR UR

FIG. 20 LOWER CASING & DRIVE 2 IMPULSOR E INFERIOR 2

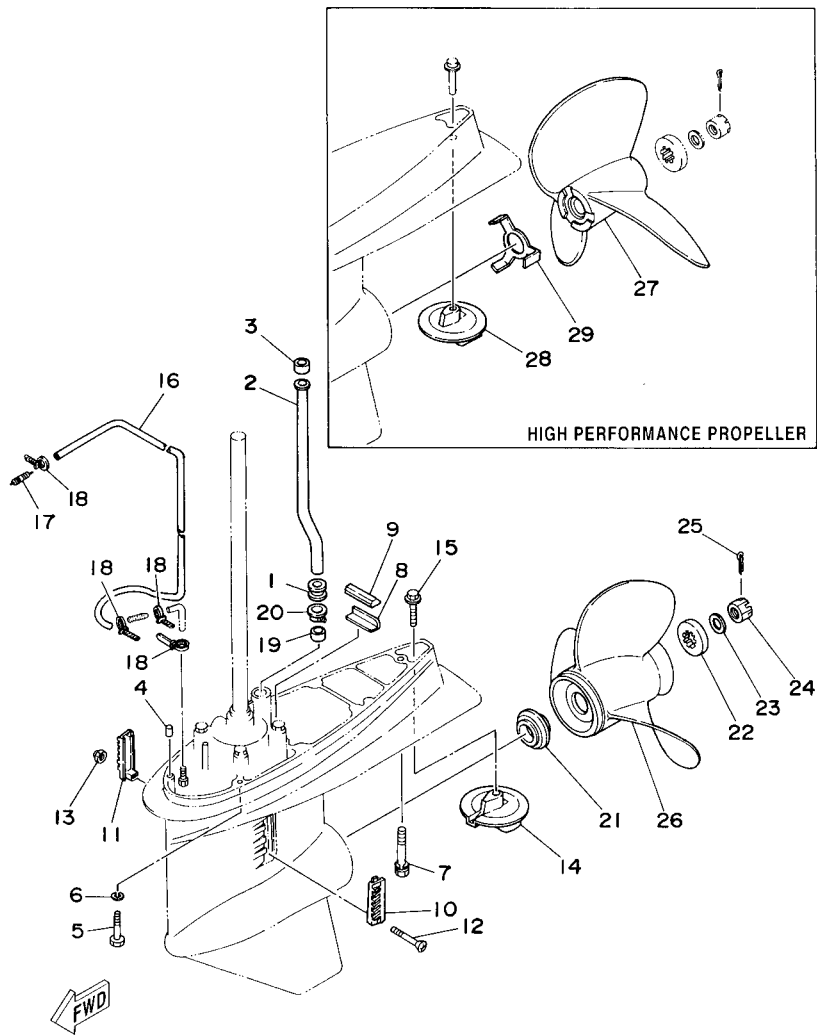

6N60010-4220

REF. NO.	PART NO. CODIGO Nº	DESCRIPTION DESCRIPCION	6E68	6F38	REMARKS OBSERVACIONES
26	6E5-45943-00-EL	PROPELLER (3X12-5/8"X21"-K) PROPELA (3X12-5/8"X21"-K)	1	1	UR UR
	6E5-45945-01-EL	PROPELLER (3X13-1/4"X17"-K) PROPELA (3X13-1/4"X17"-K)	1	1	UR UR
	6E5-45947-00-EL	PROPELLER (3X13-1/2"X15"-K) PROPELA (3X13-1/2"X15"-K)	1	1	UR UR
	6E5-45949-00-EL	PROPELLER (3X13-5/8"X13"-K) PROPELA (3X13-5/8"X13"-K)	1	1	UR UR
	6E5-45952-00-EL	PROPELLER (3X13"X23"-K) PROPELA (3X13"X23"-K)	1	1	UR UR
	6E5-45954-00-EL	PROPELLER (3X14"X11"-K) PROPELA (3X14"X11"-K)	1	1	UR UR
	6E5-45956-00-EL	PROPELLER (3X13"X25"-K) PROPELA (3X13"X25"-K)	1	1	UR UR
	688-45930-02-98	PROPELLER (3X13"X17"-K) PROPELA (3X13"X17"-K)	1	1	UR UR
	688-45932-60-98	PROPELLER (3X13-1/2"X14"-K) PROPELA (3X13-1/2"X14"-K)	1	1	UR UR
	688-45970-03-98	PROPELLER (3X13"X19"-K) PROPELA (3X13"X19"-K)	1	1	UR UR
	688-45972-02-98	PROPELLER (3X13"X21"-K) PROPELA (3X13"X21"-K)	1	1	UR UR
	688-45974-02-98	PROPELLER (3X13"X23"-K) PROPELA (3X13"X23"-K)	1	1	UR UR
	688-45976-01-98	PROPELLER (3X13"X25"-K) PROPELA (3X13"X25"-K)	1	1	UR UR
	688-45978-60-98	PROPELLER (3X13-1/2"X16"-K) PROPELA (3X13-1/2"X16"-K)	1	1	UR UR
27	6E5-45970-10	PROPELLER (3X14"X20"-P) PROPELA (3X14"X20"-P)	1	1	UR UR
	6E5-45972-10	PROPELLER (3X14"X24"-P) PROPELA (3X14"X24"-P)	1	1	UR UR
	6E5-45974-10	PROPELLER (3X14"X28"-P) PROPELA (3X14"X28"-P)	1	1	UR UR
	6E5-45976-10	PROPELLER (3X14"X22"-P) PROPELA (3X14"X22"-P)	1	1	UR UR
	6E5-45978-10	PROPELLER (3X14"X26"-P) PROPELA (3X14"X26"-P)	1	1	UR UR
28	6E5-45371-10	TAB-TRIM QUILLA ESTABILIZADOR	1	1	
29	6E5-45994-10	PLATE, TOOTH PLACA	1	1	

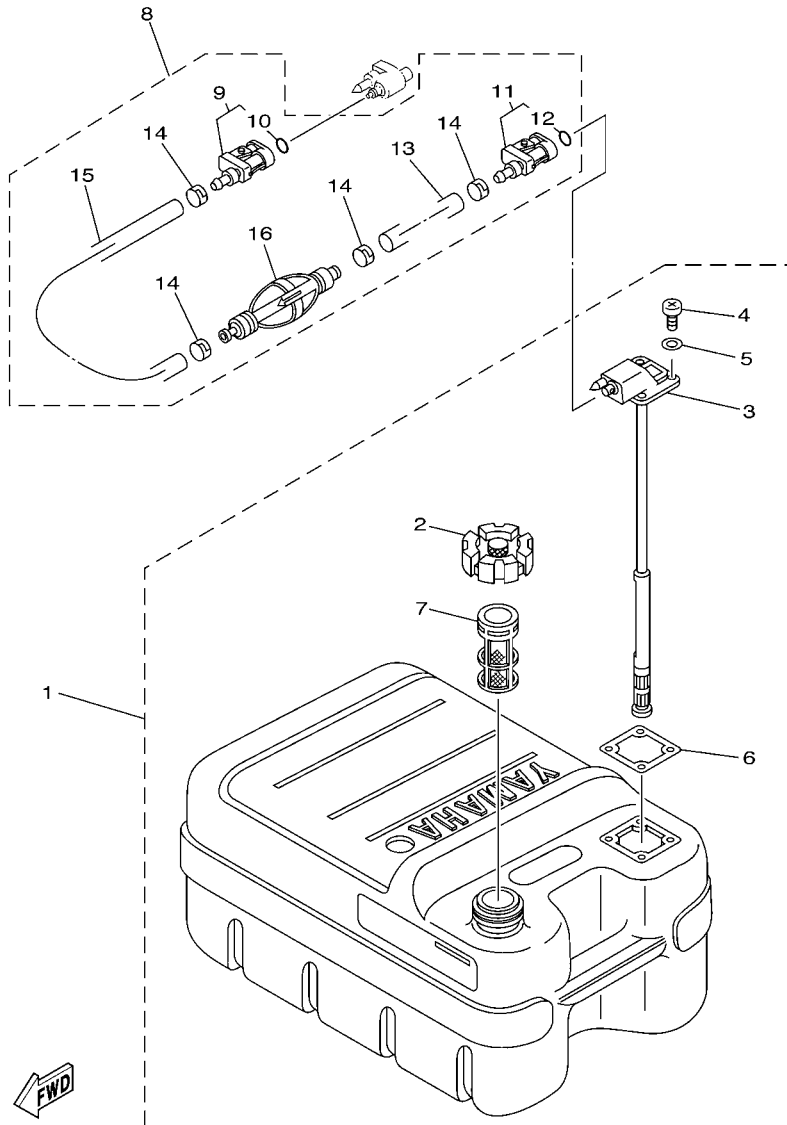
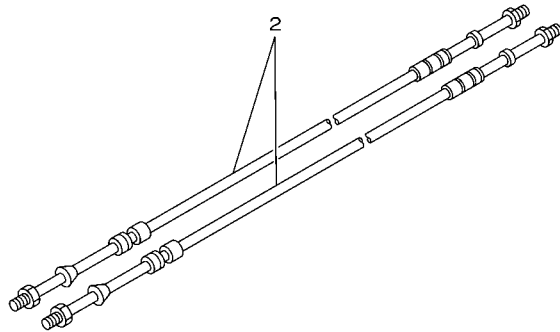
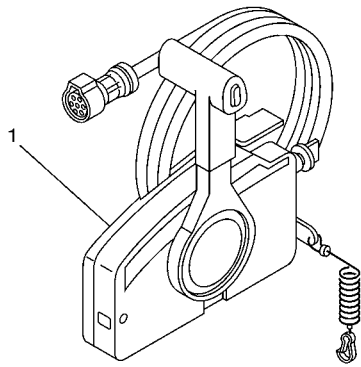

FIG. 21 FUEL TANK

DEPOSITO DE COMBUSTIBLE

REF. NO.	PART NO. CODIGO Nº	DESCRIPTION DESCRIPCION	6E58	6F38	REMARKS OBSERVACIONES
1	6YJ-24201-00	FUEL TANK ASSY (24L) TANQUE DEL COMBUSTIBLE (24L)	1	1	AP AP
	6YJ-24201-10	FUEL TANK ASSY (24L) TANQUE DEL COMBUSTIBLE (24L)	1	1	AP FOR CHN AP FOR CHN
2	6YJ-24610-01	.CAP ASSY .TAPA COMPLETA	1	1	
3	6YJ-24260-00	.FUEL METER ASSY .MEDIDOR DE COMBUSTIBLE COMPL.	1	1	
	6Y1-24260-12	.FUEL METER ASSY .MEDIDOR DE COMBUSTIBLE COMPL.	1	1	FOR CHN FOR CHN
4	90157-05M19	.SCREW, PAN HEAD .TORNILLO CABEZA CONICA PLANA	4	4	
5	6Y1-24329-00	.SEAL .SELLO	4	4	
6	6Y1-24268-00	.GASKET, FUEL METER .EMPAQ MEDIDOR DE COMBUSTIBLE	1	1	
7	6YJ-24167-00	.STRAINER .COLADOR	1	1	
8	6Y2-24306-0B	FUEL PIPE COMP. 1 TUBO COMBUST. COMPL 1	1	1	AP AP
9	6E5-24305-06	.FUEL PIPE JOINT COMP. 2 .CONECTOR MANGUERA COMBUST. 2	1	1	
10	93210-08287	.O-RING .ANILLO O	1	1	
11	6Y2-24305-06	.FUEL PIPE JOINT COMP. 2 .CONECTOR MANGUERA COMBUST. 2	1	1	
12	93210-08287	.O-RING .ANILLO O	1	1	
13	90445-13M01	.HOSE (L2050) .MANGUERA (L2050)	1	1	
14	6E5-24351-01	.BAND 1 .ABRAZADERA 1	4	4	
15	90445-13M00	.HOSE (L850) .MANGUERA (L850)	1	1	
16	61J-24360-11	.PRIMER PUMP ASSY .SOPORTE BOMBA	1	1	



67M0100-8280

FIG. 22 REMOTE CONTROL BOX

CONTROL REMOTO COMPLETO

REF. NO.	PART NO. CODIGO Nº	DESCRIPTION DESCRIPCION	6E58	6F38		REMARKS OBSERVACIONES
1	703-48205-17	REMOTE CONTROL ASSY (10P) REMOTO CONTROL COMPL. (10P)	1	1		AP WITH PT/T SW. AP WITH PT/T SW.
2	701-48320-50	CABLE, REMOTE CONTROL L=15F CABLE CONTROL REMOTO L=15F	2	2		UR UR
	701-48320-80	CABLE, REMOTE CONTROL L=17F CABLE CONTROL REMOTO L=17F	2	2		UR UR
	701-48320-40	CABLE, REMOTE CONTROL L=19F CABLE CONTROL REMOTO L=19F	2	2		UR UR

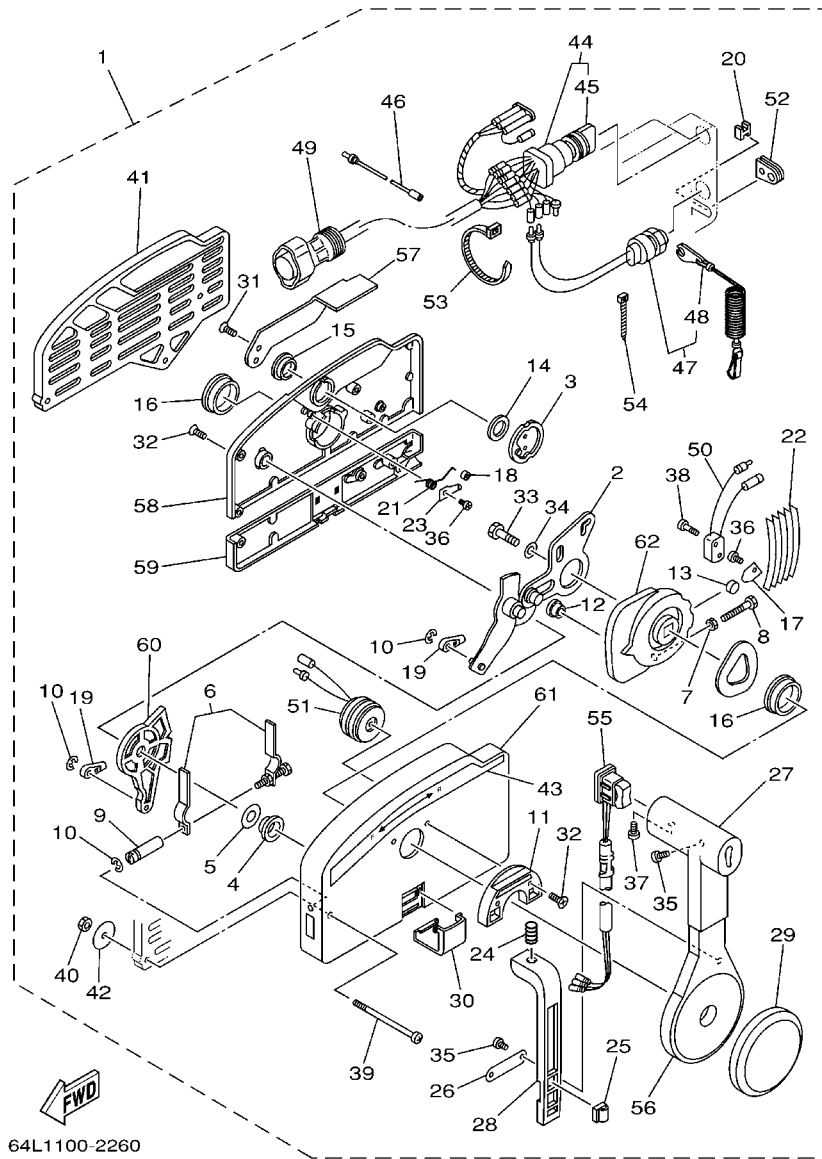
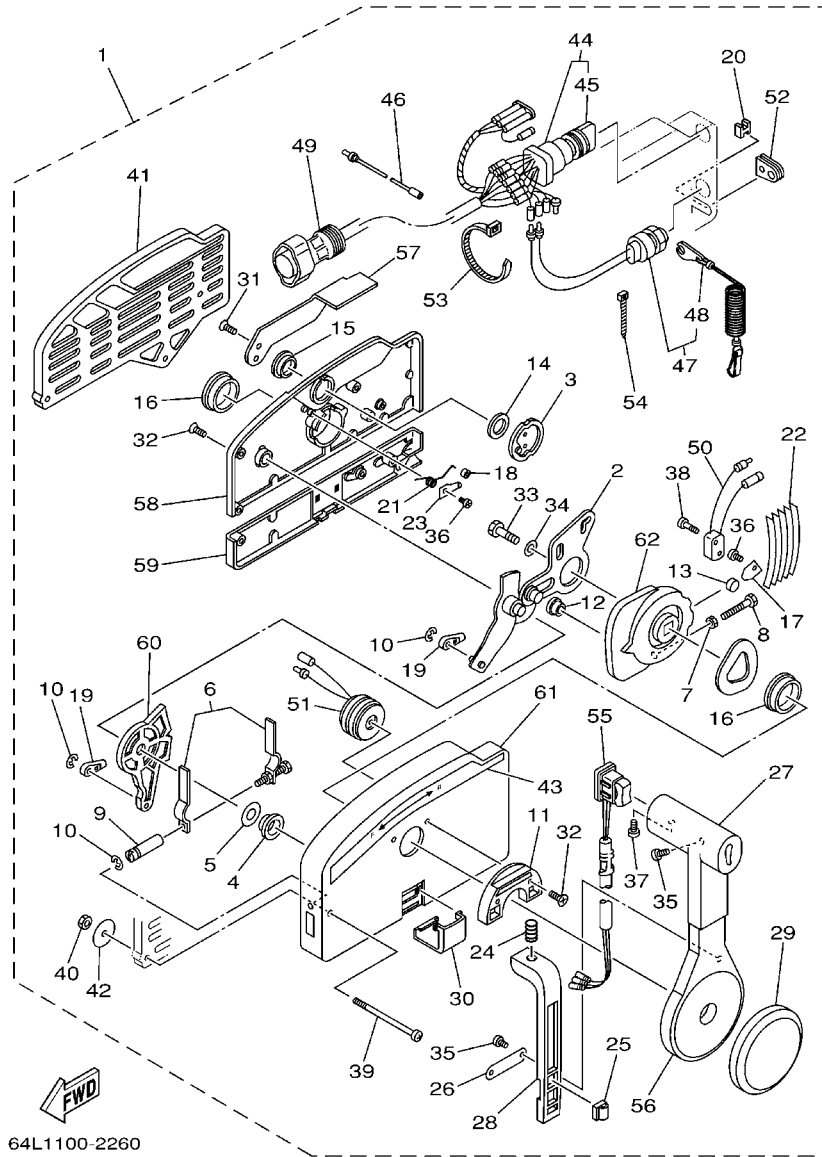

FIG. 23 REMOTE CONTROL ASSY CONTROL REMOTO COMPL

REF. NO.	PART NO. CODIGO Nº	DESCRIPTION DESCRIPCION	6E68	6F38	REMARKS OBSERVACIONES
1	703-48205-17	REMOTE CONTROL ASSY (10P) REMOTO CONTROL COMPL. (10P)	1	1	AP WITH PT/T SW. AP WITH PT/T SW.
2	703-48261-01	.ARM, THROTTLE .BRAZO ACELERADOR	1	1	
3	703-48153-00	.SHAFT, FREE ACCEL. .EJE	1	1	
4	703-48235-00	.BUSHING .BUJE	1	1	
5	703-48268-00	.SPACER .ESPACIADOR 3	1	1	
6	703-48264-00	.FRICTION, THROTTLE .FRICCION DE ACELERADOR	1	1	
7	95380-05600	.NUT .TUERCA	1	1	
8	97380-05025	.BOLT .TORNILLO HEXAGONAL	1	1	
9	703-48265-00	.SHAFT, FRICTION .EJE FRICCION	1	1	
10	93430-06024	.CIRCLIP .SEGURO	3	3	
11	703-48245-00	.PLATE, LOCK .PLACA CERRADURA	1	1	
12	703-48252-00	.ROLLER, CAM .RODILLO LEVA	1	1	
13	701-48248-00	.ROLLER, FREE ACCEL. .RODILLO ACELERADOR LIBRE	1	1	
14	703-48198-00	.WASHER, WAVE .RONDANA ONDULADA 3	1	1	
15	703-48243-00	.BUSHING .BUJE 3	1	1	
16	703-48236-00	.BUSHING 1 .BUJE	2	2	
17	703-48189-00	.RETAINER .RETENEDOR	1	1	
18	703-48234-00	.ROLLER, DETENT .RODILLO	1	1	
19	703-48345-01	.CABLE END, REMOTE CONTROL 2 .TERMINAL CABLE DE CONTROL REMO	2	2	
20	703-48358-00	.ANCHOR, CABLE .ABRAZADERA CABLE	1	1	
21	703-48244-00	.SPRING, FREE ACCEL. .RESORTE ACELERADOR LIBRE	1	1	
22	703-48238-00	.SPRING, DETENT .RESORTE	5	5	
23	703-48246-00	.SPACER .ESPACIADOR	1	1	
24	703-48227-00	.SPRING, NEUTRAL LOCK .RESORTE DE SEGURO	1	1	
25	703-82594-00	.CLAMP .GRAMPA	1	1	WITH PT/T SW. WITH PT/T SW.
26	703-48226-00	.PLATE, STOPPER .PLACA RETEN	1	1	
27	703-48222-00	.GRIP, CONTROL LEVER .MANGO DE PALANCA CONTROL	1	1	SINGLE SINGLE



64L1100-2260

FIG. 23 REMOTE CONTROL ASSY CONTROL REMOTO COMPL

REF. NO.	PART NO. CODIGO Nº	DESCRIPTION DESCRIPCION	6E58	6F38	REMARKS OBSERVACIONES
28	703-48223-00	.LOCK, NEUTRAL .CERRADURA NEUTRO	1	1	
29	703-48225-00	.COVER .CUBIERTA	1	1	
30	703-48219-00	.COVER, LEAD .CUBIERTA	1	1	
31	703-48281-00	.SCREW .TORNILLO 1	2	2	
32	703-48282-00	.SCREW .TORNILLO 2	7	7	
33	97380-08030	.BOLT .TORNILLO HEXAGONAL	1	1	
34	92990-08600	.WASHER, PLATE .ARANDELA PLANA	1	1	
35	98580-04010	.SCREW, PAN HEAD .TORNILLO DE CABEZA CRUZADA	3	3	
36	98580-04006	.SCREW, PAN HEAD .TORNILLO DE CABEZA CRUZADA	2	2	
37	98580-05010	.SCREW, PAN HEAD .TORNILLO DE CABEZA CRUZADA	1	1	
38	98580-03015	.SCREW, PAN HEAD .TORNILLO DE CABEZA CRUZADA	2	2	
39	703-48291-10	.SCREW (M6) .TORNILLO (M6)	3	3	
40	95380-06600	.NUT, HEXAGON .TUERCA	3	3	
41	703-48293-10	.SPACER, REMOTE CONTROL .ESPACIADOR	1	1	SINGLE SINGLE
42	701-48287-00	.WASHER .ARANDELA	3	3	
43	703-48215-00	.GRAPHIC .CALCOMANIA 1	1	1	
44	703-82510-43	.MAIN SWITCH ASSY .CONJUNTO DE LLAVE IGNICION	1	1	
45	703-82577-00	.CAP, KEY .TAPA	1	1	
46	703-82531-00	.WIRE, LEAD (L70) .CABLE CONDUCTOR (L70)	1	1	
47	688-82575-01	.ENGINE STOP SWITCH ASSY .INTERRUPTOR DE PARADA COMPL	1	1	
48	682-82556-00	.LANYARD, STOP SWITCH .RETENER	1	1	
49	688-8258A-20	.EXTENSION, WIRE HARNESS (4.9M) .EXTENSION, ARNES DE CABLES (4.	1	1	(10P) (10P)
50	703-82540-00	.NEUTRAL SWITCH ASSY .INTERRUPTOR NEUTRAL COMPL	1	1	
51	703-83383-02	.BUZZER .ZUMBADOR	1	1	
52	703-48284-00	.GROMMET .TAPON	1	1	
53	703-82591-00	.BAND .BANDA	1	1	
54	703-82592-00	.BAND .BANDA	1	1	

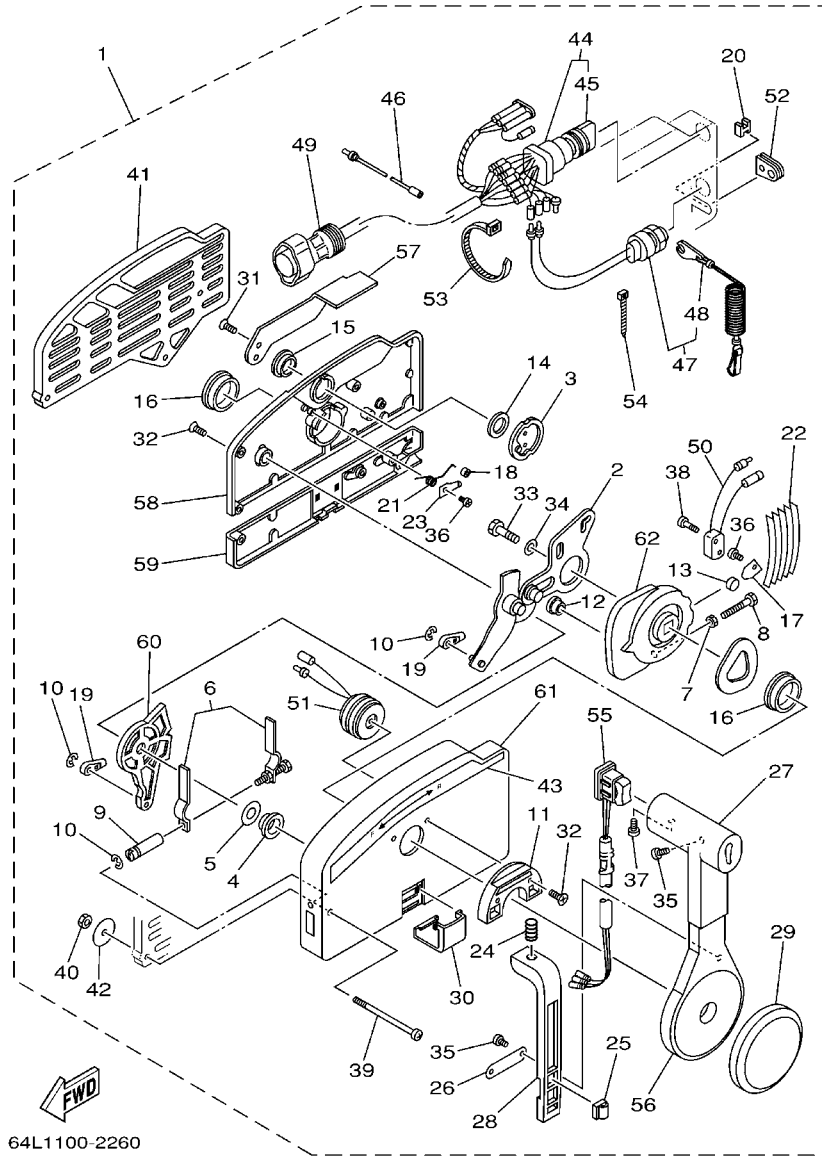
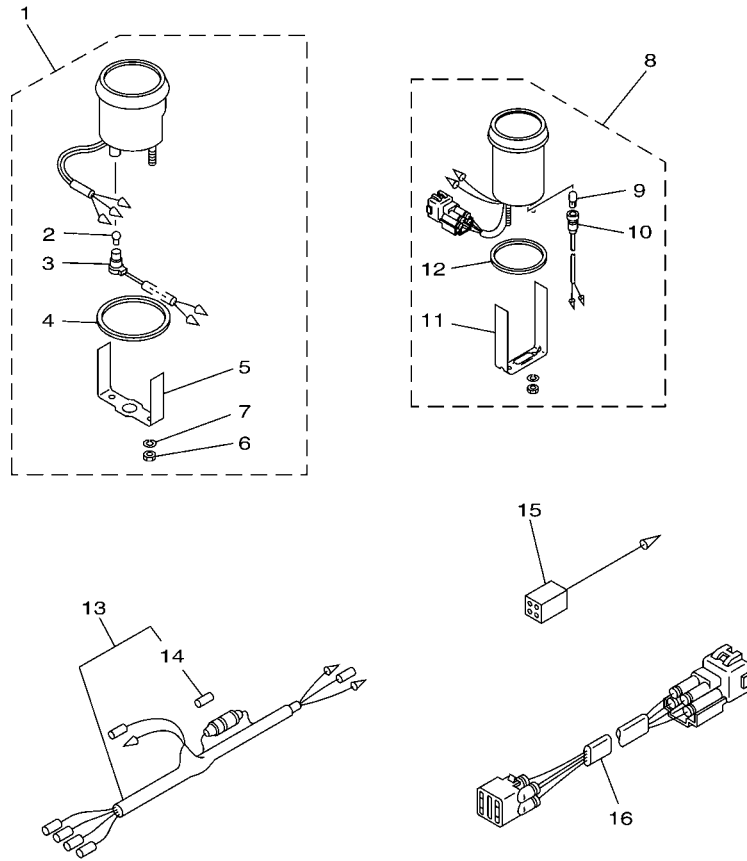

FIG. 23 REMOTE CONTROL ASSY CONTROL REMOTO COMPL

REF. NO.	PART NO. CODIGO Nº	DESCRIPTION DESCRIPCION	6E58	6F38		REMARKS OBSERVACIONES
55	703-82563-02	.TRIM & TILT SWITCH ASSY .INTERRUPTOR DE INCLINACION	1	1		WITH PT/T SW. WITH PT/T SW.
56	703-48221-00	.LEVER, CONTROL .PALANCA CONTROL	1	1		
57	703-48152-00	.KNOB, FREE ACCEL. .PERILLA	1	1		
58	703-48212-00	.BACK PLATE 1 .PLACA TRASERA 1	1	1		
59	703-48213-00	.BACK PLATE 2 .PLACA TRASERA 2	1	1		
60	703-48271-00	.ARM, SHIFT .BRAZO CAMBIADOR	1	1		
61	703-48211-01	.HOUSING,1 .CAJA	1	1		
62	703-48232-00	.GEAR .ENGRANAJE 1	1	1		



6H37200-G260

FIG. 24 METER

MEDIDOR

REF. NO.	PART NO. CODIGO Nº	DESCRIPTION DESCRIPCION	6E58	6F38	REMARKS OBSERVACIONES
1	6Y7-83540-20	TACHOMETER ASSY TACOMETRO COMPLETO	1	1	AP WITHOUT OIL LAMP AP WITHOUT OIL LAMP
2	6Y5-83517-00	.BULB (T10, 12V-1.7W) .BOMBILLA (T10, 12V-1.7W)	1	1	
3	6Y5-83536-40	.SOCKET, METER .ENCASTRE DE MEDIDOR	1	1	
4	6Y5-83523-00	.DAMPER .AMORTIGUADOR	1	1	
5	6Y5-83514-00	.PLATE, FITTING .PLACA ACCESORIA	1	1	
6	95380-05600	.NUT .TUERCA	2	2	
7	92990-05100	.WASHER, SPRING .ARANDELA PLANA	2	2	
8	6Y7-83670-00	TRIM METER ASSY. MEDIDOR DE INCLINACION	1	1	AP AP
9	6Y5-83518-00	.BULB (12V-1.7W T6.5) .BOMBILLA (12V-1.7W T6.5)	1	1	
10	6Y5-83536-00	.SOCKET, METER .ENCASTRE DE MEDIDOR	1	1	
11	6Y5-83544-00	.PLATE, FITTING .PLACA ACCESORIA	1	1	
12	688-83664-00	.DAMPER .AMORTIGUADOR	1	1	
13	6Y5-83553-00	WIRE, LEAD (L=2.5M) CABLE CONDUCTOR (L=2.5M)	1	1	AP AP
14	1E6-82151-00	.FUSE (10A) .FUSIBLE (10A)	1	1	
15	6Y5-82117-00	WIRE, LEAD (BLACK) (L300) CABLE, CONDUCTOR (NEGRO)	1	1	AP AP
16	6R3-82553-70	EXTENSION, WIRE LEAD (L=7.0M) CABLE (L=7.0M)	1	1	AP (4P) AP (4P)

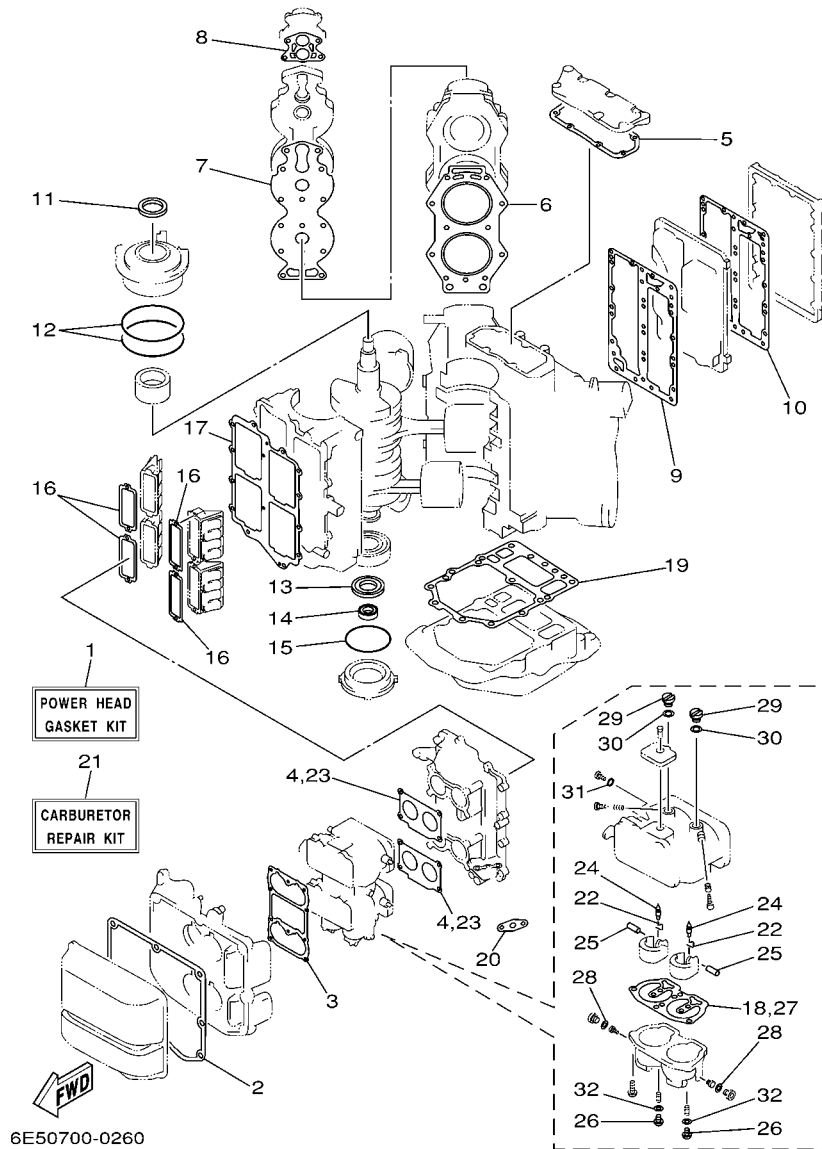

6E50700-0260

FIG. 25 REPAIR KIT 1

ESTUCHE REPARATION 1

REF. NO.	PART NO. CODIGO Nº	DESCRIPTION DESCRIPCION	6E58	6F38	REMARKS OBSERVACIONES
1	6F3-W0001-A5	POWER HEAD GASKET KIT JUEGO DE EMPAQUE	1	1	
2	6E5-14416-A1	.GASKET, AIR CLEANER .EMPAQUE	1	1	
3	6E5-14483-A1	.GASKET .EMPAQUE	1	1	
4	6E5-14198-A2	.GASKET .EMPAQUE	2	2	
5	6E5-11381-A2	.GASKET 1 .EMPAQUE 1	1	1	
6	6E5-11181-A1	.GASKET, CYLINDER HEAD 1 JUNTA, DE CULATA 1	2	2	
7	6E5-11193-A0	.GASKET, HEAD COVER 1 .EMPAQUE	2	2	
8	688-12414-A1	.GASKET, COVER .EMPAQUE	2	2	
9	6E5-41112-A1	.GASKET, EXHAUST INNER COVER .EMPAQUE	1	1	
10	6E5-41114-A0	.GASKET, EXHAUST OUTER COVER .EMPAQUE	1	1	
11	93102-40M14	.OIL SEAL .SELLO ACEITE	1	1	
12	93211-04001	.O-RING .ANILLO O	2	2	
13	93102-35M13	.OIL SEAL .SELLO ACEITE	1	1	
14	93101-22M15	.OIL SEAL .SELLO ACEITE	1	1	
15	93210-74M35	.O-RING .ANILLO O	1	1	
16	6E5-13621-A1	.GASKET, VALVE SEAT JUNTA, DE VALV.DE EMPAQUE	4	4	
17	6E5-13645-A1	.GASKET, MANIFOLD 1 .EMPAQUE	1	1	
18	64D-14384-01	.GASKET, FLOAT CHAMBER .EMPAQUE DE CAMARA DE BOIA	2	2	
19	6G5-45113-A1	.GASKET, UPPER CASING .EMPAQUE	1	1	
20	650-24431-A0	.GASKET, FUEL PUMP 1 .EMPAQUE BOMBA COMBUST 1	1	1	
21	6E5-W0093-09	CARBURETOR REPAIR KIT KIT REPARACION CARBURADOR	1	1	
22	6E5-14159-00	.CLIP .PRESILLA	2	2	
23	6E5-14198-A2	.GASKET .EMPAQUE	1	1	
24	6E5-14546-00	.VALVE, NEEDLE .VALVULA DE AGUJA	2	2	
25	6E5-14386-02	.PIN, FLOAT .PASADOR DE BOIA	2	2	
26	64D-14394-00	.VALVE, DRAIN .VALVULA DE DRENAJE	2	2	
27	64D-14384-01	.GASKET, FLOAT CHAMBER .EMPAQUE DE CAMARA DE BOIA	1	1	

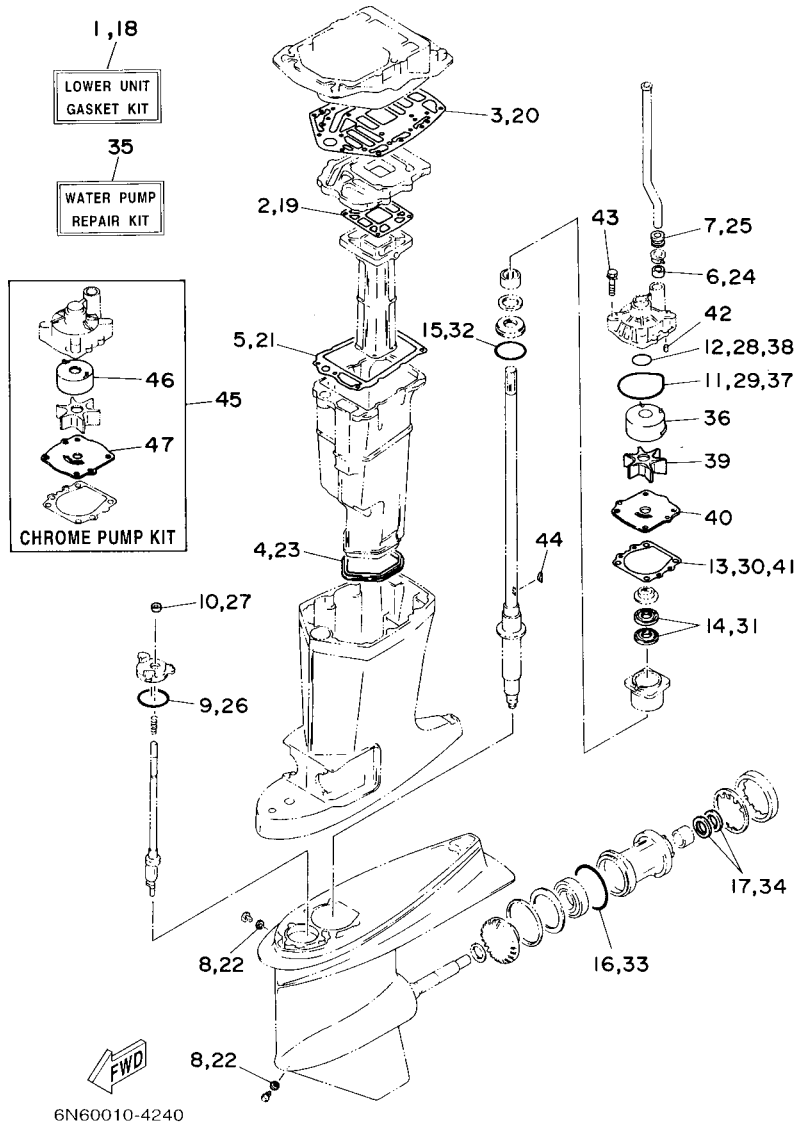

FIG. 26 REPAIR KIT 2

ESTUCHE REPARATION 2

REF. NO.	PART NO. CODIGO Nº	DESCRIPTION DESCRIPCION	6E58	6F38	REMARKS OBSERVACIONES
1	6E5-W0001-F1	LOWER UNIT GASKET KIT JUEGO DE EMPAQUE UNIDAD INFER	1		
2	6E5-41134-A0	.GASKET, EXHAUST MANIFOLD .EMPAQUE	1		
3	6G5-45114-A1	.GASKET, UPPER CASING .EMPAQUE	1		
4	6E5-45123-00	.GASKET, MUFFLER .EMPAQUE SILENCIADOR	1		
5	6E5-41135-A0	.GASKET, EXHAUST MANIFOLD .EMPAQUE	1		
6	6E5-44365-00	.DAMPER, WATER SEAL .HULE DE SELLO DE AGUA	1		
7	6E5-44366-00	.DAMPER, WATER SEAL .GOMA DEL SELLO DE AGUA	1		
8	90430-08020	.GASKET .JUNTA	2		
9	93210-58144	.O-RING .ANILLO O	1		
10	93106-09014	.OIL SEAL .SELLO ACEITE	1		
11	93210-86M38	.O-RING .ANILLO O	1		
12	93210-37160	.O-RING .ANILLO O	1		
13	6E5-44315-A0	.GASKET, WATER PUMP .EMPAQUE	1		
14	93101-28M16	.OIL SEAL .SELLO ACEITE	2		
15	93210-55M14	.O-RING .ANILLO O	1		
16	93210-86M39	.O-RING .ANILLO O	1		
17	93101-30M17	.OIL SEAL .SELLO ACEITE	2		
18	6F3-W0001-C1	LOWER UNIT GASKET KIT JUEGO DE EMPAQUE UNIDAD INFER	1		
19	6G5-41134-A1	.GASKET, EXHAUST MANIFOLD .EMPAQUE	1		
20	6G5-45114-A1	.GASKET, UPPER CASING .EMPAQUE	1		
21	6E5-41135-A0	.GASKET, EXHAUST MANIFOLD .EMPAQUE	1		
22	90430-08020	.GASKET .JUNTA	2		
23	6E5-45123-00	.GASKET, MUFFLER .EMPAQUE SILENCIADOR	1		
24	6E5-44365-00	.DAMPER, WATER SEAL .HULE DE SELLO DE AGUA	1		
25	6E5-44366-00	.DAMPER, WATER SEAL .GOMA DEL SELLO DE AGUA	1		
26	93210-58144	.O-RING .ANILLO O	1		
27	93106-09014	.OIL SEAL .SELLO ACEITE	1		

FIG. 26 REPAIR KIT 2

ESTUCHE REPARATION 2

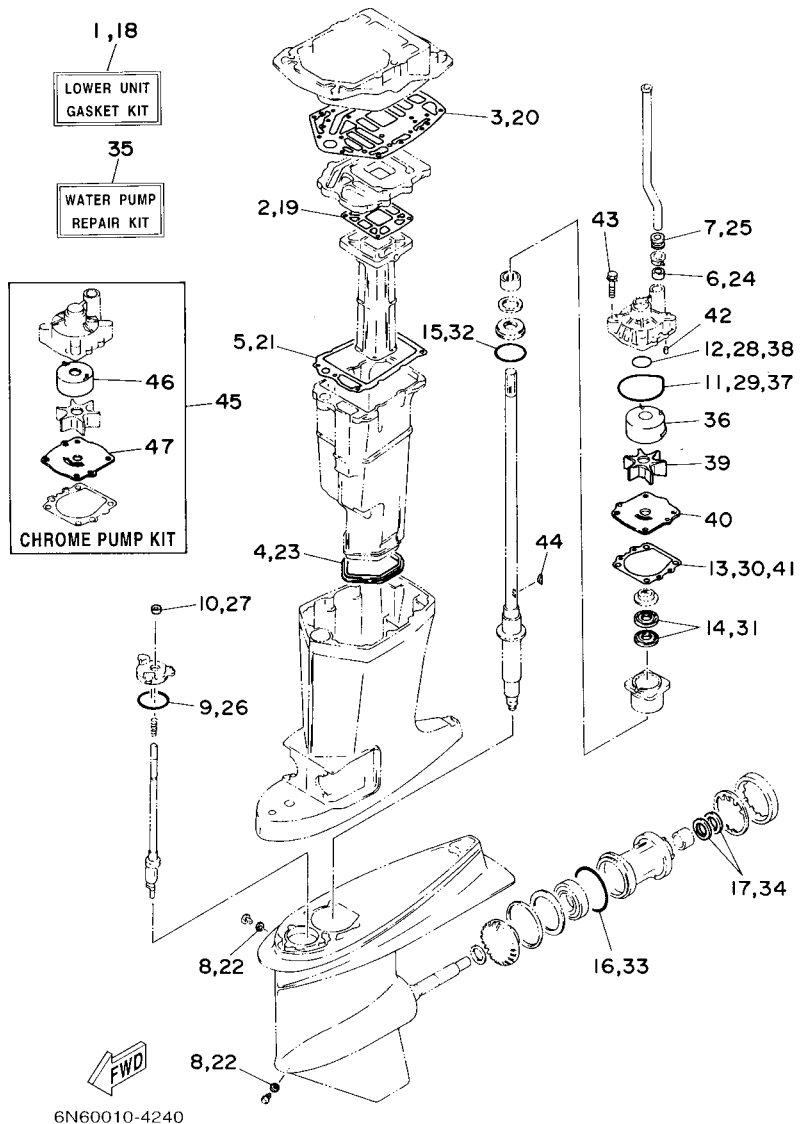

REF. NO.	PART NO. CODIGO Nº	DESCRIPTION DESCRIPCION	6E58	6F38		REMARKS OBSERVACIONES
28	93210-37160	.O-RING .ANILLO O		1		
29	93210-86M38	.O-RING .ANILLO O		1		
30	6E5-44315-A0	.GASKET, WATER PUMP .EMPAQUE		1		
31	93101-28M16	.OIL SEAL .SELLO ACEITE		2		
32	93210-55M14	.O-RING .ANILLO O		1		
33	93210-86M39	.O-RING .ANILLO O		1		
34	93101-30M17	.OIL SEAL .SELLO ACEITE		2		
35	6N6-W0078-02	WATER PUMP REPAIR KIT ESTUCHE REPARACION BOMBA AGUA	1	1		
36	61A-44322-02	.INSERT, CARTRIDGE .CARTUCHO	1	1		
37	93210-86M38	.O-RING .ANILLO O	1	1		
38	93210-37160	.O-RING .ANILLO O	1	1		
39	6E5-44352-01	.IMPELLER .IMPULSOR	1	1		
40	6E5-44323-00	.OUTER PLATE, CARTRIDGE .PLACA EXTERIOR DEL CARTUCHO	1	1		
41	6E5-44315-A0	.GASKET, WATER PUMP .EMPAQUE	1	1		
42	93606-12019	.PIN, DOWEL .PASADOR DE CLAVIJA	2	2		
43	90119-08M14	.BOLT, WITH WASHER .TORNILLO CON ARANDELA	4	4		
44	90280-04M05	.KEY, WOODRUFF .CUNA WOODRUFF	1	1		
45	6E5-W0078-3A	CHROME PUMP KIT ESTUCHE REPARACION BOMBA AGUA	1	1		
46	6R3-44322-42	.INSERT, CARTRIDGE .CARTUCHO	1	1		
47	6E5-44323-40	.OUTER PLATE, CARTRIDGE .PLACA EXTERIOR DEL CARTUCHO	1	1		

NUMERICAL INDEX
INDICE NUMERICO

PART NO. CODIGO N°	REF. NO.	PART NO. CODIGO N°	REF. NO.	PART NO. CODIGO N°	REF. NO.	PART NO. CODIGO N°	REF. NO.	PART NO. CODIGO N°	REF. NO.	PART NO. CODIGO N°	REF. NO.
6L1-11111-00-1S	4 - 1	6E5-13641-03-1S	5 - 6	6E5-14737-00	18 - 30	6E5-24435-01	7 - 28	6E5-42510-25-8D	15 - 10	64E-43139-10	15 - 1
6E5-11111-10-1S	4 - 1	6E5-13645-A1	5 - 13	64D-1492E-88	6 - 12	6E5-24444-01	7 - 25	6F3-42610-40-4D	1 - 1	6G5-43144-00	14 - 27
6E5-11119-01	2 - 18		25 - 17	64D-1492E-90	6 - 12	61A-24469-00	7 - 11	6E5-42610-80-4D	1 - 1	6G5-43148-00	14 - 32
6E5-11181-A1	4 - 2	6E5-14159-00	6 - 7	64D-1492F-39	6 - 9	6E5-24471-01	7 - 27	6E5-42613-01-4D	1 - 15	6G5-43181-02	14 - 29
	25 - 6		25 - 22	6E5-1492F-41	6 - 9	6E5-24486-00	7 - 37	6E5-42615-00	1 - 14	6G5-43185-02	14 - 30
6E5-11191-01-1S	4 - 4	6E5-14198-A2	5 - 18	61A-1492H-12	6 - 14	6E5-24492-00	7 - 36	6E5-42617-00	1 - 11	64E-43311-10-8D	14 - 22
6E5-11193-A0	4 - 5		25 - 4	61U-14959-00	6 - 10	61A-24521-00	7 - 6	6E5-42619-00	1 - 12	64E-43311-20-8D	14 - 22
	25 - 7		25 - 23		25 - 32	65L-24531-01	7 - 7	6E5-42627-00	1 - 13	61A-43376-00	15 - 8
6R3-1131M-01	2 - 14	6E5-14223-00	6 - 21	6E5-14979-00	6 - 19	60H-24558-00	7 - 12	6E5-42647-00-94	1 - 2	64E-43800-04-4D	16 - 1
6E5-11325-00	2 - 12	6L1-14301-05	6 - 1		25 - 30	61A-24560-04	7 - 5	6E5-42649-01-94	1 - 3	64E-43802-00	17 - 8
6E5-11370-01	5 - 8	6E5-14301-17	6 - 1	6J8-14995-00	6 - 26	61A-24563-00	7 - 10	688-42652-00	1 - 8	64E-43805-00	17 - 37
6E5-11371-00-1S	2 - 24	6L1-14302-05	6 - 2		25 - 31	61A-24564-00	7 - 8	6E5-42652-00	1 - 7	64E-4380F-00	17 - 33
6G5-11372-00-1S	4 - 24	6E5-14302-17	6 - 2	6N6-15100-01-1S	2 - 2	61U-24566-01	7 - 16	663-42662-00	1 - 4	64E-4380J-00	17 - 30
6E5-11372-01	2 - 5	6E5-14321-00	6 - 16	6N7-15100-01-1S	2 - 2	61A-24577-01	7 - 9	6E5-42677-40	1 - 18	64E-43810-01	16 - 6
624-11379-00	2 - 3	6E5-14323-03	6 - 20	6E5-15163-00-1S	3 - 3	6YJ-24610-01	21 - 2	6F3-42677-40	1 - 18	64E-43811-01	16 - 7
6E5-11381-A2	2 - 25	6E5-14324-00	6 - 25	6G5-15359-00-94	3 - 11	6E5-41111-00-1S	4 - 12	6N7-42678-30	1 - 22	6E5-43814-02	16 - 14
	25 - 5	6A0-14325-00	7 - 34	6YJ-24167-00	21 - 7	6L1-41111-00-1S	4 - 12	6E5-42678-31	1 - 19	64E-43816-00	17 - 17
6G5-11382-A1	4 - 23	6E5-14328-01	6 - 18	6YJ-24201-00	21 - 1	6E5-41112-A1	4 - 13	6F3-42678-31	1 - 19	64E-43817-00	16 - 5
6R3-11397-01	2 - 15		25 - 29	6YJ-24201-10	21 - 1		25 - 9	6E5-4267A-31	1 - 21	64E-43817-10	17 - 19
6N7-11411-01	3 - 1	6J8-14334-00	6 - 17	6YJ-24260-00	21 - 3	6N7-41113-00-1S	4 - 15	6N7-42681-30	1 - 23	6BC-43818-00	16 - 34
6E5-11447-00	3 - 2	64D-14381-00	6 - 4	6Y1-24260-12	21 - 3	6E5-41114-A0	4 - 14	6N7-42682-30	1 - 24	64E-4381G-00	16 - 28
663-11518-01	2 - 4	61A-14383-01	6 - 15	6Y1-24268-00	21 - 6		25 - 10	648-42715-00	13 - 49	64E-43820-01	16 - 16
64D-11603-02	3 - 17	64D-14384-01	6 - 3	6E5-24304-10	7 - 1	6G5-41131-01-5B	18 - 21	6E5-42716-00	12 - 36	64E-43821-01	16 - 17
	3 - 19		25 - 18	6E5-24305-06	21 - 9	6L1-41132-00-5B	18 - 25	6E5-42724-00	18 - 11	64E-43822-00	16 - 18
64D-11604-02	3 - 17		25 - 27	6Y2-24305-06	21 - 11	6E5-41132-10-5B	18 - 25	6E5-42725-00	12 - 15	64E-43825-02	16 - 2
	3 - 19	6E5-14385-02	6 - 5	6Y2-24306-0B	21 - 8	6E5-41134-A0	18 - 26	688-42726-10	12 - 24	64E-43827-00	17 - 22
64D-11605-02	3 - 17	6E5-14386-02	6 - 8	6E5-24312-00	4 - 17		26 - 2	6E5-42738-01-5B	12 - 16	64E-43828-00	16 - 23
	3 - 19		25 - 25	61U-24313-00	7 - 3	6G5-41134-A1	18 - 26	6E5-42741-01-4D	12 - 26	64E-43829-00	16 - 24
6R5-11631-11-93	3 - 16	64D-14394-00	6 - 11	61U-24314-00	7 - 21		26 - 19	6H4-42748-00	12 - 2	64E-4382G-00	16 - 30
6R5-11633-10	3 - 20		25 - 26	6G5-24316-10	7 - 40	6E5-41135-A0	18 - 33	6E5-42761-00-1S	2 - 20	64E-43830-00	17 - 4
6R5-11634-10	3 - 21	647-14395-60	5 - 29	6G5-24318-10	7 - 44		26 - 5	6E5-42762-00-1S	2 - 21	64E-43831-00	17 - 2
6R5-11635-11	3 - 16	6E5-14398-00	6 - 13	6G5-24319-10	7 - 45		26 - 21	6E5-42769-00	18 - 5	64E-43841-00	17 - 7
6R5-11636-11	3 - 16		25 - 28	6Y1-24329-00	21 - 5	6G5-41137-02-94	18 - 10	6E5-42771-01-4D	12 - 27	64E-43843-00	17 - 6
6R5-11642-11-93	3 - 18	6E5-14416-A1	5 - 35	6E5-24351-01	21 - 14	6E5-41213-00	13 - 32	6G5-42791-00	12 - 42	64E-43843-10	17 - 38
6R5-11645-11	3 - 18		25 - 2	61J-24360-11	21 - 16	6E5-41217-01	5 - 20	6K7-42791-00	12 - 42	64E-4384J-00	16 - 19
6R5-11646-11	3 - 18	6E5-14417-10-94	5 - 25	6E5-24367-01	12 - 30	662-41237-01	13 - 25	6L1-42791-00	12 - 42	64E-43850-00	17 - 15
6R5-11650-10	3 - 22	6E5-14418-00	5 - 33	6E5-24367-10	12 - 33		13 - 31	6G5-42791-10	12 - 42	64E-43851-00	17 - 11
6E5-12411-30	4 - 7	6E5-1441K-00	5 - 34	6E5-24376-10	7 - 43	6E5-41256-01	5 - 21	6R3-42791-41	18 - 2	64E-43855-00	17 - 14
688-12412-00	4 - 8	6E5-14483-A1	5 - 30	650-24378-00	4 - 16	661-41262-02	5 - 22	6R3-42792-41	18 - 3	64E-43858-00	17 - 12
6G5-12413-00-1S	4 - 9		25 - 3	6E5-24410-04	7 - 24	6E5-41271-02	5 - 23	688-42815-01-4D	12 - 3		17 - 18
688-12414-A1	4 - 10	624-14485-00	5 - 7	6E5-24411-01	7 - 29	689-41273-00	5 - 24	688-42816-00	12 - 4	6E5-43858-00	16 - 29
	25 - 8		5 - 26	6E5-24412-11	7 - 32	688-41611-00	8 - 9	6E5-42816-00	12 - 9	72X-43858-00	17 - 5
60H-12416-00	4 - 20	6E5-14485-00	5 - 27	6E5-24413-01	7 - 26	688-41612-00	8 - 10	6E5-42816-01	12 - 10	64E-43859-00	17 - 13
6E5-12576-00	4 - 26	6E5-14488-00	8 - 21	6A0-24421-01	7 - 33	6E5-41631-01-1S	13 - 10	6E5-42817-01-4D	12 - 8	64E-43860-00	17 - 20
6G5-12581-00	18 - 12	6E5-14527-01	6 - 23	6E5-24423-00	7 - 31	6E5-41632-02-1S	13 - 6	64E-43111-02-8D	14 - 1	6E5-43862-00	16 - 11
6E5-13610-00	5 - 1	6E5-14546-00	6 - 6	648-24424-00	7 - 30	688-41636-00	13 - 29	64E-43112-02-8D	14 - 9		16 - 15
6E5-13621-A1	5 - 3		25 - 24	650-24431-A0	7 - 38	6E5-41636-01	13 - 23	64E-43126-00	14 - 37	6G5-43863-00	17 - 10
	25 - 16	6E5-14711-01-5B	18 - 29		25 - 20	6E5-42510-05-8D	15 - 10	64E-43131-01	14 - 15	6E5-43864-00	16 - 21

NUMERICAL INDEX
INDICE NUMERICO

PART NO. CODIGO N°	REF. NO.	PART NO. CODIGO N°	REF. NO.	PART NO. CODIGO N°	REF. NO.	PART NO. CODIGO N°	REF. NO.	PART NO. CODIGO N°	REF. NO.	PART NO. CODIGO N°	REF. NO.
6G5-43864-00	16 - 20	6E5-44352-01	19 - 28	6E5-45371-10	20 - 28	6E5-45952-00-EL	20 - 26	703-48271-00	23 - 60	6G5-82119-00	10 - 11
64E-43865-00	17 - 16		26 - 39	688-45375-00	20 - 9	6E5-45954-00-EL	20 - 26	703-48281-00	23 - 31	6E5-82147-00	14 - 26
6G5-43865-00	17 - 35	6E5-44361-00	20 - 2	663-45376-00-94	20 - 8	6E5-45956-00-EL	20 - 26	703-48282-00	23 - 32	6E5-82147-20	14 - 26
64E-43866-00	16 - 10	6E5-44361-20	20 - 2	6E5-45378-00	19 - 10	688-45970-03-98	20 - 26	703-48284-00	23 - 52	6E5-82148-00	14 - 6
64E-43867-00	16 - 9	6E5-44365-00	20 - 3	688-45383-02	19 - 68	6E5-45970-10	20 - 27	701-48287-00	23 - 42		14 - 10
64E-43868-00	17 - 3		20 - 19	688-45384-00	19 - 69	688-45972-02-98	20 - 26	703-48291-10	23 - 39	6E5-82149-00	15 - 19
64E-43869-00	16 - 27		26 - 6	6E5-45501-01	19 - 43	6E5-45972-10	20 - 27	703-48293-10	23 - 41	1E6-82151-00	24 - 14
6H1-4386K-10	17 - 29		26 - 24	6E5-45501-21	19 - 43	688-45974-02-98	20 - 26	701-48320-40	22 - 2	663-82151-00	10 - 26
6E5-43872-00	16 - 13	6E5-44366-00	20 - 1	61A-45527-00	19 - 23	6E5-45974-10	20 - 27	701-48320-50	22 - 2	6G5-82152-00	10 - 1
64E-43873-00	17 - 24		26 - 7	6E5-45536-00	19 - 9	688-45976-01-98	20 - 26	701-48320-80	22 - 2	6A0-82317-00	8 - 18
6E5-43874-01	16 - 22		26 - 25	61A-45538-00	19 - 20	6E5-45976-10	20 - 27	6E5-48344-00	13 - 7		9 - 2
64E-43875-00	17 - 25	6E5-44391-00	12 - 14	6E5-45551-02	19 - 44	6E5-45978-10	20 - 27		13 - 42	6G5-82317-00	8 - 17
64E-43879-00	17 - 27	6E5-44511-00-5B	15 - 38	6E5-45560-01	19 - 46	688-45978-60-98	20 - 26	703-48345-01	23 - 19	663-82370-01	10 - 5
64E-43879-10	17 - 26	6E5-44514-00-94	15 - 31	6E5-45567-01	19 - 5	6E5-45987-01	20 - 21	703-48358-00	23 - 20	703-82510-43	23 - 44
64E-4387A-00	17 - 23	6G5-44526-00	14 - 3	6E5-45567-10	19 - 5	6E5-45994-10	20 - 29	6E5-48531-00	13 - 1	662-82519-00	10 - 35
64E-43880-02	17 - 28	68F-44533-00	2 - 22	6E5-45567-20	19 - 5	688-45997-01	20 - 22	6E5-48538-00	13 - 2	6R3-82519-00	10 - 29
64E-43883-00	16 - 12	6G5-44551-01-8D	15 - 13	6E5-45567-30	19 - 5	703-48152-00	23 - 57	6E5-81320-00	8 - 13	703-82531-00	23 - 46
64E-4388E-00	16 - 26	6E5-44552-01-94	15 - 24	6E5-45567-40	19 - 5	703-48153-00	23 - 3	6E5-81337-01	8 - 16	6E5-82531-10	10 - 32
64E-4388E-10	17 - 1	6E5-44553-01-8D	15 - 27	6E5-45567-50	19 - 5	703-48189-00	23 - 17	6N7-81800-10	11 - 1	703-82540-00	23 - 50
64E-4388J-00	16 - 3	6E5-44555-00-94	15 - 16	6E5-45567-60	19 - 5	703-48198-00	23 - 14	6N7-81801-00	11 - 8	6R3-82553-70	24 - 16
64E-43891-00	17 - 31	663-44575-00	15 - 37	6E5-45571-01	19 - 60	703-48205-17	22 - 1	6N7-81807-00	11 - 11	682-82556-00	23 - 48
64E-43892-00	17 - 34	6E5-44575-00	15 - 15	6E5-45576-00	19 - 61		23 - 1	61A-81809-00	11 - 3	688-82560-10	10 - 24
6E5-43896-00	17 - 9	6E5-45111-02-8D	18 - 1	6L6-45577-00	19 - 65	703-48211-01	23 - 61	6N7-81810-00	11 - 5	703-82563-02	23 - 55
64E-43897-00	16 - 25	6E5-45111-23-8D	18 - 1	6L6-45577-10	19 - 65	703-48212-00	23 - 58	6N7-81813-00	11 - 9	688-82575-01	23 - 47
64E-43898-00	16 - 8	6G5-45113-A1	18 - 14	6L6-45577-20	19 - 65	703-48213-00	23 - 59	6N7-81820-10	11 - 10	703-82577-00	23 - 45
6E5-44117-00-1S	13 - 36		25 - 19	6L6-45577-30	19 - 65	703-48215-00	23 - 43	6E5-81822-02-98	11 - 19	6E5-82588-00	12 - 37
6E5-44118-01-94	13 - 44	6G5-45114-A1	18 - 22	6L6-45577-40	19 - 65	703-48219-00	23 - 30	61A-81824-00	11 - 4	688-8258A-20	23 - 49
6E5-44120-03	13 - 51		26 - 3	6L6-45577-50	19 - 65	703-48221-00	23 - 56	6K7-81826-11	11 - 14	6E5-82590-04	10 - 25
6E5-44120-23	13 - 51		26 - 20	6L6-45577-60	19 - 65	703-48222-00	23 - 27	6E5-8182A-10	11 - 17	703-82591-00	23 - 53
68F-44121-00	13 - 38	663-45119-00	14 - 14	6E5-45587-01	19 - 37	703-48223-00	23 - 28	6E5-8182E-10	11 - 15	703-82592-00	23 - 54
6E5-44122-00	13 - 39		14 - 25	6E5-45587-10	19 - 37	703-48225-00	23 - 29	6E5-8182F-10	11 - 16	688-82594-00	12 - 40
6E5-44150-02	19 - 17	6E5-45123-00	18 - 32	6E5-45587-20	19 - 37	703-48226-00	23 - 26	6K7-8182G-10	11 - 6	6E5-82594-00	12 - 41
688-44194-00	13 - 14		26 - 4	6E5-45587-30	19 - 37	703-48227-00	23 - 24	6E5-8182K-10	11 - 18	703-82594-00	23 - 25
	13 - 28		26 - 23	6E5-45587-40	19 - 37	703-48232-00	23 - 62	6N7-81830-00	11 - 13	703-83383-02	23 - 51
61A-44311-01	19 - 24	6E5-45155-00	18 - 4	6E5-45587-50	19 - 37	703-48234-00	23 - 18	6N7-81840-00	11 - 7	6Y5-83514-00	24 - 5
6E5-44312-00	20 - 20	688-45214-02	20 - 10	6E5-45587-60	19 - 37	703-48235-00	23 - 4	6N7-81850-10	11 - 2	6Y5-83517-00	24 - 2
6E5-44315-A0	19 - 31	688-45215-02	20 - 11	6E5-45611-01	19 - 48	703-48236-00	23 - 16	6N7-81857-00	11 - 12	6Y5-83518-00	24 - 9
	26 - 13	6G5-45251-02	14 - 2	6E5-45631-01	19 - 56	703-48238-00	23 - 22	61A-81941-00	10 - 6	6Y5-83523-00	24 - 4
	26 - 30	6E5-45300-17-8D	19 - 1	6E5-45633-01	19 - 57	703-48243-00	23 - 15	6E5-81948-22	10 - 13	6Y5-83536-00	24 - 10
	26 - 41	6E5-45300-27-8D	19 - 1	6E5-45634-01	19 - 50	703-48244-00	23 - 21	6E5-81950-00	10 - 8	6Y5-83536-40	24 - 3
61A-44322-02	19 - 25	6E5-45301-05-8D	19 - 2	6E5-45641-03	19 - 49	703-48245-00	23 - 11	689-81952-10	10 - 7	6Y7-83540-20	24 - 1
	26 - 36	6E5-45318-00	18 - 36	688-45930-02-98	20 - 26	703-48246-00	23 - 23	6E5-8195A-00	10 - 9	6Y5-83544-00	24 - 11
6R3-44322-42	19 - 25	6E5-45321-00	19 - 13	688-45932-60-98	20 - 26	701-48248-00	23 - 13	6H0-81960-00	9 - 13	6Y5-83553-00	24 - 13
	26 - 46	6E5-45331-00-94	19 - 34	6E5-45941-00-EL	20 - 26	703-48252-00	23 - 12	6E5-81961-00	9 - 18	6N7-83557-00	10 - 16
6E5-44323-00	19 - 30	6E5-45332-00-94	19 - 58	6E5-45943-00-EL	20 - 26	703-48261-01	23 - 2	6E5-82105-12	10 - 27	6E5-83558-00	20 - 17
	26 - 40	688-45341-10	19 - 7	6E5-45945-01-EL	20 - 26	703-48264-00	23 - 6	6E5-82116-00	10 - 12	6E5-83558-10	19 - 12
6E5-44323-40	19 - 30	6E5-45344-00	19 - 40	6E5-45947-00-EL	20 - 26	703-48265-00	23 - 9	6Y5-82117-00	24 - 15	6A1-83625-41	8 - 22
	26 - 47	6E5-45371-01	20 - 14	6E5-45949-00-EL	20 - 26	703-48268-00	23 - 5	6E5-82117-01	10 - 28	688-83664-00	24 - 12

NUMERICAL INDEX
INDICE NUMERICO

PART NO. CODIGO N°	REF. NO.	PART NO. CODIGO N°	REF. NO.	PART NO. CODIGO N°	REF. NO.	PART NO. CODIGO N°	REF. NO.	PART NO. CODIGO N°	REF. NO.	PART NO. CODIGO N°	REF. NO.
6Y7-83670-00	24 - 8	90119-08077	18 - 16	90202-08M20	13 - 40	90445-07MF0	20 - 16	92990-06100	9 - 9	93101-28M16	26 - 31
64E-83672-02	15 - 3	90119-08078	18 - 9	90202-12092	13 - 20	90445-13M00	21 - 15	92990-06200	13 - 8	93101-30M17	19 - 63
72X-85075-L0	17 - 21	90119-08M14	19 - 33	90202-16061	13 - 54	90445-13M01	21 - 13	92990-06600	9 - 10		26 - 17
6E5-85510-01	8 - 2		26 - 43	90202-26M18	15 - 33	90446-15M07	7 - 48		12 - 32		26 - 34
6N7-85537-00	9 - 11	90119-08M22	12 - 23	90202-32M19	15 - 17	90464-12M00	8 - 12		12 - 35	93102-08M43	17 - 36
6E5-85540-00	9 - 7	90119-08M57	11 - 22	90202-40M47	15 - 7	90465-05M87	10 - 39	92990-08600	11 - 23	93102-35M13	3 - 12
6N7-85542-01-1S	9 - 1	90119-08M76	11 - 20	90206-10M04	13 - 34	90465-06M86	2 - 27		23 - 34		25 - 13
6E5-85550-00	8 - 1	90119-08M77	11 - 21	90206-13M10	12 - 6		5 - 15	92990-18200	20 - 23	93102-40M14	3 - 5
6R3-85570-01	10 - 2	90119-08M79	18 - 15		12 - 12		9 - 19	92995-06100	7 - 14		25 - 11
6E5-85580-00	8 - 3	90119-08M94	2 - 10	90206-22M19	19 - 22	90465-08M63	14 - 23		14 - 5	93106-09014	19 - 15
6E5-86110-02	10 - 18	90119-08MA3	2 - 19	90249-06M19	14 - 33	90465-08M89	10 - 40	92995-06600	1 - 10		26 - 10
6E5-86116-01	10 - 19	90119-08MA8	4 - 3	90250-08M07	19 - 55	90465-11M10	7 - 4		1 - 17		26 - 27
6G5-87149-10	10 - 10	90119-10M89	20 - 7	90266-06009	1 - 5		7 - 22		5 - 17	93210-03261	10 - 23
6F3-W0001-A5	25 - 1	90152-05M07	20 - 12	90266-06M02	1 - 6		7 - 18		7 - 18	93210-08287	21 - 10
6F3-W0001-C1	26 - 18	90157-05M19	21 - 4	90280-04M05	19 - 29		7 - 41		7 - 20		21 - 12
6E5-W0001-F1	26 - 1	90157-06013	13 - 11		26 - 44		7 - 42		8 - 15	93210-09165	13 - 52
6E5-W0004-00	5 - 2		13 - 26	90280-05015	8 - 4		7 - 46		9 - 6	93210-10M74	16 - 4
6N7-W0070-30	1 - 20	90157-06M01	12 - 31	90282-04010	19 - 67		7 - 47		9 - 21	93210-37160	19 - 27
6N6-W0078-02	26 - 35		12 - 34	90340-08002	19 - 6		14 - 21		10 - 4		26 - 12
6E5-W0078-3A	26 - 45	90159-06M11	9 - 12	90340-14M00	2 - 6		15 - 5		10 - 15		26 - 28
6E5-W0090-56-1S	2 - 1	90170-16M01	19 - 45	90386-06M12	13 - 43		20 - 18		10 - 22		26 - 38
6F3-W0090-67-1S	2 - 1	90170-20137	8 - 6	90386-10M16	14 - 31	90465-12M25	10 - 38		10 - 31	93210-37MH7	15 - 6
6E5-W0093-09	25 - 21	90171-18M04	20 - 24	90386-12089	13 - 17	90465-13M18	4 - 27		10 - 34	93210-55M14	19 - 39
656-W2810-02	7 - 49	90179-06066	15 - 30	90386-13M38	12 - 5		10 - 17		10 - 37		26 - 15
6E5-W4271-05-4D	12 - 1	90179-06M28	5 - 19		12 - 11	90467-08004	4 - 18		12 - 18		26 - 32
90101-12M03	14 - 40	90183-05M02	18 - 31	90386-16M66	13 - 53	90468-18008	13 - 41		12 - 29	93210-58144	19 - 14
90105-10M00	20 - 15	90185-05002	20 - 13	90386-22M13	13 - 19	90480-10M36	12 - 25		12 - 39		26 - 9
90105-10M20	2 - 9	90185-06M07	13 - 9	90386-22M98	14 - 38	90480-20M05	4 - 22		14 - 8		26 - 26
90109-08022	3 - 23	90185-12M12	15 - 36		16 - 35	90480-22M15	12 - 19		14 - 12	93210-74M35	3 - 14
90109-12007	15 - 35	90185-22M11	14 - 20	90386-25M31	14 - 18	90501-11M10	19 - 19		18 - 7		25 - 15
90109-14M34	15 - 20	90201-06068	7 - 15	90386-38M32	15 - 12	90501-12082	13 - 48	92995-08100	13 - 5	93210-86M38	19 - 26
90116-06M30	5 - 12	90201-06M05	9 - 17	90387-06119	8 - 19	90501-16M11	4 - 21		14 - 17		26 - 11
90116-08026	2 - 11	90201-08M13	13 - 21		9 - 3	90501-16M12	13 - 12		18 - 18		26 - 29
90119-06M09	12 - 7	90201-08M23	13 - 16	90387-06M29	13 - 33	90501-16M28	15 - 28		18 - 20		26 - 37
	12 - 13	90201-08M54	12 - 21	90387-06M77	9 - 16	90501-16M37	19 - 51	92995-08600	11 - 25	93210-86M39	19 - 64
90119-06M10	19 - 16	90201-10060	16 - 31	90387-08M16	13 - 18	90506-14M24	14 - 36		18 - 24		26 - 16
90119-06M31	5 - 36	90201-12M05	14 - 42	90387-08M37	12 - 20	90508-29M12	13 - 22		18 - 28		26 - 33
90119-06M59	9 - 4	90201-13M01	14 - 41	90387-10M05	14 - 34	91490-40030	20 - 25		18 - 35	93211-04001	3 - 6
90119-06M65	8 - 20	90201-14M56	15 - 34	90430-08020	19 - 8	91609-30010	10 - 20		19 - 42		25 - 12
90119-06MA2	2 - 23	90201-15M58	15 - 21		26 - 8	91690-30012	13 - 3	92995-10100	15 - 26	93306-208U0	3 - 9
	2 - 26	90201-16M55	15 - 18		26 - 22	91690-30020	14 - 35		15 - 40		19 - 59
	3 - 7	90201-21M18	8 - 5	90430-14115	2 - 7	92903-06600	2 - 17		20 - 6	93310-32337	3 - 24
	3 - 15	90201-22M01	19 - 21	90445-07M23	5 - 28		5 - 32	92995-10600	16 - 33	93310-836U0	3 - 26
	13 - 37	90201-23M01	3 - 25	90445-07M24	5 - 10		8 - 8	92995-14600	15 - 23	93310-954U1	3 - 8
90119-06MA3	5 - 14	90201-26M57	15 - 32	90445-07M28	5 - 9		9 - 15	93101-22M15	3 - 13	93311-940U3	3 - 4
90119-06MA4	4 - 6	90201-26M59	14 - 19	90445-07M46	5 - 11	92903-08600	13 - 46		25 - 14	93315-425U7	19 - 47
90119-06MA5	4 - 19	90201-30M92	19 - 66	90445-07ME8	19 - 11	92990-05100	24 - 7	93101-28M16	19 - 35	93315-43061	19 - 62
90119-06MA6	4 - 11	90201-38M60	15 - 11	90445-07ME9	19 - 11	92990-05600	5 - 5		26 - 14	93315-628U9	19 - 3

NUMERICAL INDEX
INDICE NUMERICO

PART NO. CODIGO N°	REF. NO.	PART NO. CODIGO N°	REF. NO.	PART NO. CODIGO N°	REF. NO.	PART NO. CODIGO N°	REF. NO.	PART NO. CODIGO N°	REF. NO.	PART NO. CODIGO N°	REF. NO.
93317-330U2	19 - 36	97095-06010	14 - 28	98580-04006	23 - 36						
93332-000U7	19 - 4		18 - 6	98580-04010	23 - 35						
93341-930V2	19 - 38	97095-06012	5 - 16	98580-05010	23 - 37						
93410-16006	13 - 55		9 - 5	98780-04015	2 - 13						
93410-22M11	14 - 39		9 - 20	99001-08600	19 - 18						
93410-37M04	15 - 14		10 - 30								
93410-40M03	3 - 10		10 - 33								
93420-36M01	18 - 37		10 - 36								
93430-06024	23 - 10	97095-06014	7 - 17								
93501-04M02	13 - 47	97095-06016	1 - 9								
93503-16003	19 - 54		1 - 16								
93507-32009	19 - 52		7 - 13								
93511-32017	19 - 53		7 - 19								
93606-12019	19 - 32		10 - 14								
	26 - 42		10 - 21								
93608-12063	2 - 8		12 - 17								
93608-12M05	18 - 8	97095-06020	10 - 3								
	18 - 13		12 - 28								
	20 - 4		12 - 38								
93700-06M03	13 - 50	97095-06025	13 - 35								
	14 - 13	97095-06028	7 - 2								
	14 - 24	97095-06030	14 - 4								
94702-00160	4 - 28	97095-08016	11 - 24								
94702-00247	4 - 28	97095-08020	13 - 4								
94702-00309	4 - 28		14 - 16								
94702-00317	4 - 28	97095-08025	19 - 41								
95303-06600	13 - 13	97095-08030	18 - 23								
	13 - 27	97095-08045	18 - 17								
95380-03600	7 - 35		18 - 27								
95380-05600	13 - 24		18 - 34								
	13 - 30	97095-10045	15 - 25								
	23 - 7		15 - 39								
	24 - 6	97380-05025	23 - 8								
95380-06600	23 - 40	97380-08030	23 - 33								
95380-08700	18 - 19	97595-06420	4 - 25								
95380-12600	14 - 43	97595-06550	7 - 39								
95380-14800	15 - 22	97607-04310	17 - 32								
95780-10300	15 - 9	97880-05025	5 - 4								
97013-06016	2 - 16	97880-06018	8 - 11								
97013-06020	5 - 31	97880-06040	9 - 8								
97013-06045	9 - 14	97885-06010	8 - 14								
97013-06060	8 - 7	97885-06012	14 - 11								
97013-08030	13 - 45	97885-06016	15 - 4								
97013-08045	13 - 15		15 - 29								
97075-08035	12 - 22	97980-05108	6 - 24								
97075-10030	16 - 32	97980-05116	6 - 22								
97075-10045	20 - 5	97980-05230	15 - 2								
97095-06010	14 - 7	98580-03015	23 - 38								