



**PARTS
CATALOGUE
CATALOGO
DE REPUESTOS**

(E)40XMH'07 (66TC)

E40XWH'07 (66TD)

(E)40XW'07 (66TD)

(E)40XWT'07 (66TD)

(E)40XMH/E40XWH
(E)40XW/(E)40XWT
PARTS CATALOGUE
©2006 by Yamaha Motor Co., Ltd.
1st edition, October 2006
All rights reserved.
Any reprinting or unauthorized use
without the written permission of
Yamaha Motor Co., Ltd.
is expressly prohibited.
Printed in Japan.

(E)40XMH/E40XWH
(E)40XW/(E)40XWT
CATALOGO DE REPUESTOS
©2006 por Yamaha Motor Co., Ltd.
1ª edición, octubre 2006
Todos los derechos reservados.
Toda reproducción o uso no autorizado
sin el consentimiento escrito de
Yamaha Motor Co., Ltd.
quedan expresamente prohibidos
Impreso en Japón.

FOREWORD

This Parts Catalogue is related to the parts for the model(s) on the cover page. When you are ordering replacement parts, please refer to this Parts Catalogue and quote both part numbers and part names correctly.

1. Modifications or additions which have been made after the issue of the Parts Catalogue will be announced in the Parts News.
It is advisable that you make the necessary corrections to the Parts Catalogue according to the Parts News.

2. Abbreviations

The following abbreviations are used in this Parts Catalogue.

“UR” Use specified parts number.

“UN” Use as many as needed.

“AP” Alternate Parts

“LM” Locally Made (Parts need to be ordered locally)

“F#” Frame No. (Applicable machine No.)

“O/S” Over Size

3. The number of components for assembly

- Parts, which are to be supplied in an assembly, are listed with a dot (.) in front of the part name as shown below.
- The numeral appearing to the right of each component part indicates the quantity of parts for each assembly unit.

PART NO.	DESCRIPTION	Q'TY	REMARKS
2F5-83310-60	FRONT FLASHER LIGHT ASSY	2	
115-83311-60	.BULB (6V-18W)	1	

4. Applicable colours of graphics are represented in the “REMARKS” as shown below.

PART NO.	DESCRIPTION	Q'TY	REMARKS
2N4-24110-00-X5	FUEL TANK COMP.	2	MXR
3J1-24240-10	.GRAPHIC, FUEL TANK	1	FOR MXR

5. Note that the illustrations for reference in finding parts numbers are not to be used for assembling. When assembling, please use the applicable service manual.

6. The asterisk (*) before a reference number indicates modified items after the first edition.

7. Applicable Serial No.

Engine Serial No.

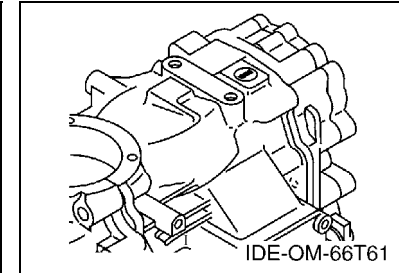
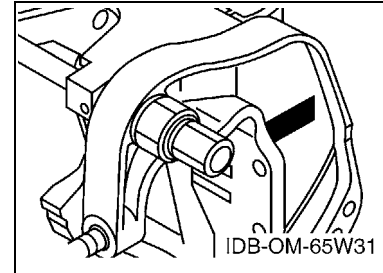

8. Applicable Engine Starting Serial No.

Model	Serial No.	Model	Serial No.
(E)40X	66TK-1041311		

9. Applicable Colour Code

Abbreviation	Colour Name	Colour Code
DBNM2	DARK BLUISH GRAY METALLIC 2	004D

10. Quantity Column Information

Column No.	Name Of Q'ty Column	Applicable Model
1	MH	40XMH,E40XMH
2	WH	E40XWH
3	W	40XW,E40XW
4	WT	40XWT,E40XWT

PROLOGO

Este catálogo de repuestos corresponde a las piezas para el o los modelos que figuran en la página de portada. Al formular el pedido de repuestos, se ruega citar este catálogo y especificar correctamente el número y el nombre de las piezas.

- Las modificaciones y agregados que se hayan realizado después de la edición de este Catálogo de Repuestos, serán anunciados en las Informaciones de Recambios. Es recomendable que se hagan las correcciones necesarias en el Catálogo de Repuestos de acuerdo con las Informaciones de Recambios.

2. Abreviaciones

En este. Catálogo de Repuestos se emplean las siguientes abreviaciones.

- “UR” Usar el número de partes especificado
- “UN” Usar la cantidad necesaria
- “AP” Piezas sustitutivas
- “LM” Fabricación local (Hay que pedir los repuestos en las cercanías)
- “F#” N° de bastidor (N° aplicable a la máquina)
- “O/S” Sobredimensionado

3. La cantidad de componentes para el montaje

- Los componentes, suministrados como conjunto, se describen con un punto (.) que precede al nombre del parte como se indica a continuación.
- La numeración que aparece a la derecha de cada descripción indica la cantidad de partes por cada unidad de conjunto.

CODIGO N°	DESCRIPCION	CANT.	OBSERVACIONES
2F5-83310-60	ENSAMBLAJE DE LA LUZ	2	
115-83311-60	.BOMBILLA (6V-18W)	1	

4. Los colores de los componentes se indican como sigue en la columna de “OBSERVACIONES”.

CODIGO N°	DESCRIPCION	CANT.	OBSERVACIONES
2N4-24110-00-X5	COMP. DEL TANQUE	2	MXR
3J1-24240-10	.GRAFICO, DEL TANQUE	1	PARA MXR

- Debe tenerse en cuenta que las ilustraciones sirven como guía para la búsqueda de los números de partes y no deben usarse para el montaje. Durante el montaje, se recomienda usar el manual de taller correspondiente.

- EL asterisco (*) antes del número de referencia indica los elementos modificados después de la primera edición.

7. Números de serie

N° de Serie del motor

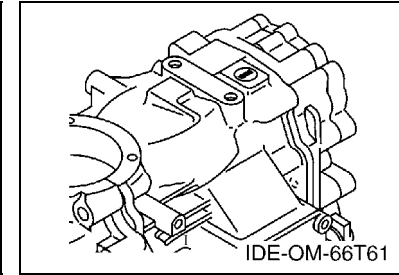
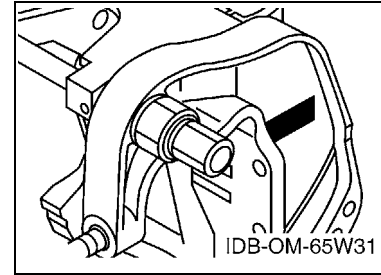

8. Números de serie del motor

Modelo	N° de serie	Modelo	N° de serie
(E)40X	66TK-1041311		

9. Códigos de color aplicables

Abreviatura	Nombre de color	Código de color
DBNM2	DARK BLUISH GRAY METALLIC 2	004D

10. Información para la columna de cantidades

Columna N°	Nombre de la columna de cantidades	Modelo aplicable
1	MH	40XMH,E40XMH
2	WH	E40XWH
3	W	40XW,E40XW
4	WT	40XWT,E40XWT

CONTENTS

SHEET1/2

TOP COWLING	A4
CYLINDER & CRANKCASE	A5
CRANKSHAFT & PISTON	A7
INTAKE	B1
CARBURETOR	B2
FUEL	B4
STARTER	B6
GENERATOR	C1
ELECTRICAL 1	C3
ELECTRICAL 2	C4
ELECTRICAL 3	C6
STARTING MOTOR	C7
BOTTOM COWLING	D1
STEERING	D3
STEERING FRICTION	D5
CONTROL	D6
REMO CON ATTACHMENT	E1
BRACKET 1	E2
BRACKET 2	E5
BRACKET 3	E7
POWER TRIM & TILT ASSY	F2
UPPER CASING	F5
LOWER CASING & DRIVE 1	F6

INDEX

NUMERICAL INDEX	G1
-----------------------	----

SHEET2/2

LOWER CASING & DRIVE 1	A4*
LOWER CASING & DRIVE 2	A6*
FUEL TANK	B1*
STEERING GUIDE	B2*
REMOTE CONTROL BOX	B3*
REMOTE CONTROL ASSY 1	B4*
REMOTE CONTROL ASSY 2	B7*
SWITCH & PANEL	C2*
OPTIONAL PARTS	C3*
REPAIR KIT 1	C4*
REPAIR KIT 2	C6*
REPAIR KIT 3	C7*

INDEX

NUMERICAL INDEX	G1*
-----------------------	-----

CONTENIDO

PAGINA1/2

SOPORTE SUPERIOR	A4
CYLINDRO & CARTER	A5
CIGUENAL & PISTON	A7
ADMISION	B1
CARBURADOR	B2
COMBUSTIBLE	B4
ARRANQUE	B6
GENERADOR	C1
EQUIPO ELECTRICO 1	C3
EQUIPO ELECTRICO 2	C4
EQUIPO ELECTRICO 3	C6
MOTOR DE ARRANQUE	C7
CUBIERTA INFERIOR	D1
DIRECCION	D3
FRICCION DE DIRECCION	D5
CONTROL	D6
CONJUNTO ADITAMENTO	E1
SOPORTE 1	E2
SOPORTE 2	E5
SOPORTE 3	E7
COMPONER Y PODER VARILLA	F2
FUNDA SUPERIOR	F5
IMPULSOR E INFERIOR 1	F6

INDICE

INDICE NUMERICO	G1
-----------------------	----

PAGINA2/2

IMPULSOR E INFERIOR 1	A4*
IMPULSOR E INFERIOR 2	A6*
DEPOSITO DE COMBUSTIBLE	B1*
DIRECCIONGUIAR	B2*
CONTROL REMOTO COMPLETO	B3*
CONTROL REMOTO COMPL 1	B4*
CONTROL REMOTO COMPL 2	B7*
PANEL DE INTERRUPTOR	C2*
PARTES OPCIONALES	C3*
ESTUCHE REPARATION 1	C4*
ESTUCHE REPARATION 2	C6*
ESTUCHE REPARATION 3	C7*

INDICE

INDICE NUMERICO	G1*
-----------------------	-----

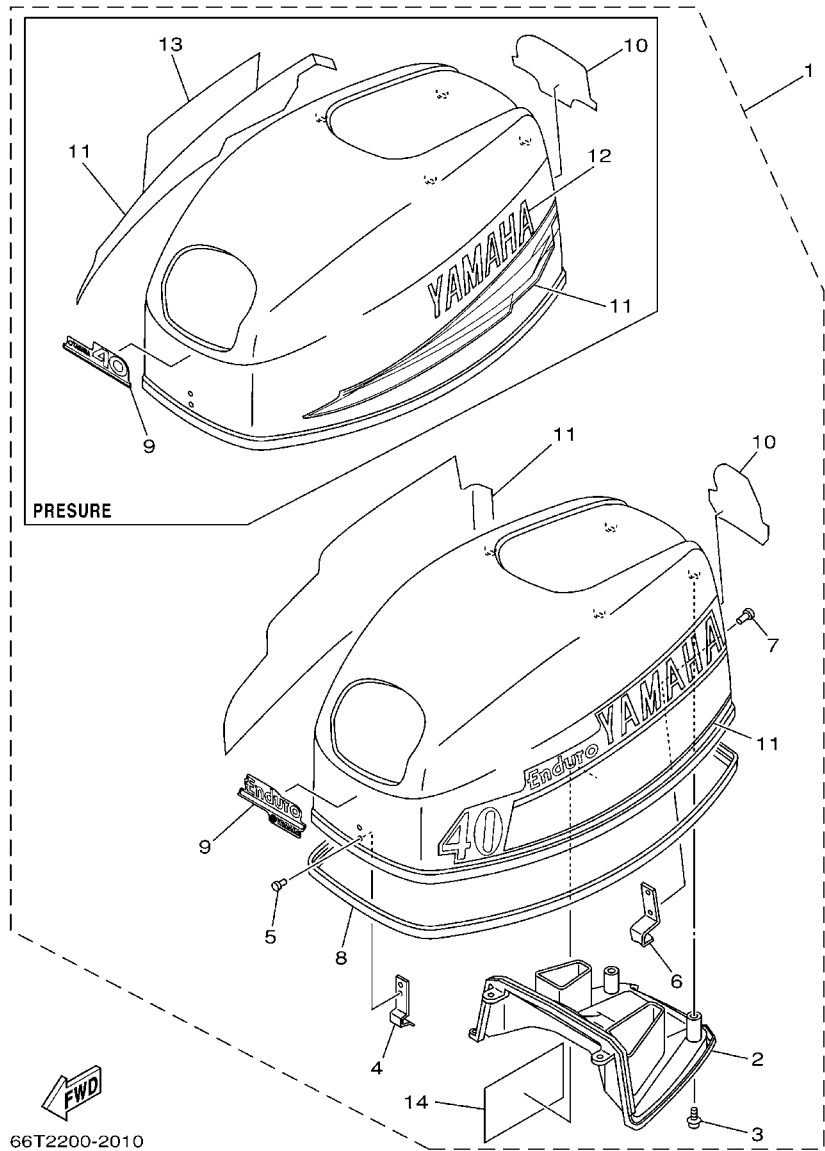

66T2200-2010

FIG. 1 TOP COWLING

SOPORTE SUPERIOR

REF. NO.	PART NO. CODIGO Nº	DESCRIPTION DESCRIPCION	MH	WH	W	WT	REMARKS OBSERVACIONES
1	66T-42610-K0-4D	TOP COWLING ASSY SOPORTE SUPERIOR COMPL.	1	1	1	1	ENDURO ENDURO
	66T-42610-20-4D	TOP COWLING ASSY SOPORTE SUPERIOR COMPL.	1	1	1	1	PLEASURE PLEASURE
2	66T-42613-01	.MOLDING, AIR DUCT .MOLDURA CONDUCTO AIRE	1	1	1	1	
3	97780-50616	.SCREW, TAPPING .TORNILLO DE CABEZA DE CONO AC	4	4	4	4	
4	6E0-42651-02	.HOOK .GANCHO	1	1	1	1	
5	90266-04M04	.RIVET .REMACHE	2	2	2	2	
6	6F5-42652-01	.HOOK .GANCHO	1	1	1	1	
7	90266-04M01	.RIVET .REMACHE	2	2	2	2	
8	66T-42615-02	.SEAL .SELLO	1	1	1	1	
9	69P-42677-H0	.GRAPHIC, FRONT .CALCAMONIA FRONTAL	1	1	1	1	ENDURO ENDURO
	63D-42677-20	.GRAPHIC, FRONT .CALCAMONIA FRONTAL	1	1	1	1	PLEASURE PLEASURE
10	6J4-42678-H0	.GRAPHIC, REAR .CALCAMONIA TRASERA	1	1	1	1	ENDURO ENDURO
	63D-42678-11	.GRAPHIC, REAR .CALCAMONIA TRASERA	1	1	1	1	PLEASURE PLEASURE
11	66T-W0070-H0	.GRAPHIC SET .JUEGO DE EMBLEMA	1	1	1	1	ENDURO ENDURO
	63D-W0070-10	.GRAPHIC SET .JUEGO DE EMBLEMA	1	1	1	1	PLEASURE PLEASURE
12	63D-42681-10	.MARK, COWLING .MARCA DE CUBIERTA	1	1	1	1	PLEASURE PLEASURE
13	63D-42682-10	.MARK, COWLING .MARCA DE CUBIERTA	1	1	1	1	PLEASURE PLEASURE
14	677-13437-0B	.MARK, CAUTION .MARKER	1	1	1	1	ENDURO ENDURO

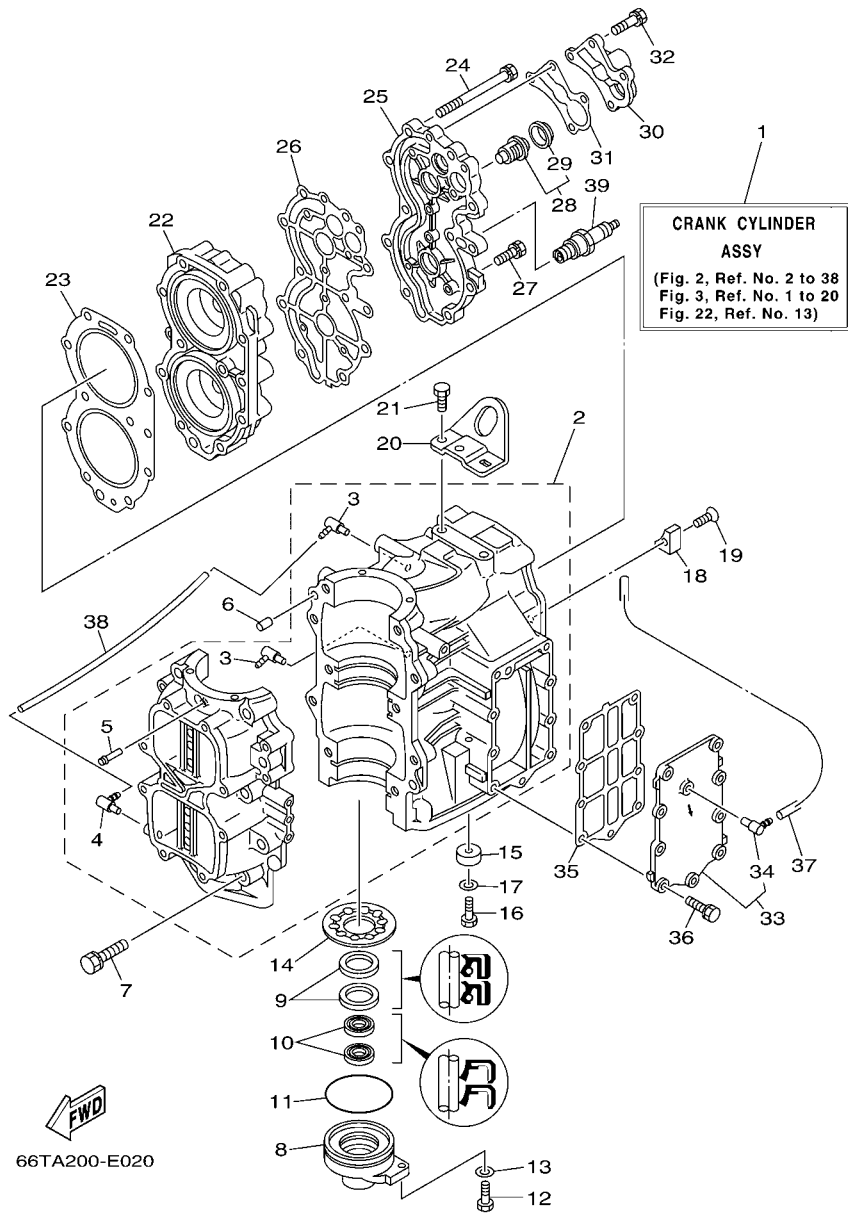

FIG. 2 CYLINDER & CRANKCASE **CYLINDRO & CARTER**

REF. NO.	PART NO. CODIGO Nº	DESCRIPTION DESCRIPCION	MH	WH	W	WT	REMARKS OBSERVACIONES
1	66T-W0090-02-1S	CRANK CYLINDER ASSY BLOQUE MOTOR COMPLETO	1	1	1	1	
2	66T-15100-02-1S	CRANKCASE ASSY CARTER COMPLETO	1	1	1	1	
3	6E5-13552-01	.NOZZLE .BOQUILLA	2	2	2	2	
4	6E5-13552-01	.NOZZLE .BOQUILLA	1	1	1	1	
5	624-14485-00	.PIPE, JOINT .TUBO DE UNION	1	1	1	1	
6	93608-12063	PIN, DOWEL PASADOR DE CLAVIJA	2	2	2	2	
7	90119-10005	BOLT, WITH WASHER TORNILLO CON ARANDELA	10	10	10	10	
8	66T-15396-01-94	HOUSING, OIL SEAL CAJA DE SELLO DE ACEITE	1	1	1	1	
9	93102-30M56	OIL SEAL SELLO ACEITE	2	2	2	2	
10	93101-16001	OIL SEAL SELLO ACEITE	2	2	2	2	
11	93210-65M50	O-RING ANILLO O	1	1	1	1	
12	97095-06020	BOLT PERNO	1	1	1	1	
13	92995-06600	WASHER ARANDELA	1	1	1	1	
14	66T-11565-00	WASHER, BEARING COVER ARANDELA CUBIERTA DE COJINETE	1	1	1	1	
15	676-45251-00	ANODE CATODE	1	1	1	1	
16	97095-06020	BOLT PERNO	1	1	1	1	
17	92995-06600	WASHER ARANDELA	1	1	1	1	
18	676-11325-00	ANODE ANODO	1	1	1	1	
19	90141-06M00	SCREW, COUNTERSUNK TORNILLO RANURADO	1	1	1	1	
20	66T-11119-00	HANGER, ENGINE SOPORTE DEL MOTOR	1	1	1	1	
21	90101-08002	BOLT TORNILLO	2	2	2	2	
22	66T-11111-01-1S	HEAD, CYLINDER 1 CULATA CILINDRO 1	1	1	1	1	
23	66T-11181-A2	GASKET, CYLINDER HEAD 1 JUNTA, DE CULATA 1	1	1	1	1	
24	90119-08MA5	BOLT, WITH WASHER TORNILLO CON ARANDELA	11	11	11	11	
25	66T-11191-00-1S	COVER, CYLINDER HEAD 1 TAPA CULATA DE CILINDRO 1	1	1	1	1	
26	66T-11193-A2	GASKET, HEAD COVER 1 EMPAQUE	1	1	1	1	
27	90119-06MA3	BOLT, WITH WASHER TORNILLO CON ARANDELA	4	4	4	4	

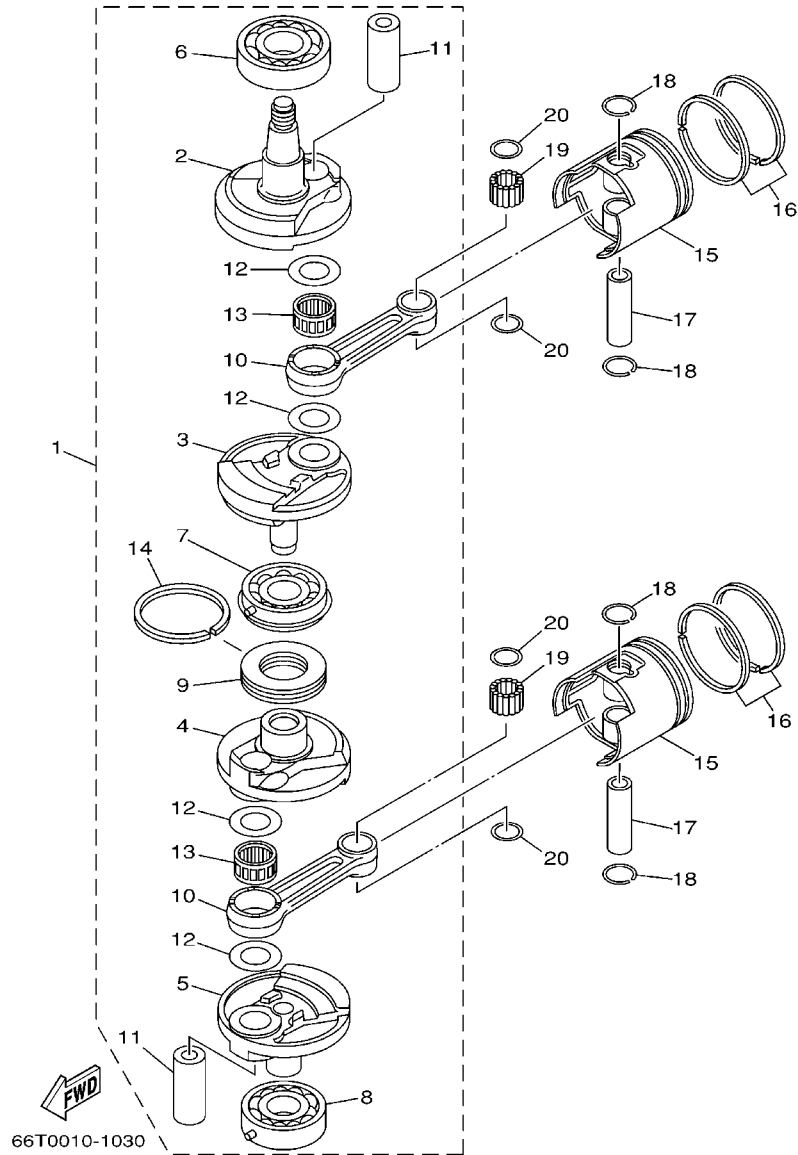

FIG. 3 CRANKSHAFT & PISTON

CIGUENAL & PISTON

REF. NO.	PART NO. CODIGO Nº	DESCRIPTION DESCRIPCION	MH	WH	W	WT	REMARKS OBSERVACIONES
1	66T-11400-01	CRANKSHAFT ASSY CIGUENAL COMPLETO	1	1	1	1	
2	66T-11412-00	.CRANK 1 .MANIVELA 1	1	1	1	1	
3	66T-11422-00	.CRANK 2 .MANIVELA 2	1	1	1	1	
4	66T-11432-00	.CRANK 3 .MANIVELA 3	1	1	1	1	
5	66T-11442-00	.CRANK 4 .MANIVELA 4	1	1	1	1	
6	93306-307U0	.BEARING .COJINETE	1	1	1	1	
7	93332-000UE	.BEARING .COJINETE	1	1	1	1	
8	93306-306V5	.BEARING .COJINETE	1	1	1	1	
9	6F5-11515-00	.SEAL, LABYRINTH 1 .SELLO LABERINTO 1	1	1	1	1	
10	6F5-11651-00	.ROD, CONNECTING .BIELA	2	2	2	2	
11	66T-11681-00	.PIN, CRANK 1 .PASADOR MANIVELA 1	2	2	2	2	
12	90209-27012	.WASHER .ARANDELA DE SEPARACION	4	4	4	4	
13	93310-727U0	.BEARING .COJINETE DE RODILLOS	2	2	2	2	
14	93440-68M03	.CIRCLIP .SEGURO	1	1	1	1	
15	66T-11631-01-93	PISTON (STD) PISTON (NORMA)	2	2	2	2	
	66T-11635-01	PISTON (0.25MM O/S)	2	2	2	2	AP
	66T-11636-01	PISTON (0.25MM O/S) PISTON (0.50MM O/S) PISTON (0.50MM O/S)	2	2	2	2	AP AP AP
16	66T-11603-00	PISTON RING SET (STD) JUEGO DE ANILLOS (NORMA)	2	2	2	2	
	66T-11604-00	PISTON RING SET (0.25MM O/S) JUEGO DE ANILLOS (0.25MM O/S)	2	2	2	2	AP AP
	66T-11605-00	PISTON RING SET (0.50MM O/S) JUEGO DE ANILLOS (0.50MM O/S)	2	2	2	2	AP AP
17	6F5-11633-00	PIN, PISTON PASADOR, PISTON	2	2	2	2	
18	663-11634-00	CLIP, PISTON PIN PRESILLA, BULON DE PISTON	4	4	4	4	
19	93603-21111	PIN, DOWEL PASADOR DE CLAVIJA	56	56	56	56	
20	90201-20417	WASHER, PLATE ARANDELA PLANA	4	4	4	4	

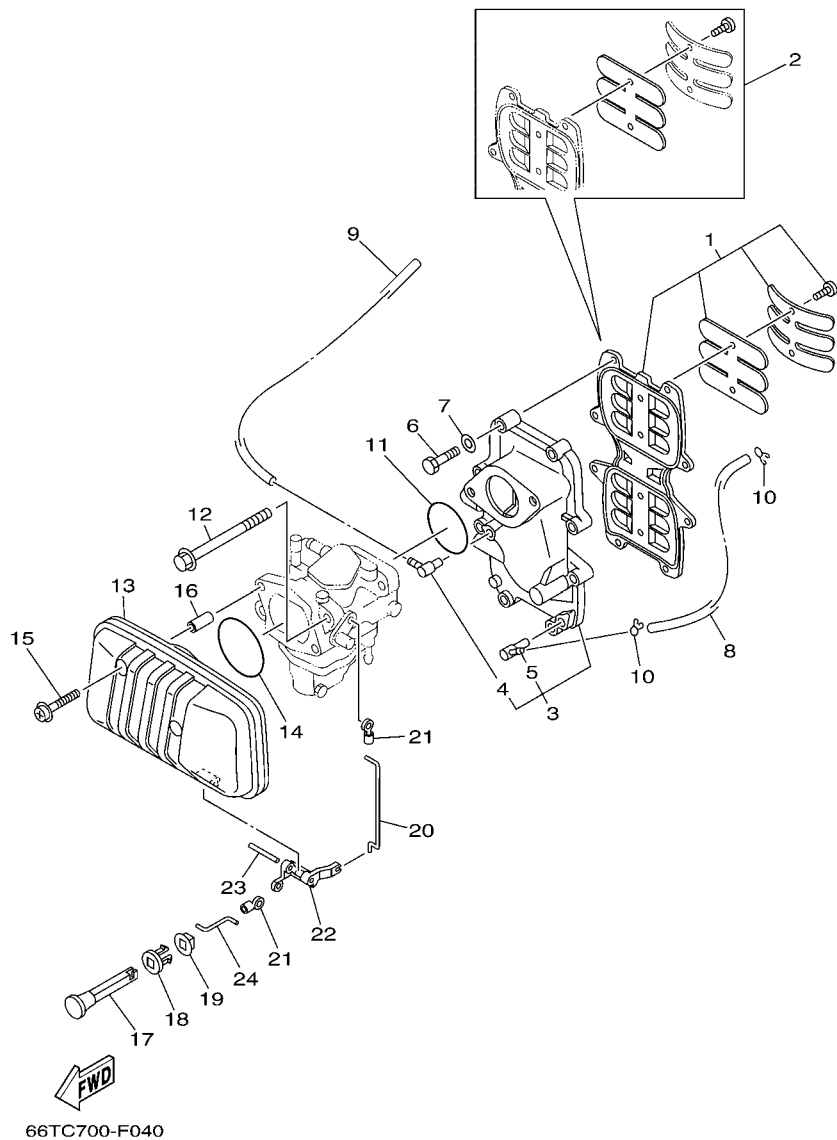

FIG. 4 INTAKE

ADMISION

REF. NO.	PART NO. CODIGO Nº	DESCRIPTION DESCRIPCION	MH	WH	W	WT	REMARKS OBSERVACIONES
1	66T-13610-00	REED VALVE ASSY VALVULA DE LAMINAS COMPLETA	1	1	1	1	
2	66T-W0004-00	.REED SET .JUEGO DE VALVULAS DE LENGUETA	1	1	1	1	
3	66T-13641-02-1S	MANIFOLD 1 MULTIPLE 1	1	1	1	1	
4	6E5-13552-01	.NOZZLE .BOQUILLA	1	1	1	1	
5	650-11372-01	.NIPPLE, HOSE .NIPLE DE MANGUERA	1	1	1	1	
6	97013-06035	BOLT PERNO	8	8	8	8	
7	92903-06600	WASHER, PLATE RONDANA SENCILLA	8	8	8	8	
8	90445-07M24	HOSE (L240) TUBO (L240)	1	1	1	1	
9	90445-07MA4	HOSE (L280) TUBO (L280)	1	1	1	1	
10	90467-06016	CLIP PRESILLA	2	2	2	2	
11	93210-46M16	O-RING ANILLO O	1	1	1	1	
12	90119-08M03	BOLT, WITH WASHER TORNILLO CON ARANDELA	2	2	2	2	
13	66T-14440-00	SILENCER ASSY, INTAKE SILENCIADOR COMPL DE ADMISION	1	1	1	1	
14	93210-54M54	O-RING ANILLO O	1	1	1	1	
15	90159-06034	SCREW, WITH WASHER TORNILLO CON VALONA	2	2	2	2	
16	90387-06M80	COLLAR ESPACIADOR	2	2	2	2	
17	6H4-41271-01	KNOB, CHOKE PERILLA AHOGADOR	1	1	1	1	
18	689-41273-00	GROMMET TAPON PROTECTOR	1	1	1	1	
19	6J8-41274-00	GROMMET 2 TAPON 2	1	1	1	1	
20	66T-41256-00	ROD, CHOKE 1 VARILLA DE AHOGADOR	1	1	1	1	
21	661-41262-02	JOINT, CHOKE LEVER CONECTOR DE AHOGADOR	2	2	2	2	
22	66T-41252-00	LEVER, CHOKE 1 PALANCA AHOGADOR 1	1	1	1	1	
23	91690-40032	PIN, SPRING PASADOR DE RESORTE	1	1	1	1	
24	66T-41257-00	ROD, CHOKE 2 VARILLA DE AHOGADOR	1	1	1	1	

FIG. 5 CARBURETOR

CARBURADOR

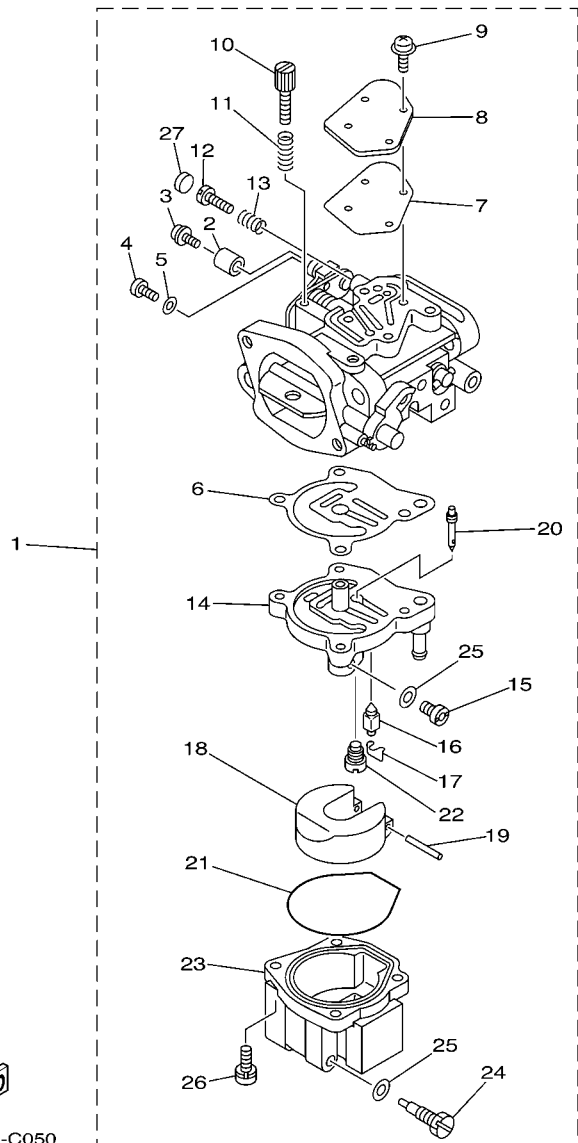

66T6200-C050

REF. NO.	PART NO. CODIGO Nº	DESCRIPTION DESCRIPCION	MH	WH	W	WT	REMARKS OBSERVACIONES
1	66T-14301-02	CARBURETOR ASSY 1 CARBURADOR COMPLETO 1	1	1			
	66T-14301-12	CARBURETOR ASSY 1 CARBURADOR COMPLETO 1			1	1	
	66T-14301-40	CARBURETOR ASSY 1 CARBURADOR COMPLETO 1	1	1			FOR CAR(EPA) FOR CAR(EPA)
	66T-14301-50	CARBURETOR ASSY 1 CARBURADOR COMPLETO 1				1	FOR CAR(EPA) FOR CAR(EPA)
2	66T-14578-00	.COLLAR .COLLAR	1	1	1	1	
3	66T-14584-00	.STOPPER .RETENER	1	1	1	1	
4	6J8-14592-01	.SCREW .TORNILLO	1	1	1	1	
5	92990-05600	.WASHER, PLATE .ARANDELA PLANA	1	1	1	1	
6	66T-14384-01	.GASKET, FLOAT CHAMBER .EMPAQUE DE CAMARA DE BOIA	1	1	1	1	
7	66T-14536-00	.GASKET .EMPAQUE	1	1	1	1	
8	66T-14527-00	.PLATE .PLACA	1	1	1	1	
9	97980-04112	.SCREW, WITH WASHER .TORNILLO, CON ARANDELA	4	4	4	4	
10	66T-14523-00	.SCREW, STOP .TORNILLO DE TOPE	1	1	1	1	
11	6J8-14334-00	.SPRING, THROTTLE .RESORTE DE AJUSTADOR DE AIRE	1	1	1	1	
12	6E5-14323-03	.SCREW, AIR ADJUSTING .TORNILLO DE AJUSTE DE AIRE	1	1	1	1	
13	6E5-14223-00	.SPRING, AIR ADJUSTING .RESORTE, AJUSTE DE AIRE	1	1	1	1	
14	66T-14945-02	.SPACER ASSY (#38) .BRIDA DE ESPACIADOR 1 (#38)	1	1	1	1	
15	61A-1492E-85	.JET, MAIN (#170) .INJECTOR, PRINCIPAL (#170)	1	1	1	1	
16	6E5-14546-00	.VALVE, NEEDLE .VALVULA DE AGUJA	1	1	1	1	
17	6E5-14159-00	.CLIP .PRESILLA	1	1	1	1	
18	6E5-14385-02	.FLOAT .BOIA	1	1	1	1	
19	6E5-14386-02	.PIN, FLOAT .PASADOR DE BOIA	1	1	1	1	
20	66T-1492F-35	.JET, AIR SLOW (#70) .ESPREA (#70)	1	1	1	1	
21	66T-14984-00	.GASKET, FLOAT CHAMBER .EMPAQUE CAMARA DE BOIA	1	1	1	1	
22	66T-14992-00	.PLUG .TAPON	1	1	1	1	
23	66T-14981-00	.BODY, FLOAT CHAMBER .CUERPO CAMARA DE BOIA	1	1	1	1	
24	66T-14991-00	.PLUG, DRAIN .TAPON, DREN	1	1	1	1	

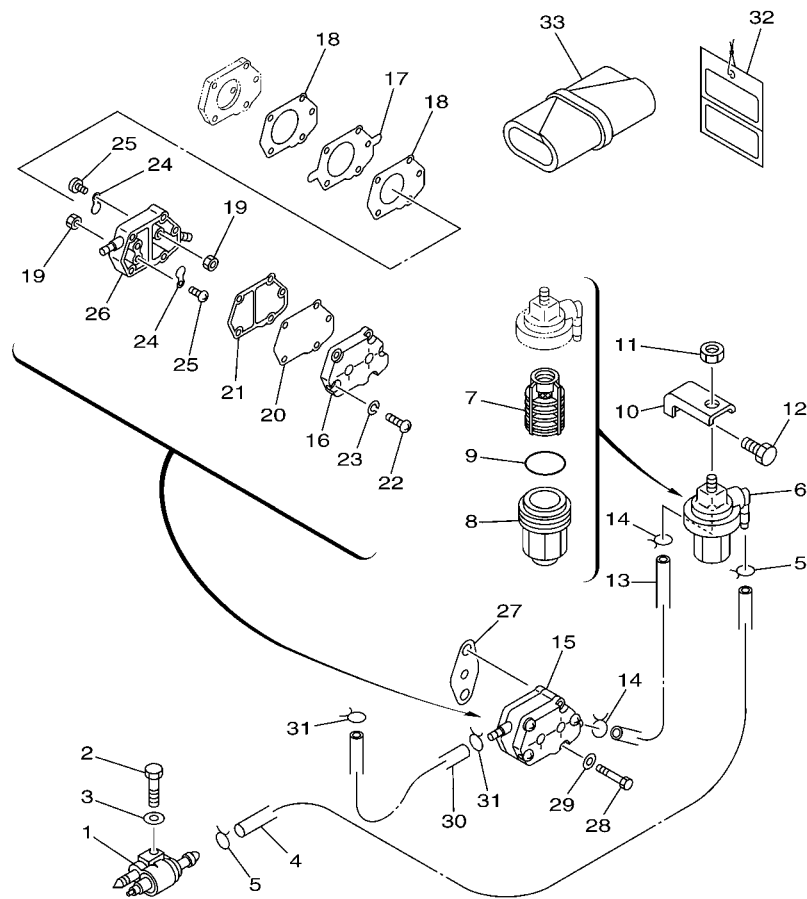

66T6700-C060

FIG. 6 FUEL

COMBUSTIBLE

REF. NO.	PART NO. CODIGO Nº	DESCRIPTION DESCRIPCION	MH	WH	W	WT	REMARKS OBSERVACIONES
1	6G1-24304-02	FUEL PIPE JOINT COMP. 1 CONECTOR MANGUERA COMBUST.1	1	1	1	1	
2	97095-06030	BOLT PERNO	1	1	1	1	
3	92995-06600	WASHER ARANDELA	1	1	1	1	
4	90445-09M08	HOSE (L550) TUBO (L550)	1	1	1	1	
5	90467-08004	CLIP PRESILLA	2	2	2	2	
6	61N-24560-00	FILTER ASSY FILTRO COMPLETO	1	1	1	1	
7	61N-24563-00	.ELEMENT, FILTER .ELEMENTO DEL FILTRO	1	1	1	1	
8	61N-24521-00	.CUP, FILTER .COPA DE FILTRO	1	1	1	1	
9	93210-32738	.O-RING .ANILLO O	1	1	1	1	
10	648-24566-02	BRACKET, FILTER SOPORTE DEL FILTRO	1	1	1	1	
11	95380-08600	NUT TUERCA	1	1	1	1	
12	97013-06014	BOLT PERNO	1	1	1	1	
13	90445-09086	HOSE (L170) TUBO (L170)	1	1	1	1	
14	90467-08004	CLIP PRESILLA	2	2	2	2	
15	692-24410-00	FUEL PUMP ASSY BOMBA DE COMBUSTIBLE COMPLETA	1	1	1	1	
16	6A0-24413-00	.BODY 2 .CUERPO 2	1	1	1	1	
17	692-24411-00	.DIAPHRAGM .DIAFRAGMA	1	1	1	1	
18	648-24434-01	.GASKET, BODY .EMPAQUE	2	2	2	2	
19	95380-03600	.NUT .TUERCA	2	2	2	2	
20	663-24411-00	.DIAPHRAGM .DIAFRAGMA	1	1	1	1	
21	648-24435-02	.GASKET, BODY 2 .EMPAQUE	1	1	1	1	
22	98503-05028	.SCREW, PAN HEAD .TORNILLO DE CABEZA DE CONO AC	3	3	3	3	
23	92990-05100	.WASHER, SPRING .ARANDELA PLANA	3	3	3	3	
24	6A0-24421-01	.VALVE, CHECK .VALVULA DE RETENCION	2	2	2	2	
25	6A0-14325-00	.SCREW, PAN HEAD .TORNILLO CABEZA REDONDA	2	2	2	2	
26	6A0-24412-02	.BODY 1 .CUERPO 1	1	1	1	1	
27	650-24431-A0	GASKET, FUEL PUMP 1 EMPAQUE BOMBA COMBUST 1	1	1	1	1	

B4

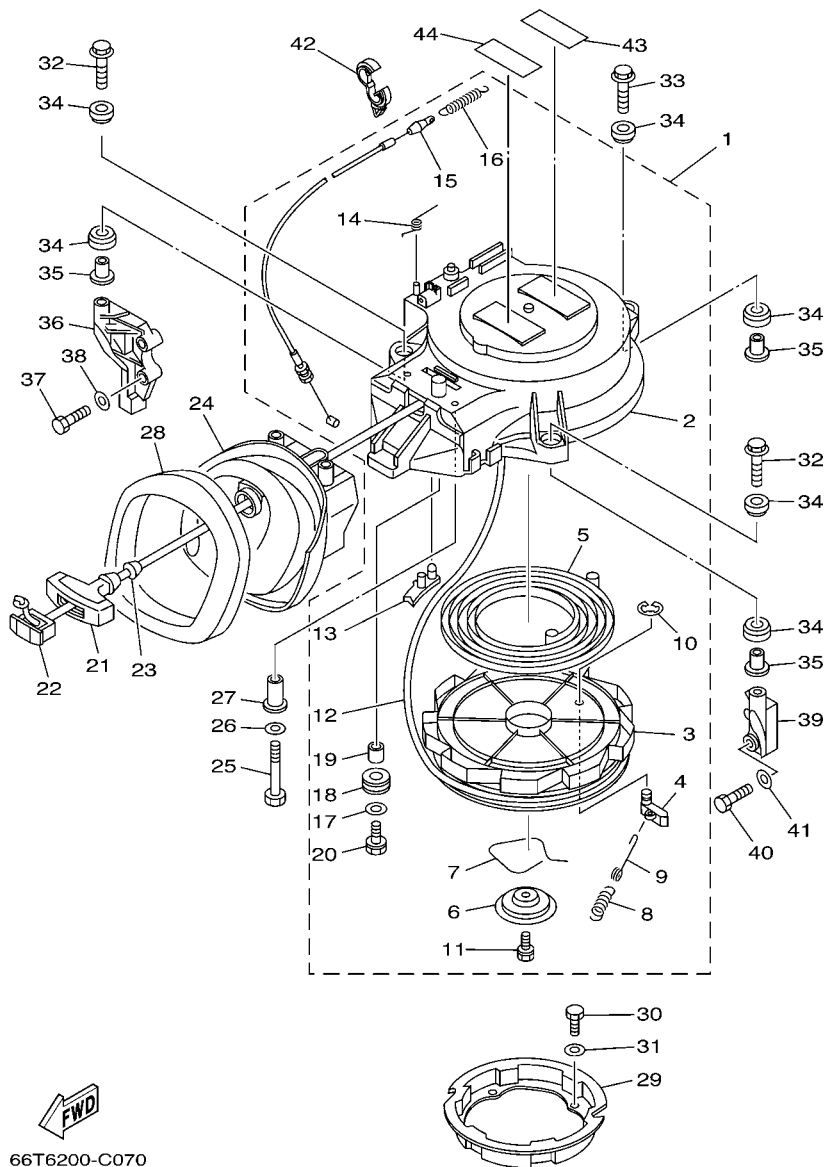

66T6200-C070

*1: CUT FROM 50M ROLLS, PART NO. 90890-44374, CUTTING LENGTH 1.8M
 *1: CORTE DE UN RODILLO DE 50M , PARTS NUMERO 90890-44374, LARGO DEL CORTE 1.8M

FIG. 7 STARTER

ARRANQUE

REF. NO.	PART NO. CODIGO Nº	DESCRIPTION DESCRIPCION	MH	WH	W	WT	REMARKS OBSERVACIONES
1	66T-15710-00	STARTER ASSY .ARRANQUE COMPLETO	1	1	1	1	
2	66T-15711-00	.CASE, STARTER .CAJA DE ARRANQUE	1	1	1	1	
3	66T-15714-00	.DRUM, SHEAVE .TAMBOR ROLDANA	1	1	1	1	
4	63V-15741-00	.PAWL, DRIVE .TRINQUETE DE TRACCION	1	1	1	1	
5	66T-15713-00	.SPRING, STARTER .RESORTE DE ARRANQUE	1	1	1	1	
6	66T-15716-00	.PLATE, DRIVE .PLACA DE TRACCION	1	1	1	1	
7	66T-15705-00	.SPRING, DRIVE PAWL .RESORTE	1	1	1	1	
8	66T-15767-00	.SPRING .RESORTE	1	1	1	1	
9	66T-15784-00	.SPRING, RETURN .RESORTE DE RETORNO	1	1	1	1	
10	63V-15744-00	.CIRCLIP .SEGURO	1	1	1	1	
11	63V-15768-00	.BOLT .TORNILLO	1	1	1	1	
12	*	.WIRE, STARTER (L:1800MM) .CUERDA DE ARRANQUE (L:1800MM)	1	1	1	1	*1 *1
13	66T-15794-00	.STOPPER .TOPE	1	1	1	1	
14	66T-15734-00	.SPRING, RETURN .RESORTE DE RETORNO	1	1	1	1	
15	66T-15770-00	.CABLE COMP., STARTER STOP .CABLECOMPL DE SEGURO ARRANQUE	1	1	1	1	
16	66T-15731-00	.SPRING, RETURN .RESORTE DE RETORNO	1	1	1	1	
17	6F5-15791-00	.WASHER, LOCK .EMBLEMA	1	1	1	1	
18	6F5-15752-00	.ROLLER, WIRE .RODILLO DE CUERDA	1	1	1	1	
19	6F5-15753-00	.BUSH .BUJE	1	1	1	1	
20	6F5-15768-00	.BOLT .TORNILLO	1	1	1	1	
21	689-15755-01	HANDLE, STARTER MANIJA DE ARRANQUE	1	1	1	1	
22	6F5-15779-02	COVER CUBIERTA	1	1	1	1	
23	697-15789-00	DAMPER AMORTIGUADOR	1	1	1	1	
24	66T-15758-01	GUIDE, ROPE GUIA DE CUERDA	1	1	1	1	
25	97095-06035	BOLT PERNO	2	2	2	2	
26	92995-06600	WASHER ARANDELA	2	2	2	2	
27	90387-06M66	COLLAR ESPACIADOR	2	2	2	2	

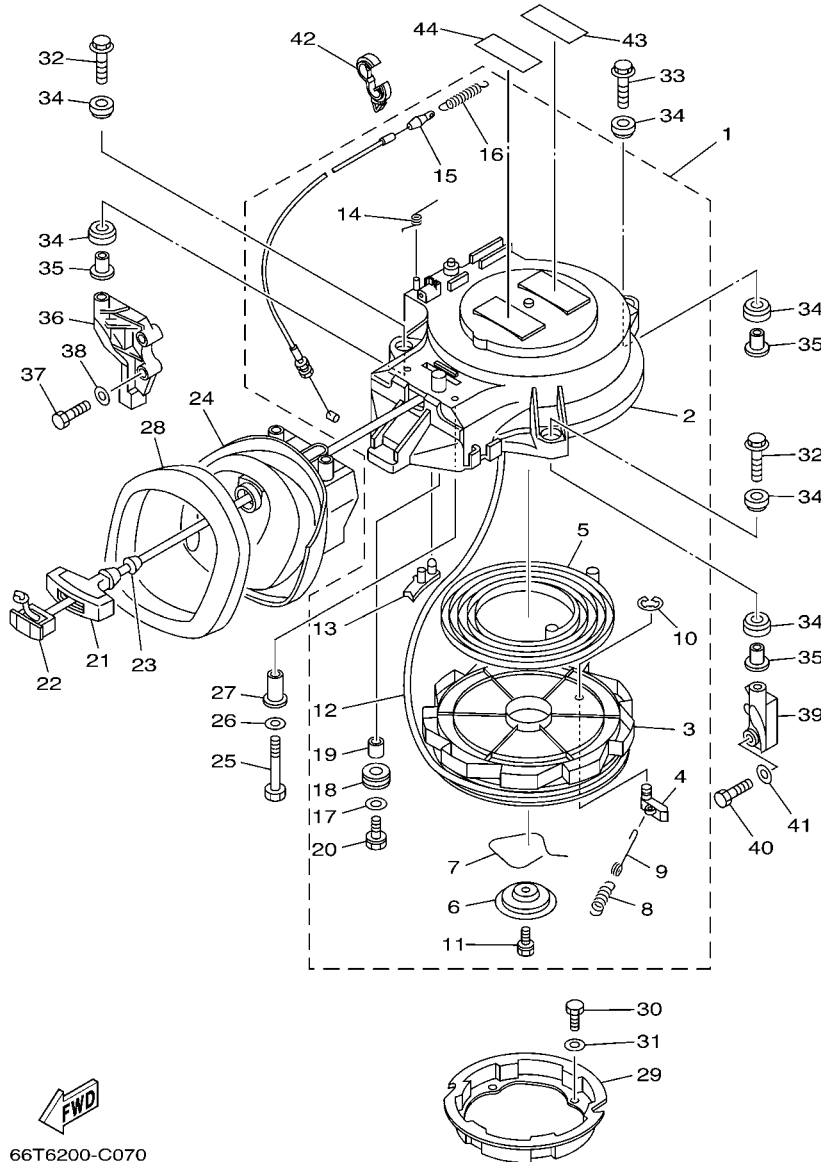

66T6200-C070

*1: CUT FROM 50M ROLLS, PART NO. 90890-44374, CUTTING LENGTH 1.8M

*1: CORTE DE UN RODILLO DE 50M , PARTS NUMERO 90890-44374, LARGO DEL CORTE 1.8M

FIG. 7 STARTER

ARRANQUE

REF. NO.	PART NO. CODIGO Nº	DESCRIPTION DESCRIPCION	MH	WH	W	WT	REMARKS OBSERVACIONES
28	66T-15762-01	SEAL, RUBBER 2 SELLO DE GOMA 2	1	1	1	1	
29	66T-15723-00	PULLEY, STARTER POLEA DE ARRANQUE	1	1	1	1	
30	97095-06010	BOLT PERNO	4	4	4	4	
31	92995-06600	WASHER ARANDELA	4	4	4	4	
32	90119-08M10	BOLT, WITH WASHER TORNILLO CON ARANDELA	2	2	2	2	
33	90119-08M51	BOLT, WITH WASHER TORNILLO CON ARANDELA	1	1	1	1	
34	90385-12M04	BUSH BUJE	6	6	6	6	
35	90387-08M05	COLLAR ESPACIADOR	3	3	3	3	
36	66T-15771-00-94	STAY 1 SOPORTE 1	1	1	1	1	
37	97013-06030	BOLT PERNO	2	2	2	2	
38	92903-06600	WASHER, PLATE RONDANA SENCILLA	2	2	2	2	
39	66T-15772-00-94	STAY 2 SOPORTE 2	1	1	1	1	
40	97013-06030	BOLT PERNO	2	2	2	2	
41	92903-06600	WASHER, PLATE RONDANA SENCILLA	2	2	2	2	
42	90464-13249	CLAMP BRIDA	1	1	1	1	
43	6A1-83625-41	MARK 5 MARCA 5	1	1	1	1	
44	61T-83625-80	MARK 5 MARCA 5	1	1	1	1	FOR RUS FOR RUS

FIG. 8 GENERATOR

GENERADOR

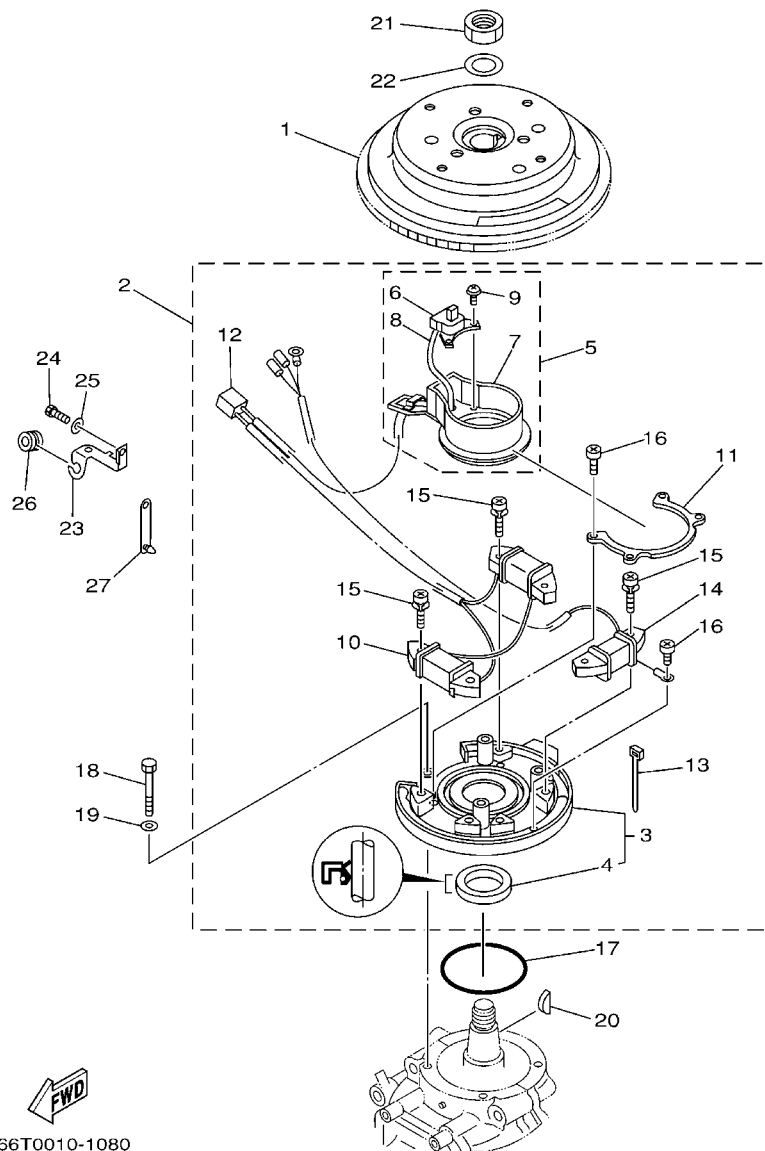

66T0010-1080

REF. NO.	PART NO. CODIGO Nº	DESCRIPTION DESCRIPCION	MH	WH	W	WT	REMARKS OBSERVACIONES
1	66T-85550-00	ROTOR ASSY ROTOR COMPLETO		1	1	1	
	66T-85550-10	ROTOR ASSY ROTOR COMPLETO	1				
2	66T-85560-01	BASE ASSY CONJUNTO BASE	1	1	1	1	
	66T-85560-11	BASE ASSY CONJUNTO BASE	1				
3	66T-85561-00	.BASE, MAGNETO .BASE DE MAGNETO	1	1	1	1	
4	93102-35008	..OIL SEAL ..SELLO ACEITE	1	1	1	1	
5	66T-85580-00	.PULSER COIL ASSY .BOBINA DE PULSACION COMPLETA	1	1	1	1	
6	66T-85596-00	..COIL, PULSER 1 ..BOBINA DE PULSACION 1	1	1	1	1	
7	66T-85582-00	..ATTACHMENT, PULSER ..IMPLEMENTO DE PULSACION	1	1	1	1	
8	66T-85515-00	..LEAD WIRE ASSY ..CABLE CONDUCTOR COMPLETO	1	1	1	1	
9	97902-04108	..SCREW, WITH WASHER ..TORNILLO, CON ARANDELA	2	2	2	2	
10	66T-85520-00	.COIL, CHARGE .BOBINA DE CARGA	1	1	1	1	
11	66T-41611-00	.RETAINER, MAGNETO BASE .RETENEDOR BASE MAGNETO	1	1	1	1	
12	9E471-04305	.CONNECTOR .CONECTOR	1	1	1	1	
13	66T-81328-00	.CLAMP .GRAMPA	1	1	1	1	
14	66T-85533-00	.COIL, LIGHTING .BOBINA DE LUZ	1	1	1	1	FOR 66T-85560-01 FOR 66T-85560-01
15	97902-06125	.SCREW, WITH WASHER .TORNILLO, CON ARANDELA	6	6	6	6	FOR 66T-85560-01 FOR 66T-85560-01
	97902-06125	.SCREW, WITH WASHER .TORNILLO, CON ARANDELA	4				FOR 66T-85560-11 FOR 66T-85560-11
16	97802-04006	.SCREW, PAN HEAD .TORNILLO	5	5	5	5	FOR 66T-85560-01 FOR 66T-85560-01
	97802-04006	.SCREW, PAN HEAD .TORNILLO	4				FOR 66T-85560-11 FOR 66T-85560-11
17	93210-75M51	O-RING ANILLO O	1	1	1	1	
18	97095-06040	BOLT PERNO	4	4	4	4	
19	92995-06600	WASHER ARANDELA	4	4	4	4	
20	90280-05015	KEY, WOODRUFF CUNA WOODRUFF	1	1	1	1	
21	90170-20137	NUT TUERCA	1	1	1	1	
22	90201-21M18	WASHER, PLATE ARANDELA PLANA	1	1	1	1	
23	90465-15M74	CLAMP BRIDA	1	1	1	1	

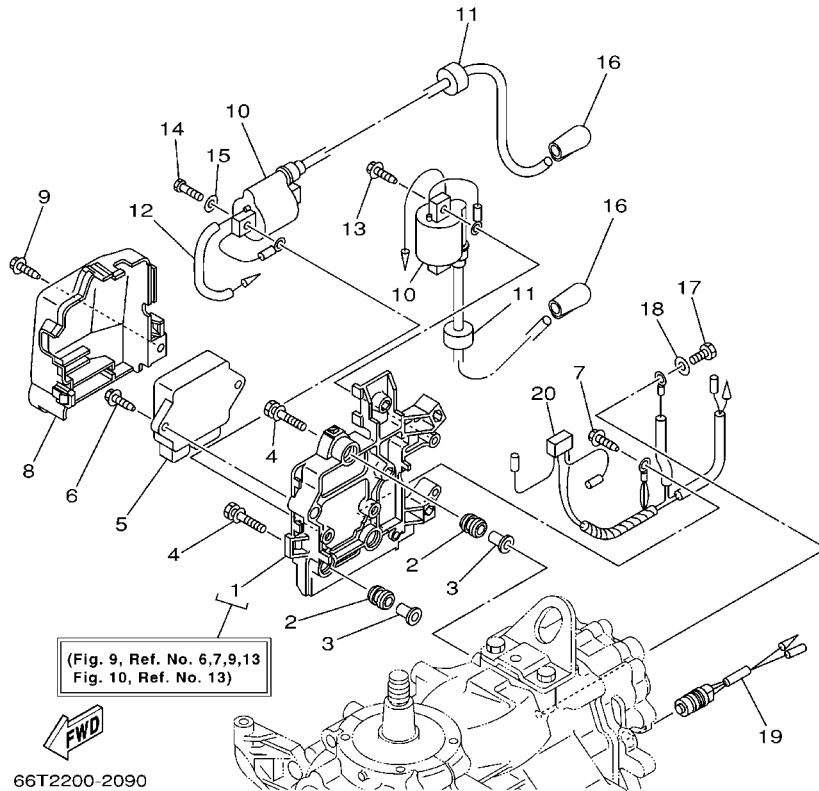
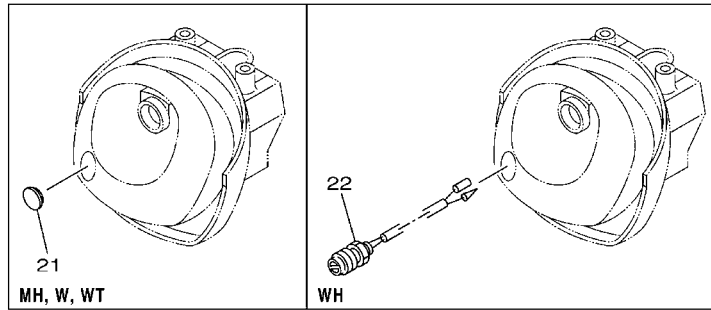

FIG. 9 ELECTRICAL 1

EQUIPO ELECTRICO 1

REF. NO.	PART NO. CODIGO N°	DESCRIPTION DESCRIPCION	MH	WH	W	WT	REMARKS OBSERVACIONES
1	66T-8554B-01-94	BRACKET SOPORTE	1	1	1	1	
2	6A0-82317-00	DAMPER, IGNITION COIL AMORTIGUADOR BOBINA ENCENDIDO	3	3	3	3	
3	90387-06119	COLLAR ESPACIADOR	3	3	3	3	
4	90119-06M65	BOLT, WITH WASHER TORNILLO CON ARANDELA	3	3	3	3	
5	66T-85540-00	C.D.I. UNIT ASSY UNIDAD C.D.I. COMPLETA	1	1	1	1	
6	90109-06M81	BOLT PERNO	2	2	2	2	
7	90109-06M80	BOLT PERNO	1	1	1	1	
8	66T-81916-01	COVER, TERMINAL CUBIERTA DE TERMINAL	1	1	1	1	
9	90109-06M81	BOLT PERNO	1	1	1	1	
10	66T-85570-00	IGNITION COIL ASSY BOBINA DE IGNICION COMPLETO	2	2	2	2	
11	90480-25161	GROMMET TAPON	2	2	2	2	
12	90446-03MA3	HOSE TUBO RESEIRADERO	1	1	1	1	
13	90109-06M81	BOLT PERNO	2	2	2	2	
14	97095-06025	BOLT PERNO	2	2	2	2	
15	92995-06600	WASHER ARANDELA	2	2	2	2	
16	66T-82370-00	PLUG CAP ASSY TAPON DE BUJIA COMPLT	2	2	2	2	
	6E3-82370-21	PLUG CAP ASSY TAPON DE BUJIA COMPLT	2	2			FOR CAR(CE) FOR CAR(CE)
17	97095-06012	BOLT PERNO	1	1	1	1	
18	92995-06600	WASHER ARANDELA	1	1	1	1	
19	688-82560-10	THERMO SWITCH ASSY INTER. DE TERMO	1	1	1	1	
20	66T-82519-00	WIRE, EARTH LEAD CABLE CONDUCTOR A TIERRA	1	1			
21	6G1-42725-00	GROMMET TAPON	1		1	1	
22	689-81870-00	STARTING SWITCH ASSY INTERRUPTOR DE ARRANQUE COMPL.		1			

FIG. 10 ELECTRICAL 2

EQUIPO ELECTRICO 2

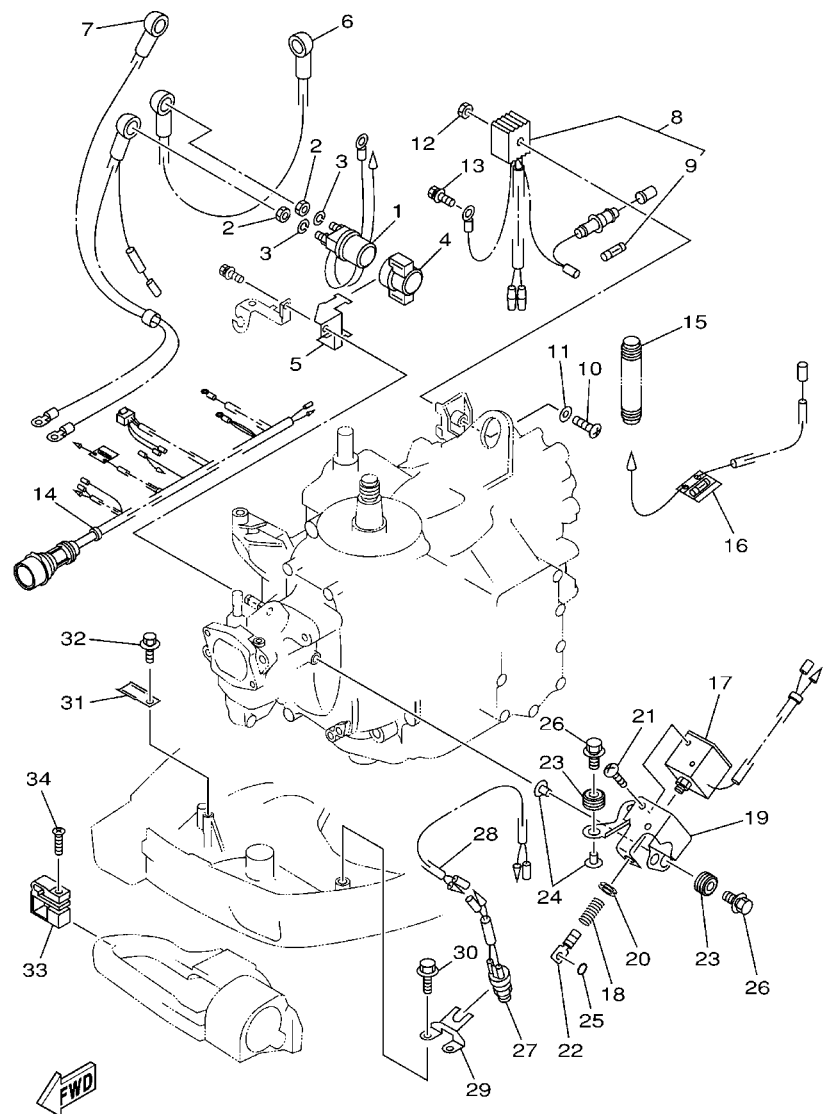

66T0200-1100

REF. NO.	PART NO. CODIGO Nº	DESCRIPTION DESCRIPCION	MH	WH	W	WT	REMARKS OBSERVACIONES
1	6G1-8194A-10	RELAY RELE		1	1	1	
2	90170-06M30	NUT TUERCA		2	2	2	
3	90204-06M00	WASHER, SPRING ARANDELA DE RESORTE		2	2	2	
4	6G1-81952-00	HOLDER, RELAY SOSTEN DE RELE		1	1	1	
5	6L2-81945-00	PLATE, SWITCH FITTING PLACA ACCESORIA DE INTERRUPT.		1	1		
6	6E5-82117-01	WIRE, LEAD CABLE CONDUCTOR		1	1	1	
7	66T-82105-00	WIRE HARNESS ARNES DE CABLES		1	1	1	
8	6G1-81970-61	RECTIFIER ASSY RECTIFICADOR COMPLETO		1	1	1	
9	6G1-82151-00	.FUSE (10A) .FUSIBLE (10A)		1	1	1	
10	97880-05030	SCREW, PAN HEAD TORNILLO DE CABEZA CON PLANA		1	1	1	
11	92990-05600	WASHER, PLATE ARANDELA PLANA		1	1	1	
12	95380-05600	NUT TUERCA		1	1	1	
13	90109-06M80	BOLT PERNO		1	1	1	
14	66T-82590-00	WIRE HARNESS ASSY CONJUNTO DE CABLES			1		
15	66T-83557-00	TUBE (I.DIA:13MM) ENCHUFE DE ACEITE (I.DIA:13MM)		1	1		
16	66T-82115-00	WIRE, PLUS LEAD CABLE CONDUCTOR POSITIVO		1			
17	6J4-86111-00	COIL, SOLENOID CONJUNTO BOBINA SOLENOIDE			1	1	
18	6J4-86116-00	WIRE, PULL ALAMBRE-JALADOR			1	1	
19	66T-86112-00	STAY, SOLENOID SOPORTE SOLENOIDE			1	1	
20	90480-10155	GROMMET TAPON			1	1	
21	97880-05008	SCREW, PAN HEAD TORNILLO DE CABEZA CON PLANA		4	4		
22	682-86117-00	HOOK, WIRE PULL GANCHO JALADOR DE ALAMBRE			1	1	
23	90480-10M23	GROMMET TAPON			3	3	
24	90387-06M60	COLLAR ESPACIADOR			3	3	
25	93210-03261	O-RING ANILLO O			1	1	
26	90119-06M88	BOLT, WITH WASHER TORNILLO CON ARANDELA			3	3	
							W-FOR RUS W-FOR RUS

FIG. 11 ELECTRICAL 3

EQUIPO ELECTRICO 3

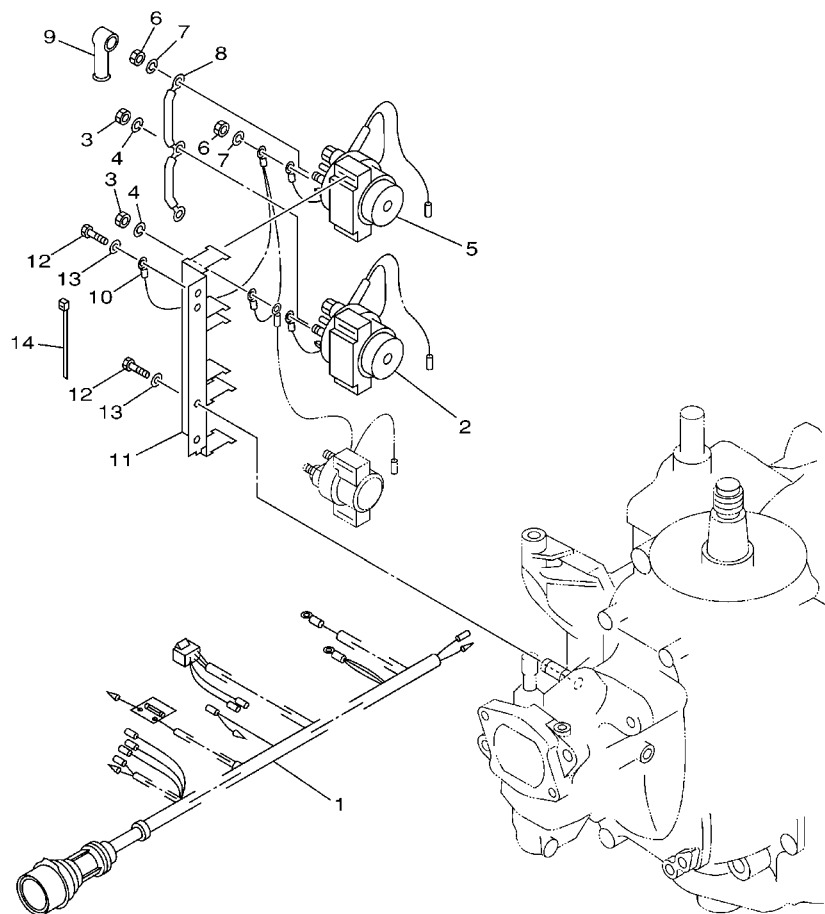

66T0010-1110

REF. NO.	PART NO. CODIGO Nº	DESCRIPTION DESCRIPCION	MH	WH	W	WT	REMARKS OBSERVACIONES
1	66T-82590-20	WIRE HARNESS ASSY (10P) CONJUNTO DE CABLES (10P)				1	
2	6E5-8195B-01	RELAY ASSY RELE COMPLETO				1	
3	90170-06M30	NUT TUERCA				3	
4	90204-06M00	WASHER, SPRING ARANDELA DE RESORTE				3	
5	6E5-8195C-01	RELAY ASSY RELE COMPLETO				1	
6	90170-06M30	NUT TUERCA				3	
7	90204-06M00	WASHER, SPRING ARANDELA DE RESORTE				3	
8	66T-87149-00	CONNECTOR CONECTOR				1	
9	6G5-82119-00	COVER, LEAD WIRE CUBIERTA DE CABLE CONDUCTOR				4	
10	6E5-82116-00	WIRE, MINUS LEAD CABLE CONDUCTOR NEGATIVO				1	
11	66T-81948-00	BRACKET SOPORTE				1	
12	97095-06016	BOLT PERNO				2	
13	92995-06600	WASHER ARANDELA				2	
14	90465-11M10	CLAMP BRIDA				1	

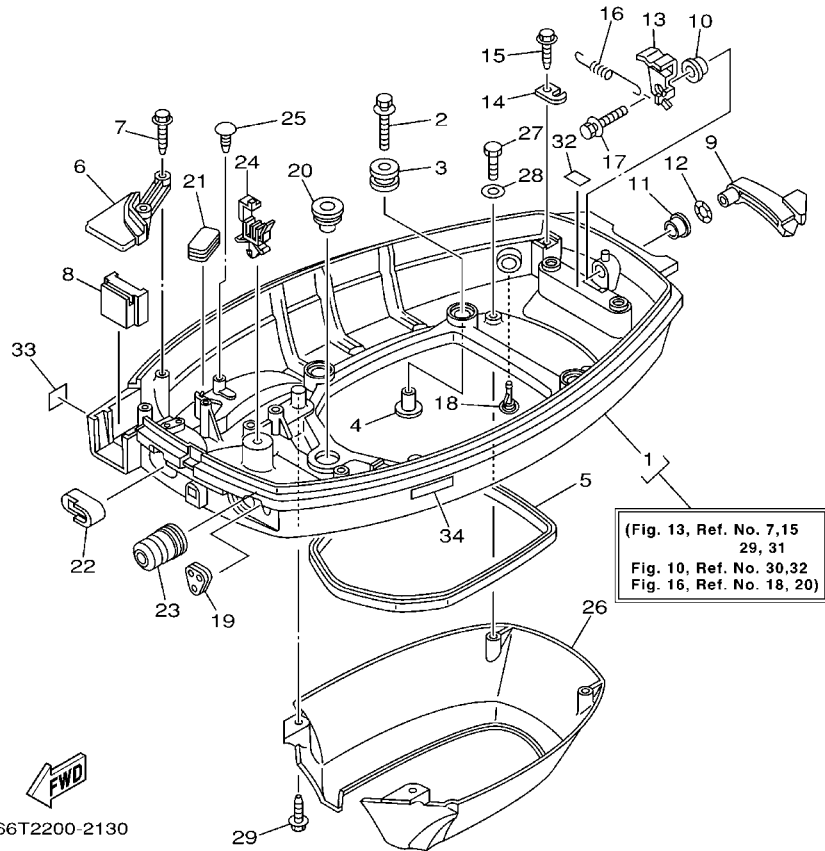
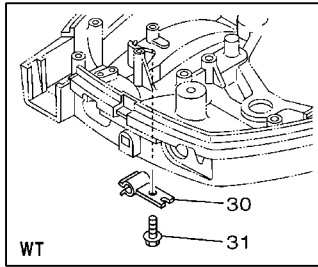
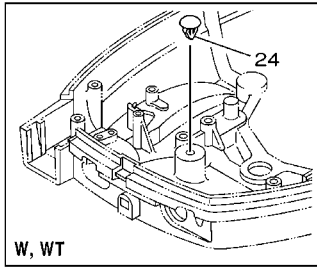

FIG. 13 BOTTOM COWLING

CUBIERTA INFERIOR

REF. NO.	PART NO. CODIGO Nº	DESCRIPTION DESCRIPCION	MH	WH	W	WT	REMARKS OBSERVACIONES
1	66T-42710-01-4D	BOTTOM COWLING ASSY CUBIERTA INFERIOR COMPL.	1	1	1	1	
2	90119-06M61	BOLT, WITH WASHER TORNILLO CON ARANDELA	4	4	4	4	
3	90480-09M21	GROMMET TAPON	4	4	4	4	
4	90387-06035	COLLAR ESPACIADOR	4	4	4	4	
5	66T-42716-00	RUBBER, SEAL 1 SELLO DE GOMA 1	1	1	1	1	
6	66T-42738-00-5B	PLATE, FITTING PLACA DE AJUSTE	1	1	1	1	
7	90109-06M81	BOLT PERNO	2	2	2	2	
8	66T-42725-00	GROMMET TAPON	1				
	66T-42725-10	GROMMET TAPON		1			
	66T-42725-20	GROMMET TAPON			1	1	
9	66T-42815-01-4D	LEVER, CLAMP PALANCA ABRAZADERA	1	1	1	1	
10	90386-12M37	BUSH BUJE	1	1	1	1	
11	90386-12MA2	BUSH BUJE	1	1	1	1	
12	90206-12052	WASHER, WAVE ARANDELA ONDULADA	1	1	1	1	
13	66T-42816-00	LEVER, CLAMP PALANCA ABRAZADERA	1	1	1	1	
14	66T-43144-00	HOOK, SPRING GANCHO	1	1	1	1	
15	90109-06M86	BOLT PERNO	1	1	1	1	
16	90506-16M34	SPRING, TENSION RESORTE DE TENSION	1	1	1	1	
17	90119-06M73	BOLT, WITH WASHER TORNILLO CON ARANDELA	1	1	1	1	
18	6E5-44391-00	NIPPLE, HOSE NIPLE MANGUERA	1	1	1	1	
19	65W-26326-00	GROMMET TAPON PROTECTOR	1	1			
	65W-26326-10	GROMMET TAPON PROTECTOR			1	1	
20	676-42727-00	GROMMET TAPON	1	1	1	1	
21	6H4-42726-00	GROMMET TAPON	1	1	1		
	6H1-42726-10	GROMMET TAPON				1	
22	66T-24329-00	SEAL SELLO	1	1	1	1	
23	65W-42726-00	GROMMET TAPON	1	1			

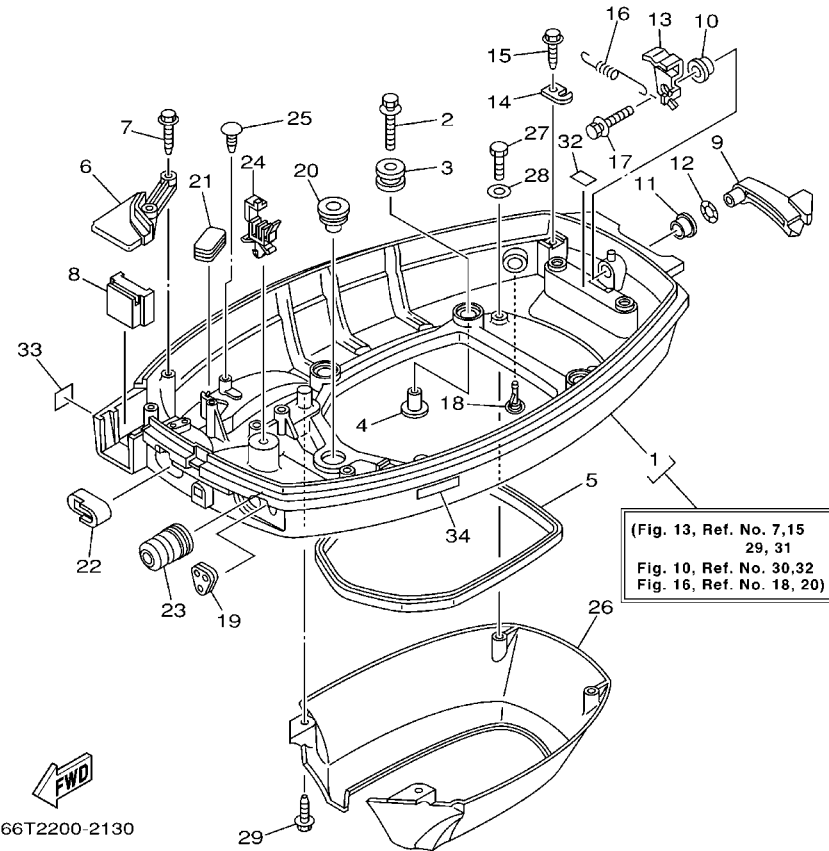
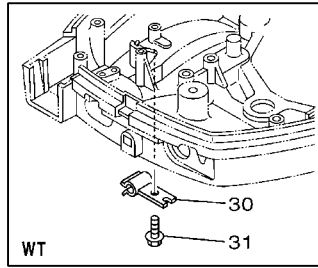
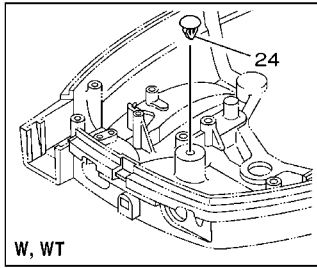

FIG. 13 BOTTOM COWLING

CUBIERTA INFERIOR

REF. NO.	PART NO. CODIGO Nº	DESCRIPTION DESCRIPCION	MH	WH	W	WT	REMARKS OBSERVACIONES
23	65W-42726-10	GROMMET TAPON			1	1	
24	90465-25M57	CLAMP BRIDA	1	1			
	90338-07M00	PLUG TAPON			1	1	
25	90338-05M03	PLUG TAPON	1	1	1		
26	66T-42741-00	APRON MANDIL	1	1	1	1	
27	97095-06016	BOLT PERNO	2	2	2	2	
28	92995-06600	WASHER ARANDELA	2	2	2	2	
29	90109-06M80	BOLT PERNO	2	2	2	2	
30	90464-09M49	CLAMP BRIDA				1	
31	90109-06M80	BOLT PERNO				1	
32	664-42791-00	MARK 1 MARCA 1	1	1	1	1	
	664-42791-10	MARK 1 MARCA 1	1	1	1	1	FOR CAR(CE),CHN FOR CAR(CE),CHN
33	6A1-28176-00	LABEL, CAUTION ETIQUETA DE PRECAUCION	1	1			FOR CAR(CE) FOR CAR(CE)
34	6E3-8257H-00	PLATE, MARK PLACA DE MARCA	1	1			FOR CAR(CE) FOR CAR(CE)

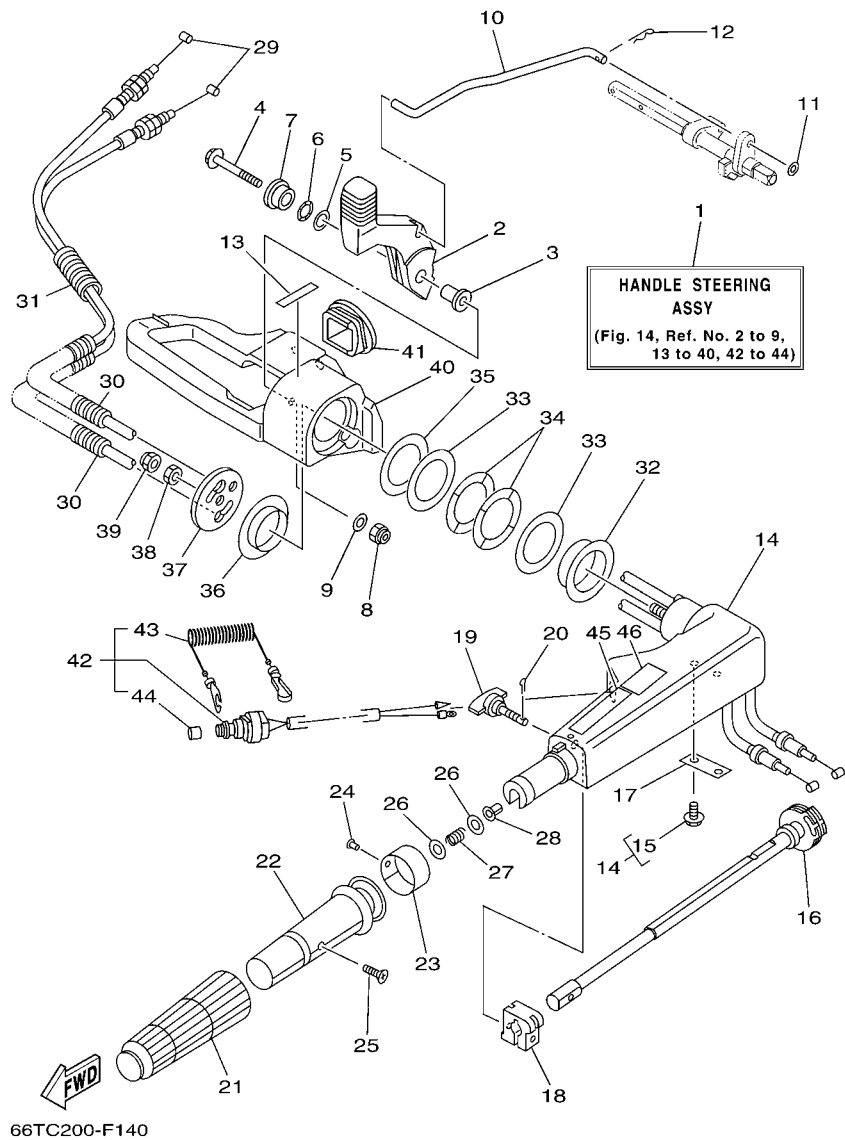

FIG. 14 STEERING

DIRECCION

REF. NO.	PART NO. CODIGO Nº	DESCRIPTION DESCRIPCION	MH	WH	W	WT	REMARKS OBSERVACIONES
1	66T-W0084-02-4D	HANDLE STEERING ASSY CONJUNTO DE MANIJA	1	1			
2	66T-44111-02	HANDLE, GEAR SHIFT MANIJA DE CAMBIO DE MARCHAS	1	1			
3	90387-06M86	COLLAR ESPACIADOR	1	1			
4	97595-06550	BOLT, WITH WASHER PERNO CON ARANDELA	1	1			
5	90201-12M07	WASHER, PLATE ARANDELA PLANA	1	1			
6	90206-12052	WASHER, WAVE ARANDELA ONDULADA	1	1			
7	66T-42123-00	BOLT, HANDLE JOINT TORNILLO CONEXION DE LA MANIJA	1	1			
8	95780-06300	NUT, FLANGE TUERCA	1	1			
9	92995-06200	WASHER ARANDELA	1	1			
10	66T-44124-00	LINK, SHIFT ROD ESLABON	1	1			
11	92990-06200	WASHER, PLAIN ARANDELA PLANA	1	1			
12	90468-18008	CLIP PRESILLA	1	1			
13	6E0-44191-11	INDICATOR, SHIFT INDICADOR DE CAMBIOS	1	1			
14	65W-42101-01-4D	HANDLE, STEERING MANIJA DE DIRECCION	1	1			
15	90109-06M86	.BOLT .PERNO	2	2			
16	65W-42138-00	LEVER, THROTTLE PLANCA DE ACELERACION	1	1			
17	65W-42159-00	STAY SOPORTE	1	1			
18	6G1-42126-00	FRICTION, STEERING HANDLE GRIP FRICCION DE MANGO DIRECCION	1	1			
19	65W-42125-00	BOLT, FRICTION ADJUSTING TORNILLO FRICCION ADJUSTA	1	1			
20	91490-20010	PIN, COTTER CHAVETA	1	1			
21	6F6-42177-A0	RUBBER, HANDLE HULE DE MANIJA	1	1			
22	664-42119-00	GRIP, STEERING HANDLE MANGO, MANIJA DE DIRRECCION	1	1			
23	6G1-42137-10	INDICATOR, THROTTLE INDICADOR ACELERADOR	1	1			
24	90269-02M09	RIVET REMACHE	1	1			
25	90149-05M13	SCREW TORNILLO DE REGLAJE	1	1			
26	90201-10M02	WASHER, PLATE ARANDELA PLANA	2	2			
27	90501-23215	SPRING, COMPRESSION RESORTE DE COMPRESION	1	1			

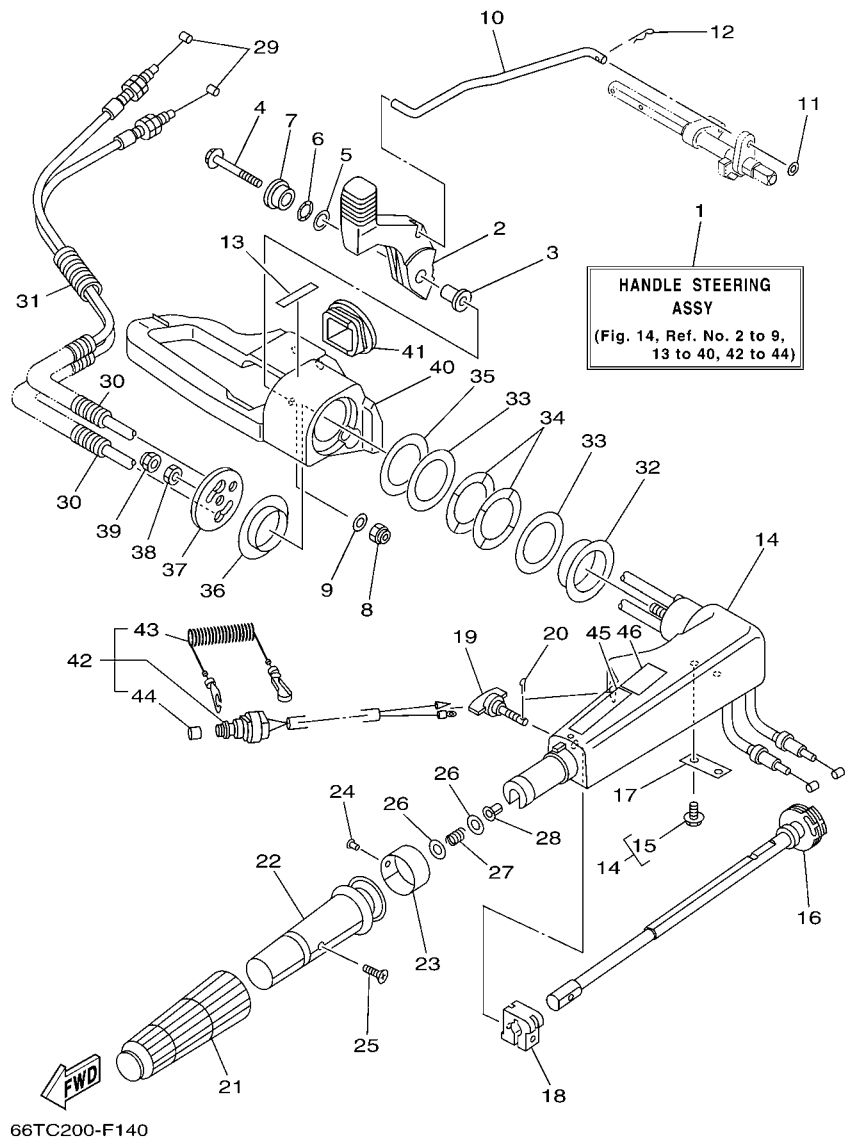

FIG. 14 STEERING

DIRECCION

REF. NO.	PART NO. CODIGO Nº	DESCRIPTION DESCRIPCION	MH	WH	W	WT	REMARKS OBSERVACIONES
28	90386-08032	BUSH BUJE	1	1			
29	66T-26301-00	THROTTLE CABLE ASSY CABLE DE ACELERADOR COMPLETO	2	2			
30	90446-10M87	HOSE (L75) TUBO (L75)	2	2			
31	90446-10M86	HOSE (L140) TUBO (L140)	2	2			
32	90386-40MA0	BUSH BUJE	1	1			
33	90201-43M00	WASHER, PLATE ARANDELA PLANA	2	2			
34	90206-43M22	WASHER, WAVE ARANDELA ONDULADA	2	2			
35	90202-43M57	WASHER, PLATE ARANDELA DE PLANA	1	1			
36	90386-40M99	BUSH BUJE	1	1			
37	65W-42131-01	COVER, HANDLE STEERING CUBIERTA MANIJA DIRRECCION	1	1			
38	95380-10700	NUT TUERCA	1	1			
39	95780-10300	NUT, FLANGE TUERCA	1	1			
40	65W-42121-01-4D	BRACKET SOPORTE	1	1			
41	66T-41273-00	GROMMET TAPON PROTECTOR	1	1			
42	66T-82575-01	ENGINE STOP SWITCH ASSY INTERRUPTOR DE PARADA COMPL	1	1			
43	682-82556-00	.LANYARD, STOP SWITCH .RETENER	1	1			
44	689-8257Y-00	.CAP .CASQUILLO	1	1			
45	6E0-83627-41	LABEL, CAUTION 7 ETIQUETA DE PRECAUCION 7	1	1			
46	61T-83627-80	LABEL, CAUTION 7 ETIQUETA DE PRECAUCION 7	1				FOR RUS FOR RUS

FIG. 15 STEERING FRICTION

FRICCION DE DIRECCION

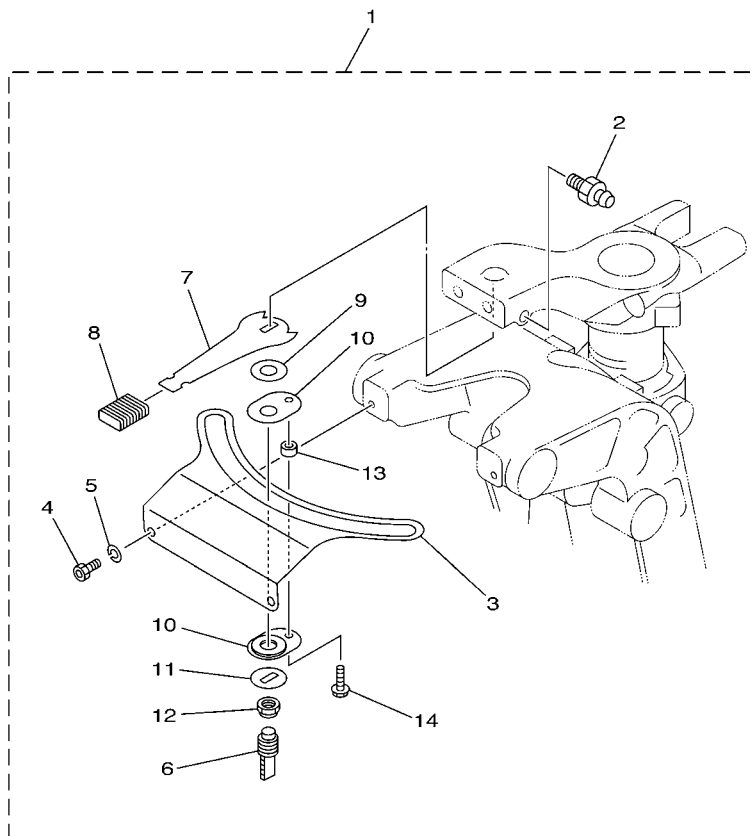

REF. NO.	PART NO. CODIGO Nº	DESCRIPTION DESCRIPCION	MH	WH	W	WT	REMARKS OBSERVACIONES
1	65W-42508-00	STEERING FRICTION ASSY DIRECCION FRICCION COMP.	1				
2	93700-06M03	.NIPPLE, GREASE .BOQUILLA DE ENGRASAR	1				
3	65W-42527-00	.PLATE, FRICTION .PLACA DE FRICCION	1				
4	90109-06M88	.BOLT .PERNO	2				
5	92990-06100	.WASHER, SPRING .ARANDELA PLANA	2				
6	65W-42562-00	.SHAFT, STEERING LOCK .EJE, CERRADURA DE DIRECCION	1				
7	65W-42561-00	.KNOB, STEERING LOCK .PERILLA	1				
8	689-43633-00	.COVER, TILT LEVER .CUBIERTA PALANCA DE INCLINAC	1				
9	90202-10M56	.WASHER, PLATE .ARANDELA DE PLANA	1				
10	65W-42528-00	.PLATE, FRICTION .PIEZA DE FRICCION	2				
11	90209-10M26	.WASHER .ARANDELA DE SEPARACION	1				
12	90185-10M14	.NUT, SELF-LOCKING .TUERCA AUTOBLOCANTE	1				
13	90387-05M11	.COLLAR .ESPACIADOR	1				
14	90109-05M89	.BOLT .PERNO	1				



65W1010-2180

FIG. 16 CONTROL

CONTROL

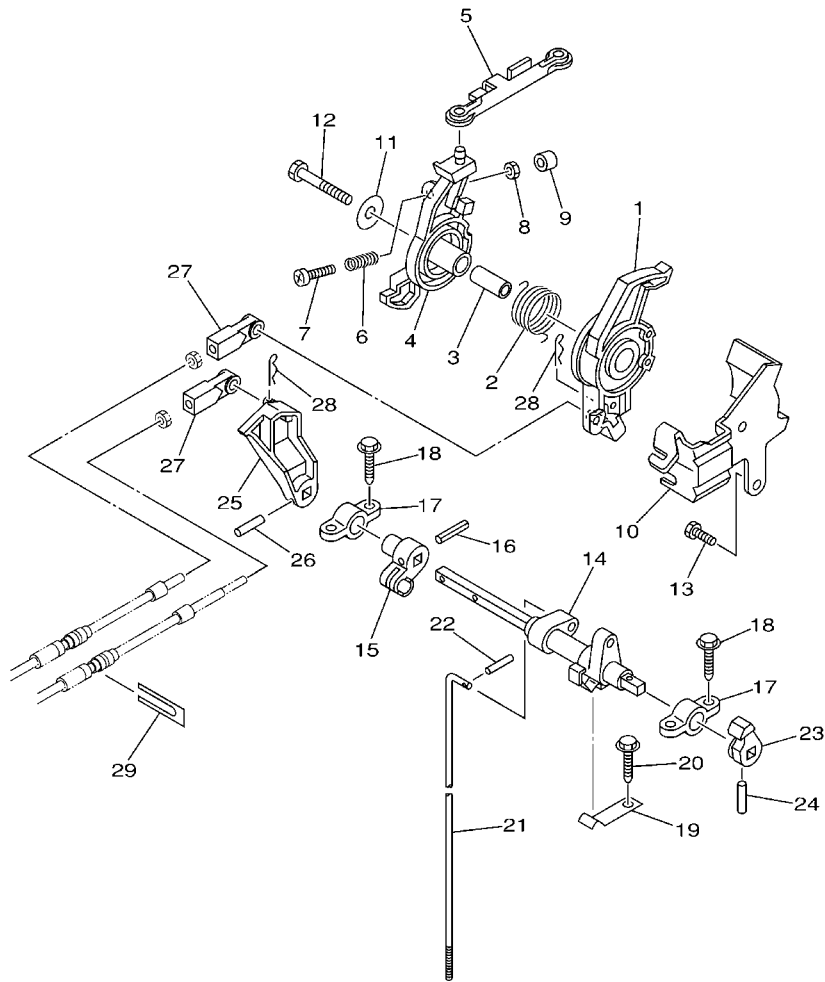

REF. NO.	PART NO. CODIGO Nº	DESCRIPTION DESCRIPCION	MH	WH	W	WT	REMARKS OBSERVACIONES
1	66T-41638-00	PULLEY POLEA	1	1	1	1	
2	66T-42167-00	SPRING 1 RESORTE 1	1	1	1	1	
3	90387-08M16	COLLAR ESPACIADOR	1	1	1	1	
4	66T-41631-01	LEVER, MAGNETO CONTROL PALANCA DE CONTROL DE MAGNETO	1	1	1	1	
5	66T-41237-00	JOINT, LINK CONECTOR	1	1	1	1	
6	90501-10M84	SPRING, COMPRESSION RESORTE DE COMPRESION	1	1	1	1	
7	97880-06035	SCREW, PAN HEAD TORNILLO DE CABEZA CON PLANA	1	1	1	1	
8	95380-06700	NUT TUERCA	1	1	1	1	
9	688-44194-00	CAP TAPA	1	1	1	1	
10	66T-14497-00	STAY, THROTTLE WIRE SOPORTE VALVULA DE OBTURACION	1	1	1	1	
11	90201-08M54	WASHER, PLATE ARANDELA PLANA	1	1	1	1	
12	97095-08045	BOLT PERNO	1	1	1	1	
13	97095-06014	BOLT PERNO	1	1	1	1	
14	66T-44121-00	LEVER, SHIFT ROD PALANCA VARILLA CAMBIOS	1	1	1	1	
15	66M-44122-00	BUSHING, SHIFT ROD LEVER BUJE PALANCA VARILLA DE CAMBIO	1	1	1	1	
16	90254-03M05	PIN, SPRING PASADOR DE TIPO A RESORTE	1	1	1	1	
17	6F5-41662-00	BRACKET SOPORTE	2	2	2	2	
18	90109-06M81	BOLT PERNO	4	4	4	4	
19	682-44116-01	SPRING RESORTE	1	1	1	1	
20	90109-06M80	BOLT PERNO	1	1	1	1	
21	66T-44143-00	ROD, SHIFT VARILLA DE CAMBIO	1		1		S(16.7") S(16.7")
	66T-44143-10	ROD, SHIFT VARILLA DE CAMBIO	1	1	1	1	L(21.7"),X(25.6") L(21.7"),X(25.6")
22	91490-16012	PIN, COTTER CHAVETA	1	1	1	1	
23	65W-44173-00	LEVER, SHIFT CONTROL PALANCA CONTROL CAMBIOS		1	1		W-FOR RUS W-FOR RUS
24	90254-03M04	PIN, SPRING PASADOR DE TIPO A RESORTE		1	1		W-FOR RUS W-FOR RUS
25	66T-44125-01	LEVER, SHIFT ROD PALANCA VARILLA CAMBIOS	1	1	1	1	
26	90254-03M04	PIN, SPRING PASADOR DE TIPO A RESORTE	1	1	1	1	

66T0010-1160

D6

FIG. 17 REMO CON ATTACHMENT

CONJUNTO ADITAMENTO

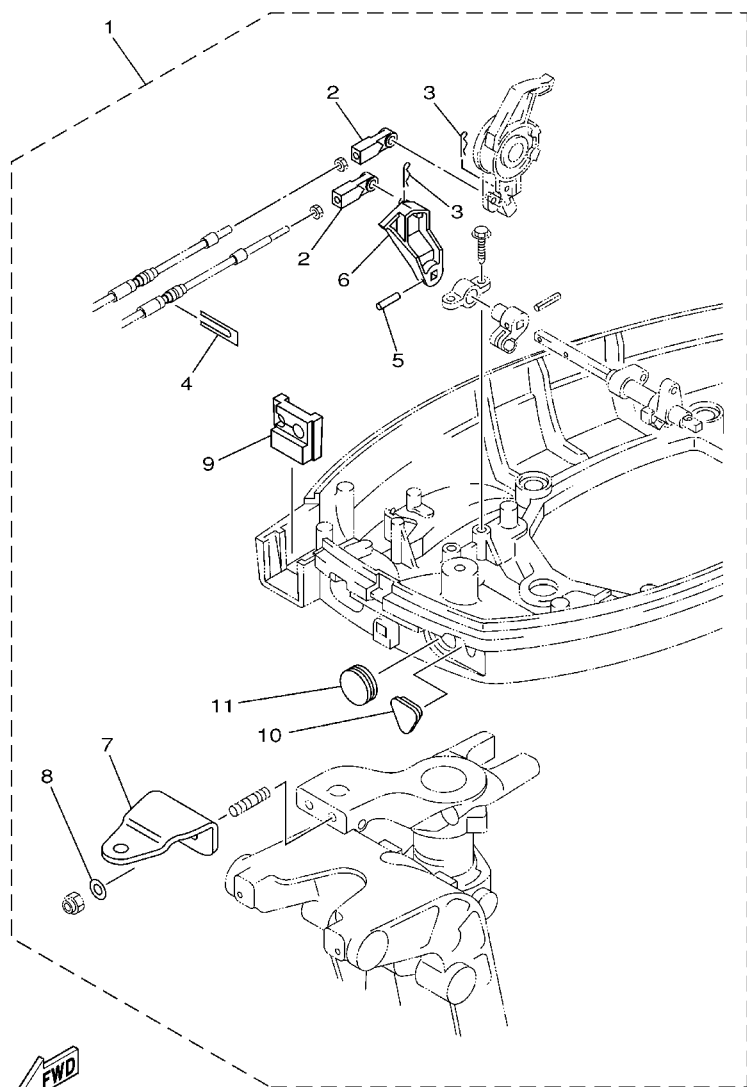

66T0010-1170

REF. NO.	PART NO. CODIGO Nº	DESCRIPTION DESCRIPCION	MH	WH	W	WT	REMARKS OBSERVACIONES
1	66T-48501-01	REMOTE CONT. ATTACHMENT ASSY. CONJUNTO ADITAMENTO	1	1			AP AP
2	663-48344-00	.CABLE END, REMOTE CONTROL .BASE CONTROL	2	2			
3	90468-18008	.CLIP .PRESILLA	2	2			
4	6H3-48538-00	.CLAMP, CABLE 1 .GRAMPA DE CABLE	1	1			
5	90254-03M04	.PIN, SPRING .PASADOR DE TIPO A RESORTE	1	1			
6	66T-44125-01	.LEVER, SHIFT ROD .PALANCA VARILLA CAMBIOS	1	1			
7	65W-48511-00	.HOOK, STEERING .GANCHO DIRECCION	1	1			
8	90201-10120	.WASHER, PLATE .ARANDELA PLANA	2	2			
9	66T-42725-30	.GROMMET .TAPON	1	1			
10	65W-26326-10	.GROMMET .TAPON PROTECTOR	1	1			
11	65W-42726-10	.GROMMET .TAPON	1	1			

FIG. 18 BRACKET 1

SOPORTE 1

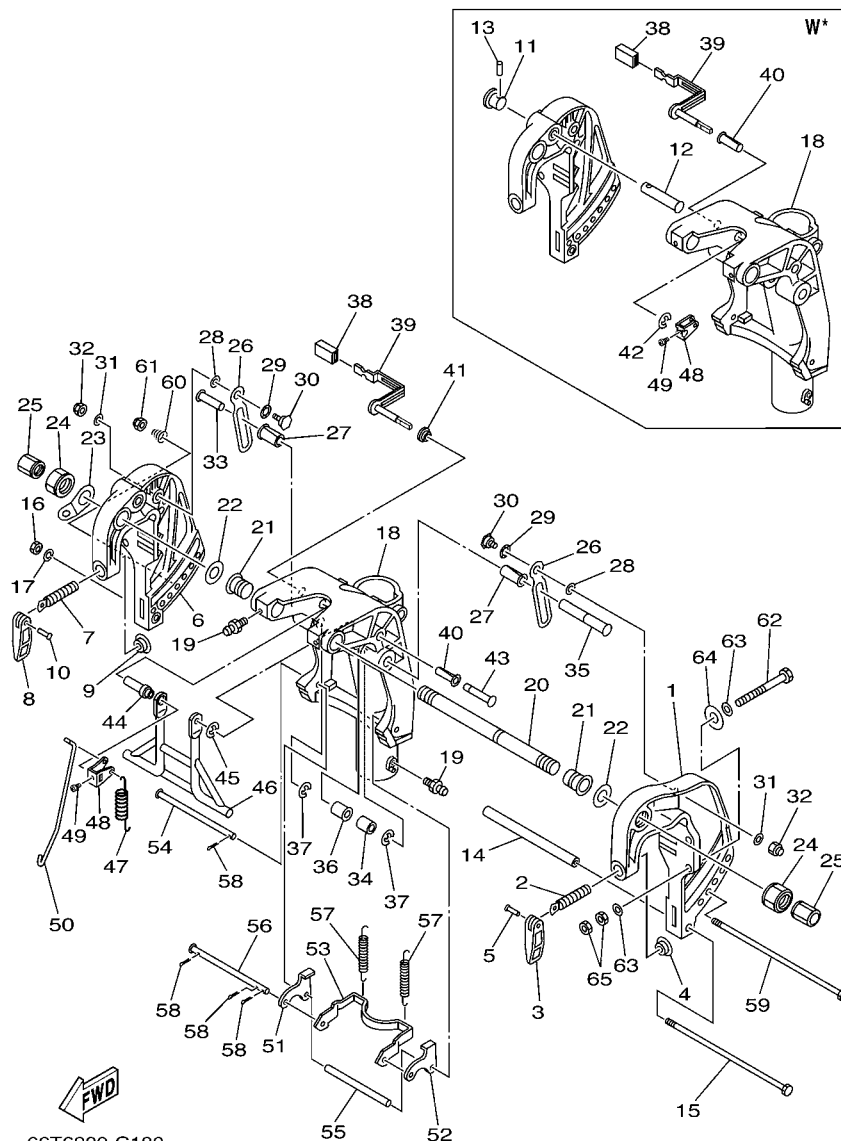

66T6200-C180

D*:FOR SHALLOW WATER DRIVE
 D*:PARA NAVEGACION EN AGUAS POCO PROFUNDAS
 W*:WITHOUT SHALLOW WATER DRIVE
 W*:SIN NAVEGACION EN AGUAS POCO PROFUNDAS

REF. NO.	PART NO. CODIGO Nº	DESCRIPTION DESCRIPCION	MH	WH	W	WT	REMARKS OBSERVACIONES
1	66T-43111-01-4D	BRACKET, CLAMP 1 SOPORTE DE LA ABRAZADERA 1	1	1	1		
2	90149-14M12	SCREW TORNILLO DE REGLAJE	1	1	1		
3	663-43118-01-4D	HANDLE, TRANSOM CLAMP MANIJA DE LA ABRAZADERA DEL ES	1	1	1		
4	648-43114-01	PAD, TRANSOM CLAMP ARANDELA DE ABRAZADERA	1	1	1		
5	90243-04007	PIN PASADOR	1	1	1		
6	66T-43112-01-4D	BRACKET, CLAMP 2 SOPORTE DE LA ABRAZADERA 2	1	1	1		
7	90149-14M12	SCREW TORNILLO DE REGLAJE	1	1	1		
8	663-43118-01-4D	HANDLE, TRANSOM CLAMP MANIJA DE LA ABRAZADERA DEL ES	1	1	1		
9	648-43114-01	PAD, TRANSOM CLAMP ARANDELA DE ABRAZADERA	1	1	1		
10	90243-04007	PIN PASADOR	1	1	1		
11	65W-43192-00	KNOB, STOPPER PERILLA DE TOPE	1	1	1		W* W*
12	65W-43191-00	SHAFT, STOPPER EJE DE TOPE	1	1	1		W* W*
13	91690-30018	PIN, SPRING PASADOR DE RESORTE	1	1	1		W* W*
14	90387-08M29	COLLAR ESPACIADOR	1	1	1		
15	90101-08M76	BOLT TORNILLO	1	1	1		
16	95380-08600	NUT TUERCA	1	1	1		
17	92990-08100	WASHER, SPRING ARANDELA PLANA	1	1	1		
18	65W-43311-00-4D	BRACKET, SWIVEL 1 SOPORTE GIRATORIO 1	1		1		S(16.7") S(16.7")
	65W-43311-10-4D	BRACKET, SWIVEL 1 SOPORTE GIRATORIO 1	1	1	1		L(21.7"),X(25.6") L(21.7"),X(25.6")
19	93700-06M03	NIPPLE, GREASE BOQUILLA DE ENGRASAR	1				WITH STEERING FRICTION WITH STEERING FRICTION
	93700-06M03	NIPPLE, GREASE BOQUILLA DE ENGRASAR	3	3	3		
20	63D-43131-01	BOLT, CLAMP BRACKET TORNILLO DE ABRAZADERA DEL SOP	1	1	1		
21	90386-22M15	BUSH BUJE	2	2	2		
22	90201-22M03	WASHER, PLATE ARANDELA PLANA	2	2	2		
23	6J8-43113-01	PLATE, CLAMP BRACKET PLACA ABRAZADERA SOPORTE	1	1	1		
24	90185-22043	NUT, SELF-LOCKING TUERCA AUTOBLOCANTE	2	2	2		
25	6G5-43145-01	CAP, CLAMP BRACKET TAPA	2	2	2		

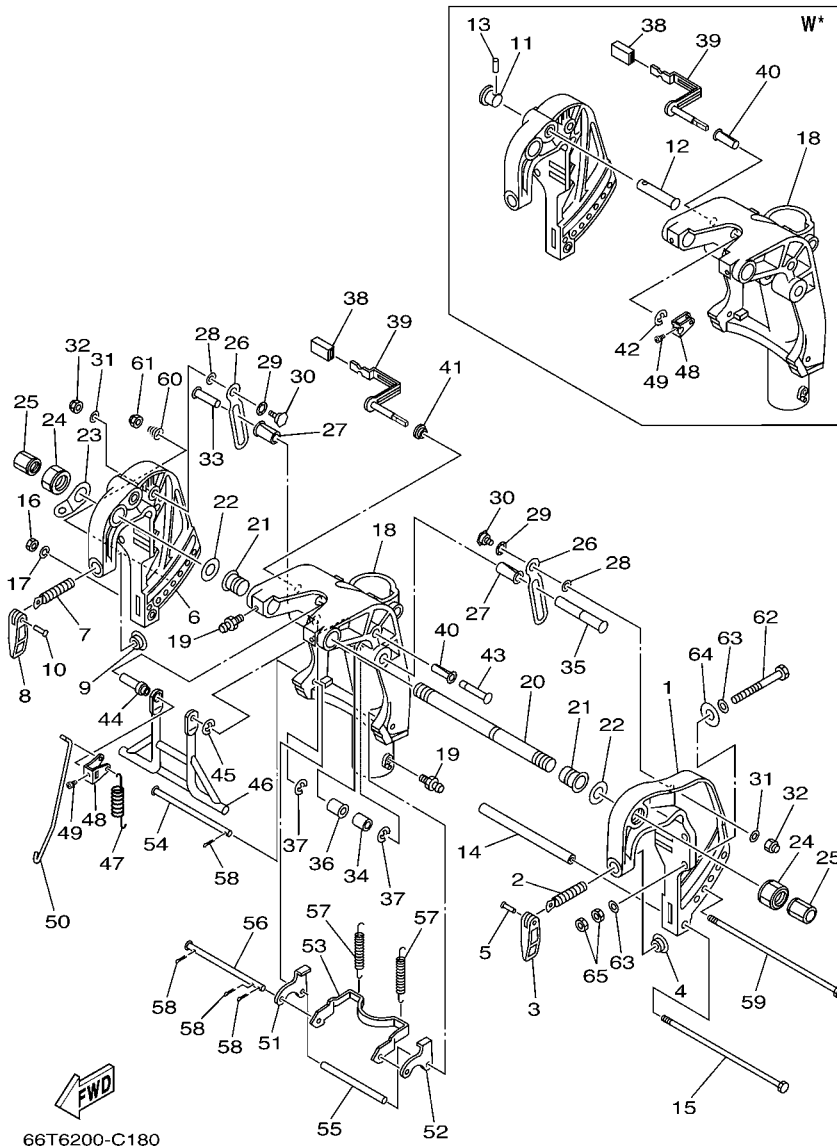

D*:FOR SHALLOW WATER DRIVE
 D*:PARA NAVEGACION EN AGUAS POCO PROFUNDAS
 W*:WITHOUT SHALLOW WATER DRIVE
 W*:SIN NAVEGACION EN AGUAS POCO PROFUNDAS

FIG. 18 BRACKET 1

SOPORTE 1

REF. NO.	PART NO. CODIGO Nº	DESCRIPTION DESCRIPCION	MH	WH	W	WT	REMARKS OBSERVACIONES
26	66T-43627-00	STOPPER RETEN	2	2	2		
27	90386-12M98	BUSH BUJE	2	2	2		
28	90202-12031	WASHER, PLATE ARANDELA DE PLANA	2	2	2		
29	90206-12M00	WASHER, WAVE ARANDELA ONDULADA	2	2	2		
30	90109-08M90	BOLT PERNO	2	2	2		
31	90201-08M07	WASHER, PLATE ARANDELA PLANA	2	2	2		
32	90185-08057	NUT, SELF-LOCKING TUERCA AUTOBLOCANTE	2	2	2		
33	90249-12M34	PIN PASADOR	1	1	1		D*
	90249-12M34	PIN PASADOR	2	2	2		W*
34	90387-12M04	COLLAR ESPACIADOR	1	1	1		D*
35	90249-12M39	PIN PASADOR	1	1	1		D*
36	90386-12MA0	BUSH BUJE	1	1	1		D*
37	93430-10M00	CIRCLIP SEGURO	2	2	2		
38	682-43318-01	COVER CUBIERTA	1	1	1		
39	65W-43630-11	TILT LEVER ASSY PLANCA DE INCLINACION COMPL	1	1	1		D*
	65W-43630-02	TILT LEVER ASSY PLANCA DE INCLINACION COMPL	1	1	1		W*
40	90386-10M99	BUSH BUJE	1	1	1		
41	90386-07MA2	BUSH BUJE	1	1	1		D*
42	99080-08600	CIRCLIP PRESILLA REDONDA	1	1	1		W*
43	90249-10M31	PIN PASADOR	1	1	1		D*
44	90387-07M05	COLLAR ESPACIADOR	1	1	1		D*
45	99080-08600	CIRCLIP PRESILLA REDONDA	1	1	1		D*
46	66T-43350-02	RECEIVER ASSY RECIBIDOR COMPL	1	1	1		D*
47	90506-20M37	SPRING, TENSION RESORTE DE TENSION	1	1	1		D*
48	66T-43631-11	LEVER, TILT PALANCA DE INCLINACION	1	1	1		D*
	66T-43631-01	LEVER, TILT PALANCA DE INCLINACION	1	1	1		W*
49	90157-05014	SCREW, PAN HEAD TORNILLO CABEZA CONICA PLANA	1	1	1		W*

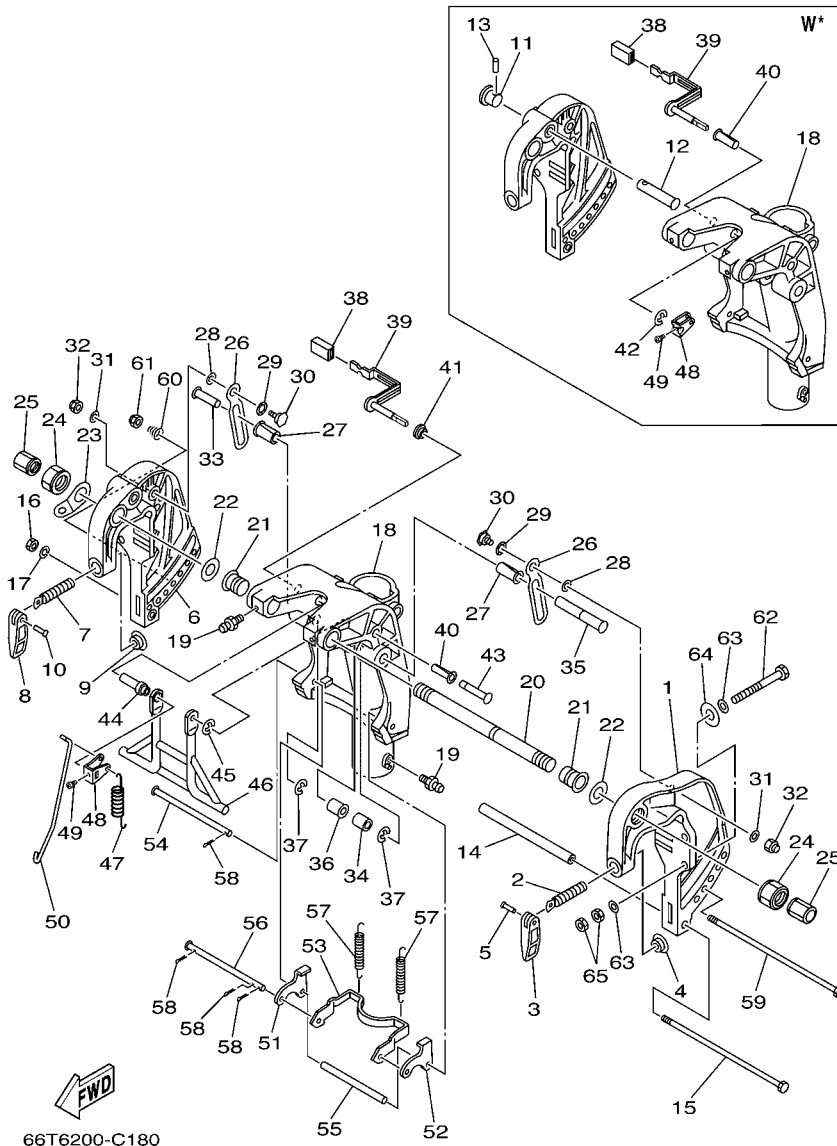

66T6200-C180

D*:FOR SHALLOW WATER DRIVE
 D*:PARA NAVEGACION EN AGUAS POCO PROFUNDAS
 W*:WITHOUT SHALLOW WATER DRIVE
 W*:SIN NAVEGACION EN AGUAS POCO PROFUNDAS

FIG. 18 BRACKET 1

SOPORTE 1

REF. NO.	PART NO. CODIGO Nº	DESCRIPTION DESCRIPCION	MH	WH	W	WT	REMARKS OBSERVACIONES
50	65W-43616-00	ROD, TILT LOCK VARILLA SEGURO DE INCLINACION	1	1	1		
51	65W-43614-01	PLATE, TILT LOCK PLACA DE SEGURO DE INCLINACION	1	1	1		
52	65W-43615-01	PLATE, TILT LOCK PLACA DE SEGURO DE INCLINACION	1	1	1		
53	65W-43613-00	ARM, TILT LOCK BRAZO DE SEGURO DE INCLINACION	1	1	1		
54	90249-07M32	PIN PASADOR	1	1	1		
55	90387-07M29	COLLAR ESPACIADOR	1	1	1		
56	90249-07M33	PIN PASADOR	1	1	1		
57	90506-30M00	SPRING, TENSION RESORTE DE TENSION	2	2	2		
58	91490-20012	PIN, COTTER CHAVETA	4	4	4		
59	90101-08M28	BOLT TORNILLO	1	1	1		
60	90502-10M06	SPRING, CONICAL RESORTE CONICO	1	1	1		
61	90185-08057	NUT, SELF-LOCKING TUERCA AUTOBLOCANTE	1	1	1		
62	90101-10M58	BOLT TORNILLO	4	4	4		
63	92995-10600	WASHER ARANDELA	8	8	8		
64	90201-12426	WASHER, PLATE ARANDELA PLANA	4	4	4		
65	95380-10600	NUT TUERCA	8	8	8		

FIG. 19 BRACKET 2

SOPORTE 2

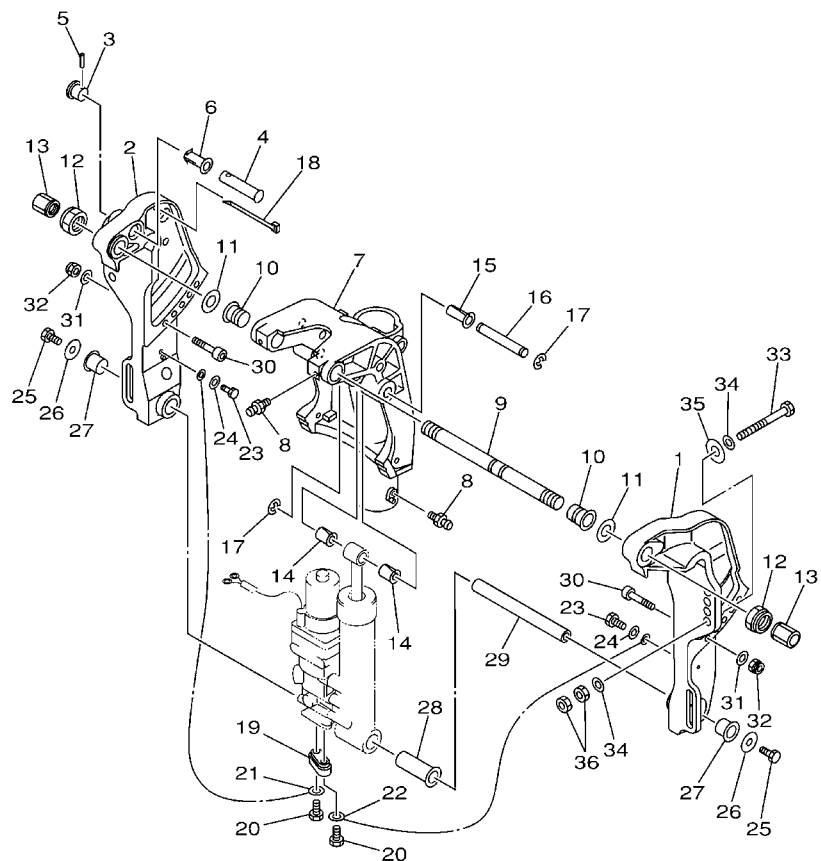

65W0010-1230

REF. NO.	PART NO. CODIGO Nº	DESCRIPTION DESCRIPCION	MH	WH	W	WT	REMARKS OBSERVACIONES
1	65W-43111-10-4D	BRACKET, CLAMP 1 SOPORTE DE LA ABRAZADERA 1				1	
2	65W-43112-10-4D	BRACKET, CLAMP 2 SOPORTE DE LA ABRAZADERA 2				1	
3	65W-43192-00	KNOB, STOPPER PERILLA DE TOPE				1	
4	65W-43191-00	SHAFT, STOPPER EJE DE TOPE				1	
5	91690-30018	PIN, SPRING PASADOR DE RESORTE				1	
6	90386-14MA1	BUSH BUJE				1	
7	65W-43311-10-4D	BRACKET, SWIVEL 1 SOPORTE GIRATORIO 1				1	L(21.7") L(21.7")
8	93700-06M03	NIPPLE, GREASE BOQUILLA DE ENGRASAR				3	
9	63D-43131-01	BOLT, CLAMP BRACKET TORNILLO DE ABRAZADERA DEL SOP				1	
10	90386-22M15	BUSH BUJE				2	
11	90201-22M03	WASHER, PLATE ARANDELA PLANA				2	
12	90185-22M11	NUT, SELF-LOCKING TUERCA AUTOBLOCANTE				2	
13	6G5-43145-01	CAP, CLAMP BRACKET TAPA				2	
14	90386-12MA0	BUSH BUJE				2	
15	90386-12M98	BUSH BUJE				1	
16	90249-12M38	PIN PASADOR				1	
17	93430-10M00	CIRCLIP SEGURO				2	
18	90465-13M11	CLAMP BRIDA				2	
19	65W-45251-00	ANODE CATODE				1	
20	90101-06020	BOLT TORNILLO				2	
21	6H1-82148-00	WIRE, LEAD 4 CABLE CONDUCTOR 4				1	
22	6U0-82127-00	WIRE, LEAD 2 CABLE CONDUCTOR 2				1	
23	97095-06014	BOLT PERNO				2	
24	92995-06600	WASHER ARANDELA				2	
25	97080-08016	BOLT PERNO				2	
26	90201-08M00	WASHER, PLATE ARANDELA PLANA				2	
27	90386-18M44	BUSH BUJE				2	

FIG. 20 BRACKET 3

SOPORTE 3

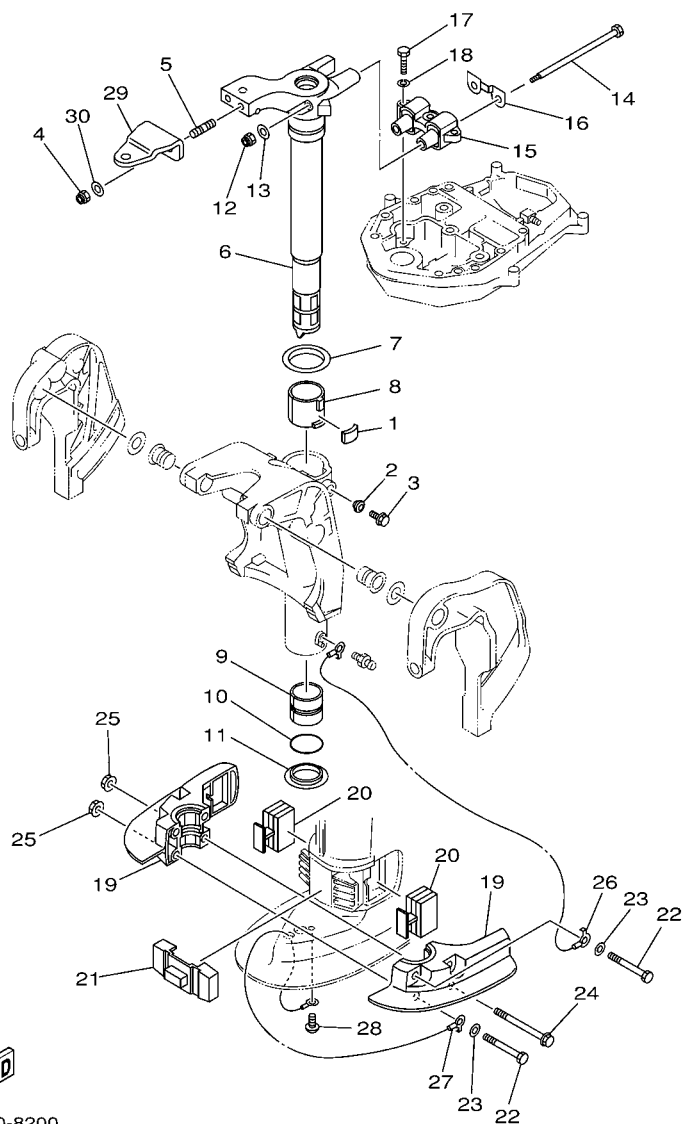

66T0010-8200

REF. NO.	PART NO. CODIGO Nº	DESCRIPTION DESCRIPCION	MH	WH	W	WT	REMARKS OBSERVACIONES
1	648-42528-00	PLATE, FRICTION PIEZA DE FRICCION	1	1	1	1	
2	65W-43373-00	SEAL, DAMPER SELLO DE GOMA	1	1	1	1	
3	90105-08M76	BOLT, FLANGE TORNILLO	1	1	1	1	
4	90185-10051	NUT, SELF-LOCKING TUERCA AUTOBLOCANTE	2	2	2	2	
5	90116-10M28	BOLT, STUD ESPARRAGO	2	2	2	2	
6	65W-42511-00-4D	BRACKET, STEERING SOPORTE DE DIRECCION	1		1		S(16.7") S(16.7")
	65W-42511-10-4D	BRACKET, STEERING SOPORTE DE DIRECCION	1	1	1	1	L(21.7"),X(25.6") L(21.7"),X(25.6")
7	90209-52M00	WASHER ARANDELA DE SEPARACION	1	1	1	1	
8	90386-52M02	BUSH BUJE	1	1	1	1	
9	90386-44M03	BUSH BUJE	1	1	1	1	
10	93210-43MJ0	O-RING ANILLO O	1	1	1	1	
11	90386-44M99	BUSH BUJE	1	1	1	1	
12	90185-08045	NUT, SELF-LOCKING TUERCA AUTOBLOCANTE	2	2	2	2	
13	92995-08200	WASHER ARANDELA	2	2	2	2	
14	90101-08M86	BOLT TORNILLO	2	2	2	2	
15	66T-44514-00-4D	MOUNT DAMPER, UPPER SIDE AMORTIGUADOR LADO SUPERIOR	1	1	1	1	S(16.7"),L(21.7") S(16.7"),L(21.7")
	66T-44514-30-4D	MOUNT DAMPER, UPPER SIDE AMORTIGUADOR LADO SUPERIOR	1				X(25.6") X(25.6")
16	66T-44526-00	PLATE PLACA 1	1	1	1	1	S(16.7"),L(21.7") S(16.7"),L(21.7")
	66T-44526-30	PLATE PLACA 1	1				X(25.6") X(25.6")
17	97075-08030	BOLT PERNO	3	3	3	3	
18	92995-08100	WASHER ARANDELA	3	3	3	3	
19	65W-44551-00-4D	HOUSING, LOWER MOUNT RUBBER CAJA AMORTIGUADOR INFERIOR HU	2	2	2	2	
20	65W-44555-10	MOUNT DAMPER, LOWER SIDE AMORTIGUADOR DE HULE LADO INFE	2	2	2	2	
21	66T-44575-00	DAMPER, LOWER MOUNT RUBBER AMORTIGUADOR INFERIOR	1	1	1	1	
22	97075-10070	BOLT PERNO	2	2	2	2	
23	92995-10600	WASHER ARANDELA	2	2	2	2	
24	90119-10M04	BOLT, WITH WASHER TORNILLO CON ARANDELA	2	2	2	2	

FIG. 20 BRACKET 3

SOPORTE 3

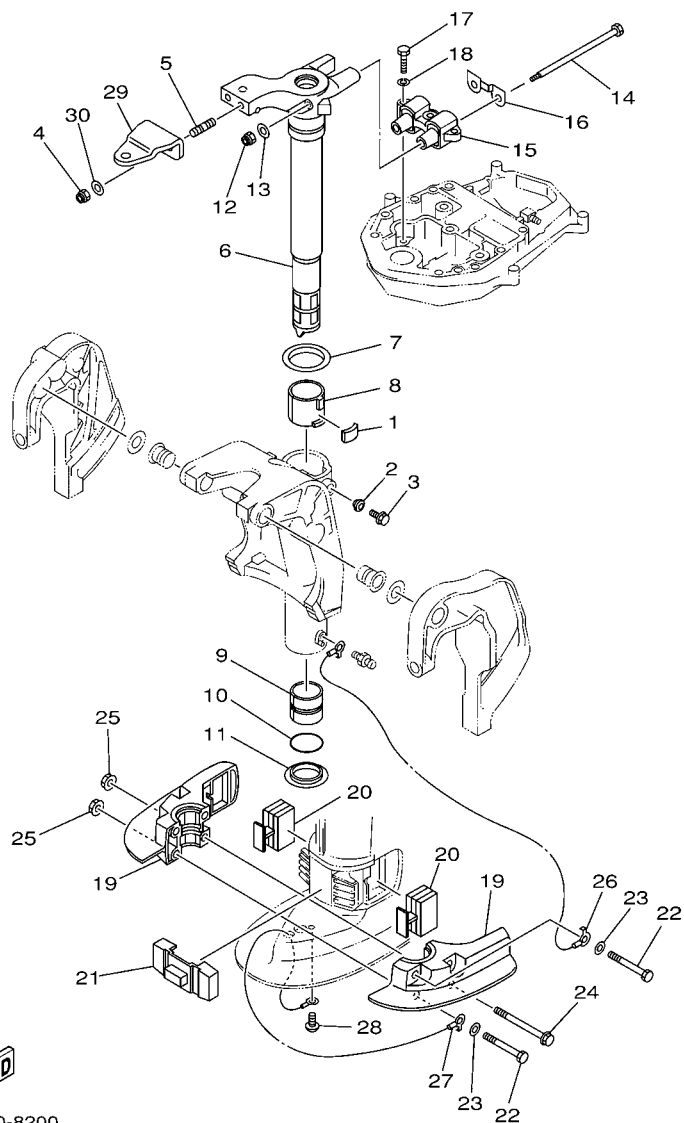

66T0010-8200

REF. NO.	PART NO. CODIGO Nº	DESCRIPTION DESCRIPCION	MH	WH	W	WT	REMARKS OBSERVACIONES
25	90179-10M33	NUT TUERCA	4	4	4	4	
26	66T-82127-00	WIRE, LEAD 2 CABLE CONDUCTOR 2	1	1	1	1	L(21.7"),X(25.6") L(21.7"),X(25.6")
27	66T-82127-10	WIRE, LEAD 2 CABLE CONDUCTOR 2	1	1	1	1	
28	97885-06008	SCREW, PAN HEAD TORNILLO A MUESCA	1	1	1	1	
29	65W-48511-00	HOOK, STEERING GANCHO DIRECCION				1	1
	670-48511-00-4D	HOOK, STEERING GANCHO DIRECCION				1	FOR RUS FOR RUS
30	90201-10120	WASHER, PLATE ARANDELA PLANA			2	2	

FIG. 21 POWER TRIM & TILT ASSY

COMPONER Y PODER VARILLA

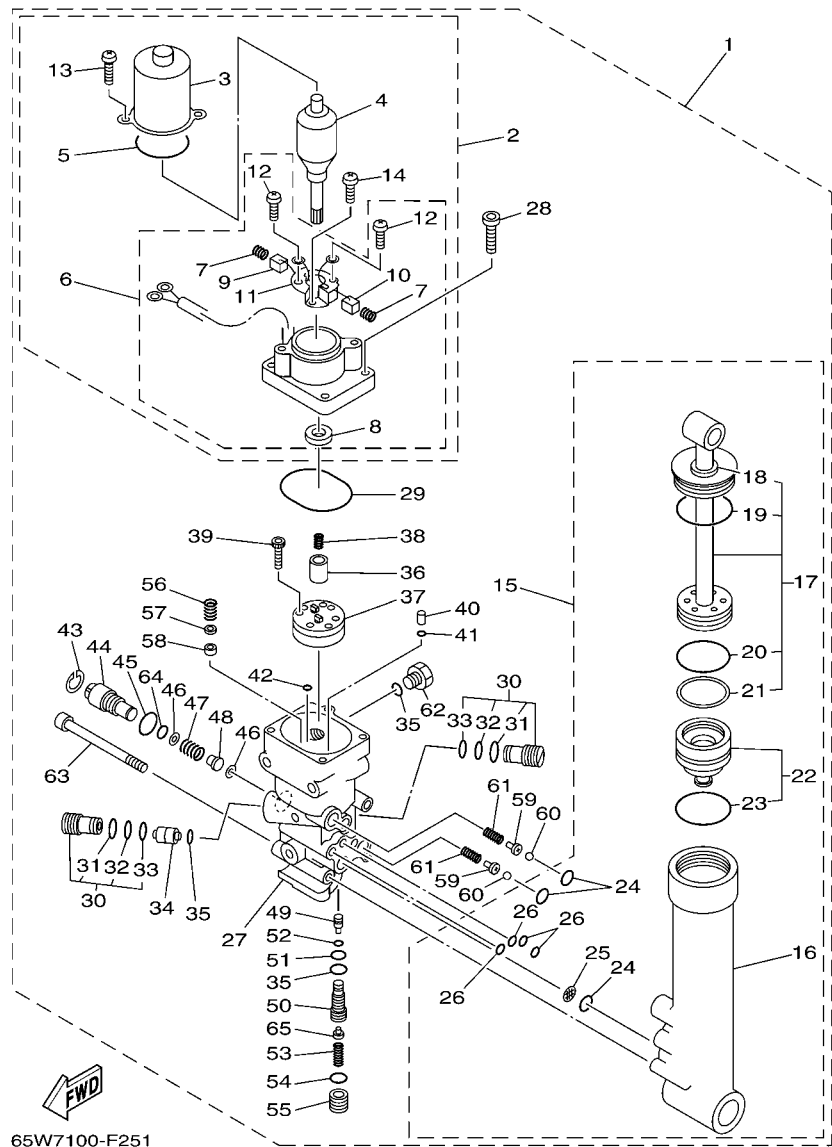

REF. NO.	PART NO. CODIGO Nº	DESCRIPTION DESCRIPCION	MH	WH	W	WT	REMARKS OBSERVACIONES
1	65W-43800-02-4D	POWER TRIM & TILT ASSY ELEVADOR HIDRAULICO COMPL.				1	
2	65W-43880-00	..MOTOR ASSY ..MOTOR COMPL.				1	
3	65W-43804-00	..STATOR ASSY ..ESTATOR COMPL				1	
4	65W-43805-00	..ARMATURE ASSY ..INDUCIDO COMPL.				1	
5	65W-43869-00	..O-RING ..ANILLO EN O 9				1	
6	65W-43881-00	..FRAME, END ..CUADRO EXTERMO				1	
7	65W-4386K-00	..SPRING, BRUSH ..RESORTE, ESCOBILLA				2	
8	65W-43882-00	..OIL SEAL ..SELLO ACEITE				1	
9	65W-43892-00	..BRUSH 2 ..ESCOBILLA 2				1	
10	65W-43891-00	..BRUSH 1 ..ESCOBILLA 1				1	
11	65W-4380F-00	..PLATE, BRUSH HOLDER ..PLACA				1	
12	65W-43879-00	..SCREW, WITH WASHER ..TORNILLO CON RONDANA				2	
13	65W-43887-00	..BOLT, THROUGH ..TORNILLO				2	
14	65W-4388E-00	..BOLT ..PERNO				1	
15	65W-43840-00	..POWER TILT ASSY ..CONJUNTO COMPONER				1	
16	65W-4380K-00	..CYLINDER, TILT SUB ASSY ..CILINDRO, INCLINACION				1	
17	65W-43810-00	..TILT PISTON SUB ASSY ..ELEVADOR SUB-PISTON COMPL.				1	
18	65W-43812-00	..SEAL, DUST ..SELLO DE POLVO				1	
19	65W-43865-00	..O-RING ..ANILLO EN O 5				1	
20	6H1-43861-10	..O-RING ..ANILLO EN O 1				1	
21	65W-43871-00	..RING, BACK UP ..ANILLO				1	
22	65W-4381B-00	..FREE PISTON SUB ASSY ..SUB-PISTON COMPL				1	
23	6H1-43861-10	..O-RING ..ANILLO EN O 1				1	
24	93210-11368	..O-RING ..ANILLO O				3	
25	6H1-43816-00	..FILTER 1 ..FIELTRO 1				1	
26	93210-064A5	..O-RING ..ANILLO O				4	
27	65W-4380L-00	..HOUSING, TRIM & TILT SUB ASSY ..CAJA, INCLINACION Y ADRNO				1	

FIG. 21 POWER TRIM & TILT ASSY

COMPONER Y PODER VARILLA

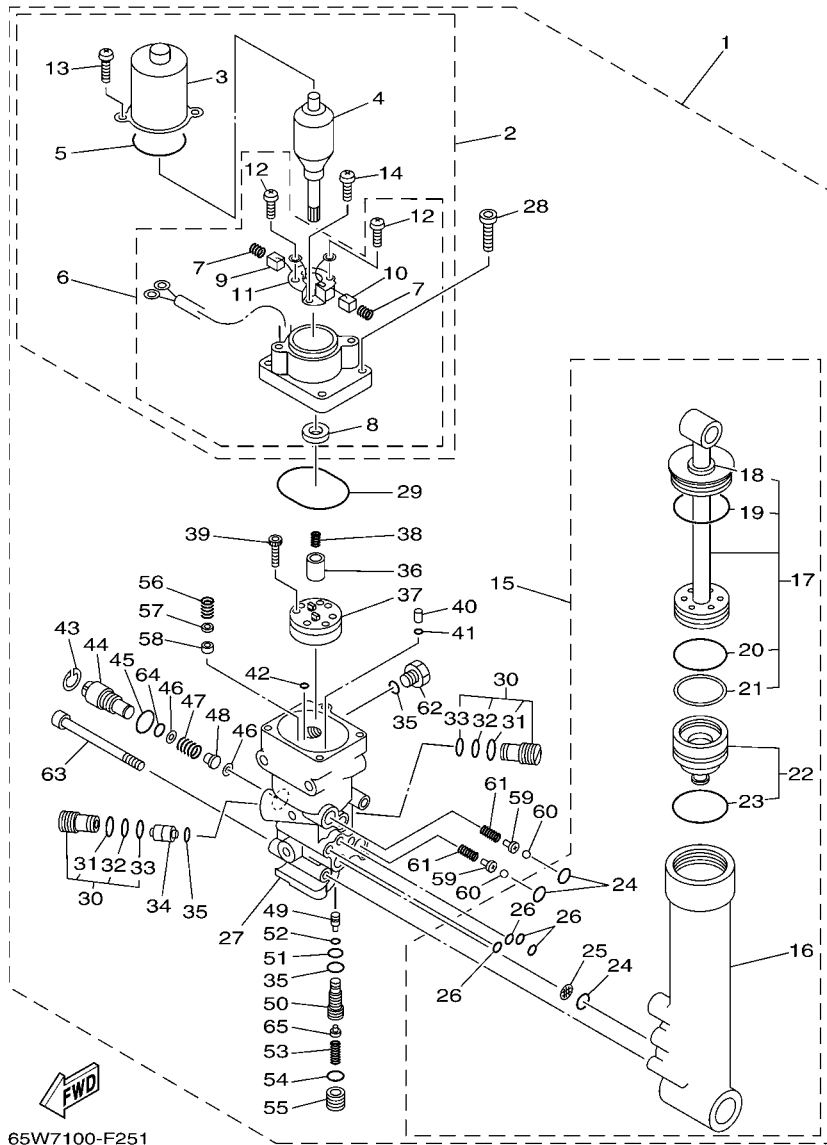

65W7100-F251

REF. NO.	PART NO. CODIGO Nº	DESCRIPTION DESCRIPCION	MH	WH	W	WT	REMARKS OBSERVACIONES
28	65W-43888-00	.BOLT, SOCKET .TORNILLO ENCASTRE				4	
29	93210-50768	.O-RING .ANILLO O				1	
30	6T4-43802-03	.VALVE SUB ASSY .VALVULA PRINCIPAL COMPL.				2	
31	6H1-43866-00	.O-RING .ANILLO EN O 6				1	
32	93210-10M74	.O-RING .ANILLO O				1	
33	6H1-43867-00	.O-RING .ANILLO EN O 7				1	
34	62X-43841-00	.PISTON, SHUTTLE .PISTON				1	
35	93210-09165	.O-RING .ANILLO O				3	
36	65W-43831-00	.CONNECTOR, SHAFT .CONEXION EJE				1	
37	65W-43830-00	.GEAR PUMP ASSY .ENGRANAJE BOMBA COMPL.				1	
38	6T4-43853-00	.SPRING, MAIN VALVE .RESORTE				1	
39	91318-04025	.BOLT .TORNILLO				4	
40	65W-43817-00	.FILTER 2 .FILTRO 2				2	
41	65W-43861-00	.O-RING .ANILLO EN O 1				2	
42	65W-43862-00	.O-RING .ANILLO EN O 2				2	
43	6H1-43875-00	.RING, SNAP .ANILLO				1	
44	6H1-43845-00	.SCREW, MANUAL RELEASE .TORNILLO DESCOPLO MANUAL				1	
45	93210-18397	.O-RING .ANILLO O				1	
46	6H1-43847-00	.SEAT, MANUAL VALVE .ASIENTO VALVULA MANUAL				2	
47	65W-43854-00	.SPRING, MANUAL RELEASE .RESORTE DESCOPLO MANUAL				1	
48	65W-4382A-00	.ADAPTOR 1 .ADAPTADOR 1				1	
49	65W-43844-00	.PIN, VALVE SUPPORT .PASADOR VALVULA SOPORTE				1	
50	65W-43851-00	.SEAT, RELIEF VALVE .ASIENTO VALVULA DE DESCARGA				1	
51	93210-08006	.O-RING .ANILLO O				1	
52	93210-03478	.O-RING .ANILLO O				1	
53	65W-43855-00	.SPRING, UP RELIEF .RESORTE SEGURIDAD SUPERIOR				1	
54	93210-11073	.O-RING .ANILLO O				1	

FIG. 22 UPPER CASING

FUNDA SUPERIOR

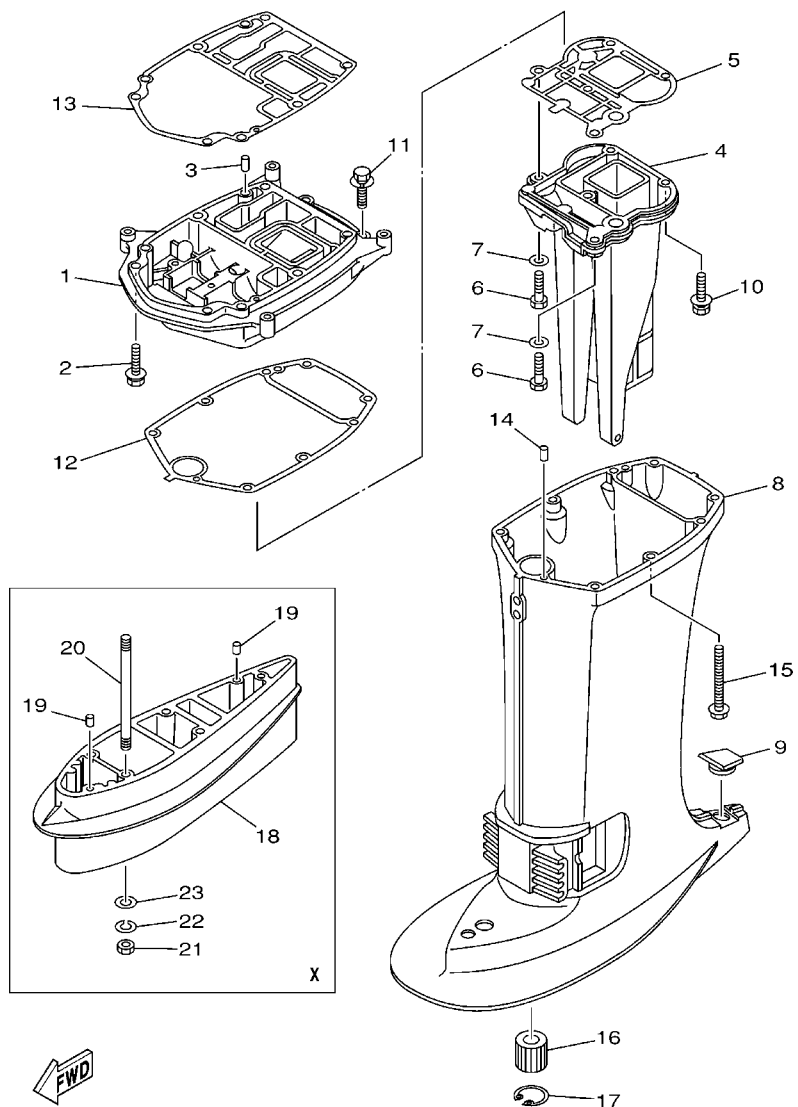

66T2200-2220

REF. NO.	PART NO. CODIGO Nº	DESCRIPTION DESCRIPCION	MH	WH	W	WT	REMARKS OBSERVACIONES
1	66T-41137-00-5B	GUIDE, EXHAUST GUIA DE ESCAPE	1	1	1	1	
2	90119-08M79	BOLT, WITH WASHER TORNILLO CON ARANDELA	2	2	2	2	
3	93606-12019	PIN, DOWEL PASADOR DE CLAVIJA	2	2	2	2	
4	66T-41131-00-5B	MANIFOLD, EXT. 1 TUBO MULTIPLE DE ESCAPE	1	1			S(16.7") S(16.7")
	66T-41131-10-5B	MANIFOLD, EXT. 1 TUBO MULTIPLE DE ESCAPE	1	1	1	1	L(21.7"),X(25.6") L(21.7"),X(25.6")
5	66T-41133-A0	GASKET, EXHAUST MANIFOLD 1 EMPAQUE ESCAPE MULTIPLE	1	1	1	1	
6	97075-08030	BOLT PERNO	2	2	2	2	
7	92995-08600	WASHER ARANDELA	2	2	2	2	
8	66T-45111-00-4D	CASING, UPPER CAJA SUPERIOR	1	1			S(16.7") S(16.7")
	66T-45111-10-4D	CASING, UPPER CAJA SUPERIOR	1	1	1	1	L(21.7"),X(25.6") L(21.7"),X(25.6")
9	63D-45155-00	CAP TAPA	1	1	1	1	
10	97575-08545	BOLT, WITH WASHER PERNO CON ARANDELA	3	3	3	3	
11	90119-08M79	BOLT, WITH WASHER TORNILLO CON ARANDELA	2	2	2	2	
12	66T-45114-A0	GASKET, UPPER CASING EMPAQUE	1	1	1	1	
13	66T-45113-A0	GASKET, UPPER CASING EMPAQUE	1	1	1	1	
14	93606-12019	PIN, DOWEL PASADOR DE CLAVIJA	2	2	2	2	
15	90119-08M42	BOLT, WITH WASHER TORNILLO CON ARANDELA	6	6	6	6	
16	679-45318-00	BUSHING, DRIVE SHAFT BUJE, EJE DE MANDO	1	1	1	1	L(21.7"),X(25.6") L(21.7"),X(25.6")
17	93420-30042	CIRCLIP SEGURO	1	1	1	1	L(21.7"),X(25.6") L(21.7"),X(25.6")
18	66T-45211-00-4D	EXTENSION EXTENSION	1				X(25.6") X(25.6")
19	93606-12019	PIN, DOWEL PASADOR DE CLAVIJA	2				X(25.6") X(25.6")
20	90116-10M23	BOLT, STUD ESPARRAGO	4				X(25.6") X(25.6")
21	95380-10600	NUT TUERCA	4				X(25.6") X(25.6")
22	92990-10100	WASHER, SPRING ARANDELA PLANA	4				X(25.6") X(25.6")
23	92990-10600	WASHER, PLATE ARANDELA PLANA	4				X(25.6") X(25.6")

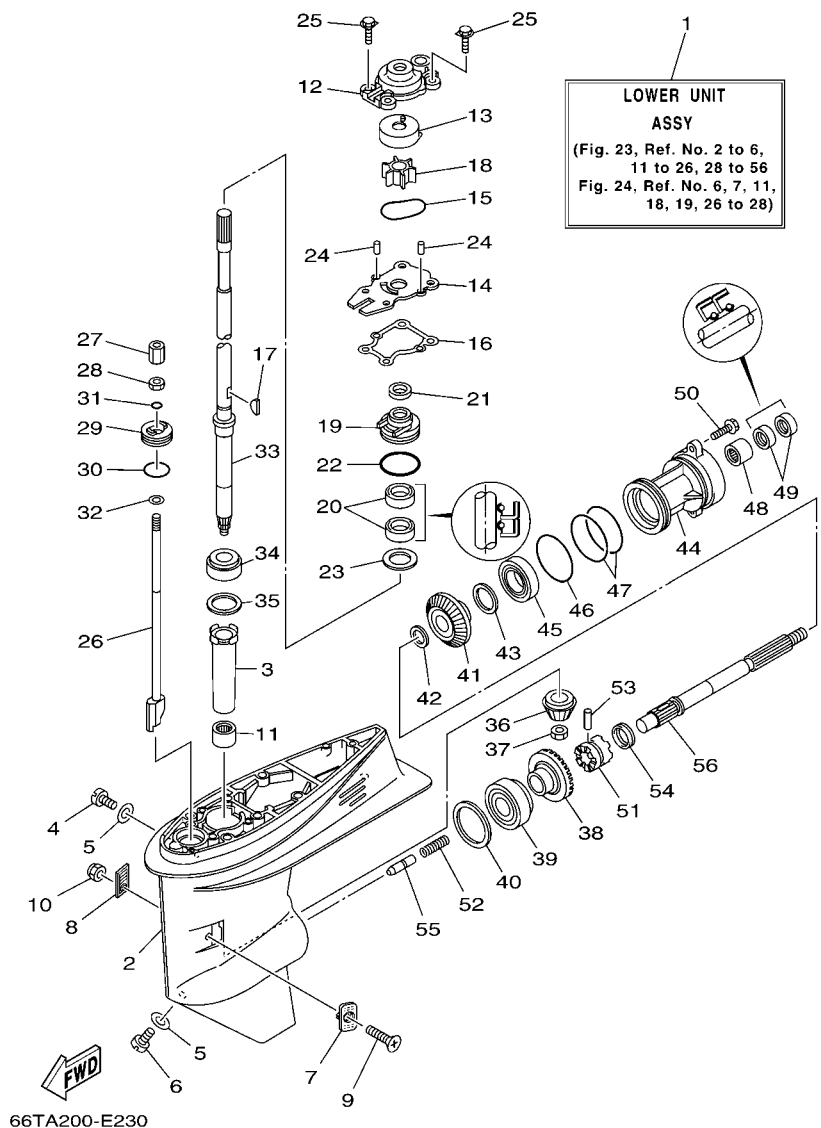

66TA200-E230

FIG. 23 LOWER CASING & DRIVE 1 IMPULSOR E INFERIOR 1

REF. NO.	PART NO. CODIGO Nº	DESCRIPTION DESCRIPCION	MH	WH	W	WT	REMARKS OBSERVACIONES
1	66T-45300-01-4D	LOWER UNIT ASSY CONJUNTO UNIDAD INFERIOR	1		1		S(16.7") S(16.7")
	66T-45300-11-4D	LOWER UNIT ASSY CONJUNTO UNIDAD INFERIOR	1	1	1	1	L(21.7") L(21.7")
	66T-45300-31-4D	LOWER UNIT ASSY CONJUNTO UNIDAD INFERIOR	1				X(25.6") X(25.6")
2	66T-45311-01-4D	CASING, LOWER FUNDA INFERIOR	1	1	1	1	
3	6H4-45536-00	SLEEVE, DRIVE SHAFT CAMISA EJE DE MANDO	1	1	1	1	
4	90340-08002	PLUG, STRAIGHT SCREW TORNILLO, DE DRENAJE	1	1	1	1	
5	90430-08020	GASKET JUNTA	2	2	2	2	
6	688-45341-10	PLUG, DRAIN TAPON, DREN	1	1	1	1	
7	63D-45214-00	COVER, WATER INLET 1 CUBIERTA ENTRADA AGUA 1	1	1	1	1	
8	63D-45215-00	COVER, WATER INLET 2 CUBIERTA ENTRADA AGUA 2	1	1	1	1	
9	90142-05M06	SCREW, COUNTERSUNK TORNILLO EMBUTIDO	1	1	1	1	
10	95380-05600	NUT TUERCA	1	1	1	1	
11	93315-32224	BEARING COJINETE DE RODILLOS	1	1	1	1	
12	66T-44311-00	HOUSING, WATER PUMP CAJA BOMBA DE AGUA	1	1	1	1	
13	63D-44322-00	INSERT, CARTRIDGE CARTUCHO				1	FOR STD FOR STD
	63D-44322-40	INSERT, CARTRIDGE CARTUCHO	1	1	1	1	FOR CHROMATE FOR CHROMATE
14	66T-44323-00	OUTER PLATE, CARTRIDGE PLACA EXTERIOR DEL CARTUCHO				1	FOR STD FOR STD
	66T-44323-40	OUTER PLATE, CARTRIDGE PLACA EXTERIOR DEL CARTUCHO	1	1	1	1	FOR CHROMATE FOR CHROMATE
15	93210-59MG7	O-RING ANILLO O	1	1	1	1	
16	63D-44316-00	GASKET, WATER PUMP EMPAQUE	1	1	1	1	
17	90280-03M03	KEY, WOODRUFF CUNA WOODRUFF	1	1	1	1	
18	6H4-44352-02	IMPELLER IMPULSOR	1	1	1	1	
19	63D-44341-00	HOUSING, WATER PUMP CAJA BOMBA DE AGUA	1	1	1	1	
20	93101-22M60	OIL SEAL SELLO ACEITE	2	2	2	2	
21	66T-45344-01	COVER, OIL SEAL CUBIERTA SELLO ACEITE	1	1	1	1	
22	93210-48MG8	O-RING ANILLO O	1	1	1	1	
23	90201-27M00	WASHER, PLATE ARANDELA PLANA	1	1	1	1	

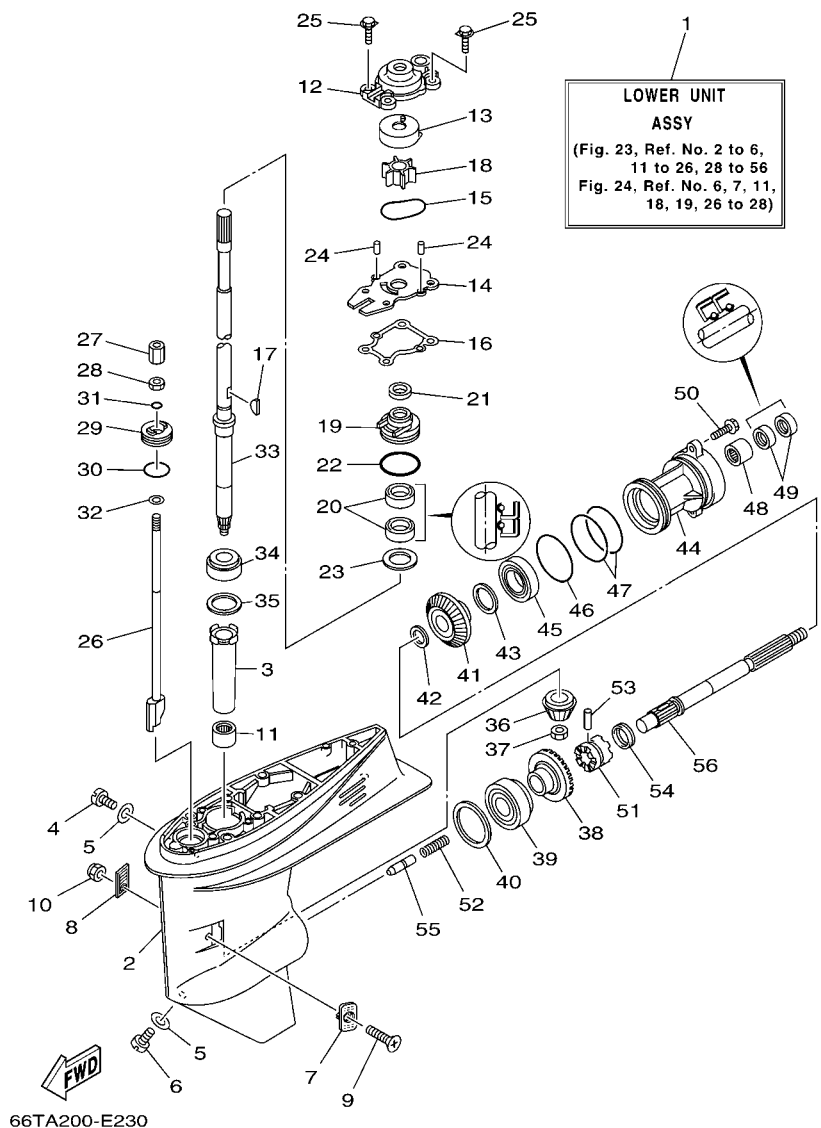

66TA200-E230

FIG. 23 LOWER CASING & DRIVE 1 IMPULSOR E INFERIOR 1

REF. NO.	PART NO. CODIGO Nº	DESCRIPTION DESCRIPCION	MH	WH	W	WT	REMARKS OBSERVACIONES
24	93604-08062	PIN, DOWEL PASADOR DE CLAVIJA	2	2	2	2	
25	90119-08M15	BOLT, WITH WASHER TORNILLO CON ARANDELA	4	4	4	4	
26	66T-44150-01	SHIFT CAM ASSY CONJUNTO EJE LEVA COMPL.	1		1		S(16.7") S(16.7")
	66T-44150-11	SHIFT CAM ASSY CONJUNTO EJE LEVA COMPL.	1	1	1	1	L(21.7") L(21.7")
	66T-44150-21	SHIFT CAM ASSY CONJUNTO EJE LEVA COMPL.	1				X(25.6") X(25.6")
27	61N-44146-00	CONNECTOR, SHIFT ROD CONECTOR VARILLA DE CAMBIO	1	1	1	1	
28	95380-06700	NUT TUERCA	1	1	1	1	
29	66T-45321-00	PLATE PLACA	1	1	1	1	
30	93210-33MG4	O-RING ANILLO O	1	1	1	1	
31	93210-06ME6	O-RING ANILLO O	1	1	1	1	
32	92990-06600	WASHER, PLATE ARANDELA PLANA	1	1	1	1	
33	66T-45501-01	DRIVE SHAFT COMP. EJE DE MANDO COMPL.	1		1		S(16.7") S(16.7")
	66T-45501-11	DRIVE SHAFT COMP. EJE DE MANDO COMPL.	1	1	1	1	L(21.7") L(21.7")
	66T-45501-21	DRIVE SHAFT COMP. EJE DE MANDO COMPL.	1				X(25.6") X(25.6")
34	93332-00001	BEARING COJINETE	1	1	1	1	
35	663-45587-01	SHIM (T:0.10MM) LAINA (T:0.10MM)	1	1	1	1	UR UR
	663-45587-10	SHIM (T:0.12MM) LAINA (T:0.12MM)	1	1	1	1	UR UR
	663-45587-20	SHIM (T:0.15MM) LAINA (T:0.15MM)	1	1	1	1	UR UR
	663-45587-30	SHIM (T:0.18MM) LAINA (T:0.18MM)	1	1	1	1	UR UR
	663-45587-40	SHIM (T:0.30MM) LAINA (T:0.30MM)	1	1	1	1	UR UR
	663-45587-50	SHIM (T:0.40MM) LAINA (T:0.40MM)	1	1	1	1	UR UR
	663-45587-60	SHIM (T:0.50MM) LAINA (T:0.50MM)	1	1	1	1	UR UR
36	66T-45551-00	PINION (13T) PINON (13T)	1	1	1	1	
37	90170-12138	NUT TUERCA	1	1	1	1	
38	66T-45560-01	GEAR 1 (26T) ENGRANAJE 1 (26T)	1	1	1	1	
39	93332-00003	BEARING COJINETE	1	1	1	1	
40	663-45567-01	SHIM (T:0.10MM) LAINA (T:0.10MM)	1	1	1	1	UR UR

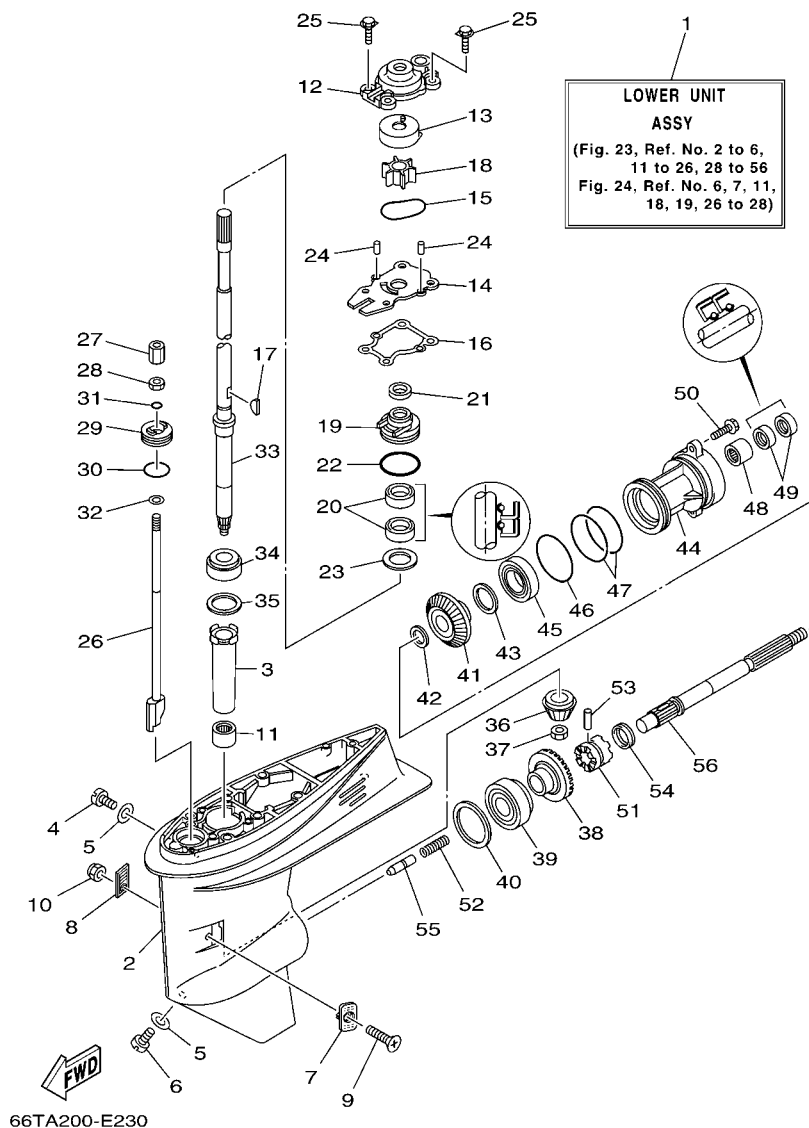

66TA200-E230

FIG. 23 LOWER CASING & DRIVE 1 IMPULSOR E INFERIOR 1

REF. NO.	PART NO. CODIGO Nº	DESCRIPTION DESCRIPCION	MH	WH	W	WT	REMARKS OBSERVACIONES
40	663-45567-10	SHIM (T:0.12MM) LAINA (T:0.12MM)	1	1	1	1	UR UR
	663-45567-20	SHIM (T:0.15MM) LAINA (T:0.15MM)	1	1	1	1	UR UR
	663-45567-30	SHIM (T:0.18MM) LAINA (T:0.18MM)	1	1	1	1	UR UR
	663-45567-40	SHIM (T:0.30MM) LAINA (T:0.30MM)	1	1	1	1	UR UR
	663-45567-50	SHIM (T:0.40MM) LAINA (T:0.40MM)	1	1	1	1	UR UR
	663-45567-60	SHIM (T:0.50MM) LAINA (T:0.50MM)	1	1	1	1	UR UR
41	66T-45571-00	GEAR 2 (26T) ENGRANAJE 2 (26T)	1	1	1	1	
42	90201-22429	WASHER, PLATE ARANDELA PLANA	1	1	1	1	
43	63D-45577-00	SHIM (T:0.10MM) LAINA (T:0.10MM)	1	1	1	1	UR UR
	63D-45577-10	SHIM (T:0.12MM) LAINA (T:0.12MM)	1	1	1	1	UR UR
	63D-45577-20	SHIM (T:0.15MM) LAINA (T:0.15MM)	1	1	1	1	UR UR
	63D-45577-30	SHIM (T:0.18MM) LAINA (T:0.18MM)	1	1	1	1	UR UR
	63D-45577-40	SHIM (T:0.30MM) LAINA (T:0.30MM)	1	1	1	1	UR UR
	63D-45577-50	SHIM (T:0.40MM) LAINA (T:0.40MM)	1	1	1	1	UR UR
	63D-45577-60	SHIM (T:0.50MM) LAINA (T:0.50MM)	1	1	1	1	UR UR
44	63D-45361-02-4D	CAP, LOWER CASING FUNDA INFERIOR	1	1	1	1	
45	93306-001U1	BEARING COJINETE	1	1	1	1	
46	93210-69MG6	O-RING ANILLO O	1	1	1	1	
47	93210-74MG5	O-RING ANILLO O	2	2	2	2	
48	93317-22204	BEARING COJINETE	1	1	1	1	
49	93101-22M00	OIL SEAL SELLO ACEITE	2	2	2	2	
50	90105-08M61	BOLT, FLANGE TORNILLO	2	2	2	2	
51	66T-45631-00	CLUTCH, DOG EMBRAGUE DE GARRA	1	1	1	1	
52	90501-15M01	SPRING, COMPRESSION RESORTE DE COMPRESION	1	1	1	1	
53	90250-06023	PIN, STRAIGHT PASADOR CILINDRICO	1	1	1	1	
54	663-45633-00	RING, CROSS PIN ANILLO DE PASADOR	1	1	1	1	
55	66T-45635-00	PLUNGER, SHIFT EMBOLO DE CAMBIO	1	1	1	1	

FIG. 24 LOWER CASING & DRIVE 2

IMPULSOR E INFERIOR 2

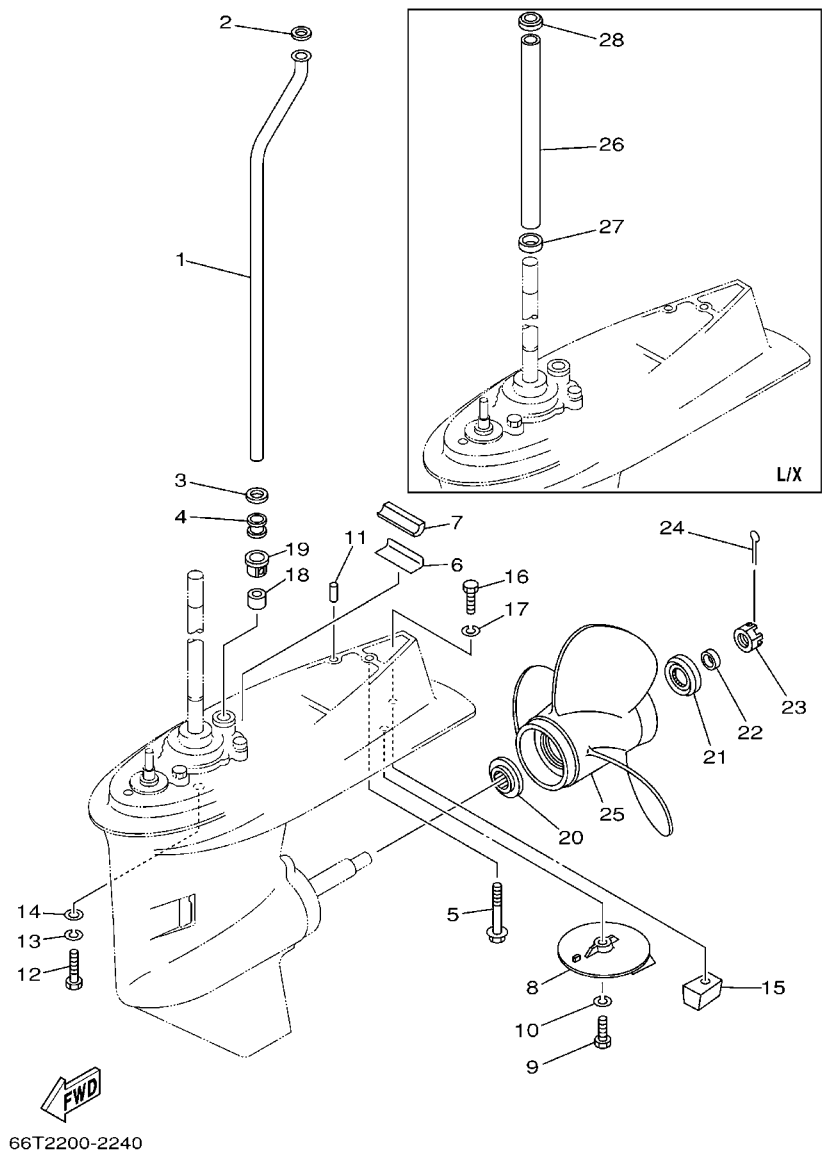

REF. NO.	PART NO. CODIGO Nº	DESCRIPTION DESCRIPCION	MH	WH	W	WT	REMARKS OBSERVACIONES
1	66T-44361-00	TUBE, WATER TUBO DE AGUA	1		1		S(16.7") S(16.7")
	66T-44361-10	TUBE, WATER TUBO DE AGUA	1	1	1	1	L(21.7") L(21.7")
	66T-44361-20	TUBE, WATER TUBO DE AGUA	1				X(25.6") X(25.6")
2	90202-12060	WASHER, PLATE ARANDELA DE PLANA	1	1	1	1	
3	90430-12072	GASKET JUNTA	1	1	1	1	
4	663-44367-00	DAMPER, WATER SEAL GOMA DEL SELLO DE AGUA	1	1	1	1	
5	90119-08M44	BOLT, WITH WASHER TORNILLO CON ARANDELA	1	1	1	1	S(16.7"),L(21.7") S(16.7"),L(21.7")
	90119-08M43	BOLT, WITH WASHER TORNILLO CON ARANDELA	1				X(25.6") X(25.6")
6	663-45376-00-94	GUIDE, SEAL DAMPER GUIA DE SELLO GOMA	1	1	1	1	
7	63D-45375-00	DAMPER, SEAL GOMA DE SELLO	1	1	1	1	
8	664-45371-01	TAB-TRIM QUILLA ESTABILIZADOR	1	1	1	1	
9	97095-08025	BOLT PERNO	1	1	1	1	
10	92995-08100	WASHER ARANDELA	1	1	1	1	
11	93606-12019	PIN, DOWEL PASADOR DE CLAVIJA	2	2	2	2	
12	97075-10040	BOLT PERNO	4	4	4	4	S(16.7"),L(21.7") S(16.7"),L(21.7")
13	92995-10100	WASHER ARANDELA	4	4	4	4	S(16.7"),L(21.7") S(16.7"),L(21.7")
14	92995-10600	WASHER ARANDELA	4	4	4	4	S(16.7"),L(21.7") S(16.7"),L(21.7")
15	67C-45251-00	ANODE CATODE	1	1	1	1	
16	97095-08035	BOLT PERNO	1	1	1	1	
17	92995-08100	WASHER ARANDELA	1	1	1	1	
18	663-44366-00	DAMPER, WATER SEAL GOMA DEL SELLO DE AGUA	1	1	1	1	
19	63D-44312-00	COVER, WATER PUMP HOUSING CUBIERTA CAJA BOMBA DE AGUA	1	1	1	1	
20	663-45987-02	SPACER ESPACIADOR	1	1	1	1	
21	66T-45997-00	SPACER ESPACIADOR	1	1	1	1	
22	90389-22M01	BUSH BUJE	1	1	1	1	
23	90171-16011	NUT, CASTLE TUERCA ENTALLADA	1	1	1	1	
24	91490-30025	PIN, COTTER CHAVETA	1	1	1	1	

FIG. 24 LOWER CASING & DRIVE 2 IMPULSOR E INFERIOR 2

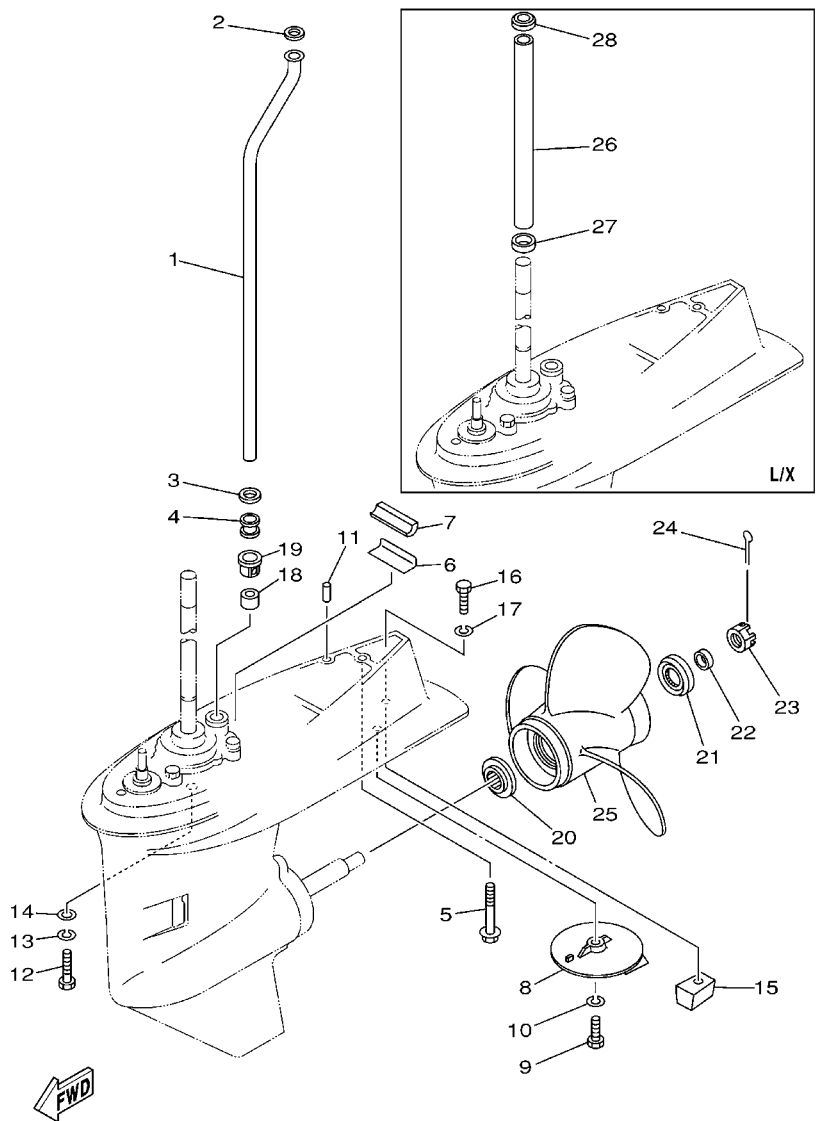

66T2200-2240

REF. NO.	PART NO. CODIGO Nº	DESCRIPTION DESCRIPCION	MH	WH	W	WT	REMARKS OBSERVACIONES
25	69W-45943-00-EL	PROPELLER (3X11"X15"-G) PROPELA (3X11"X15"-G)	1	1	1	1	UR UR
	69W-45945-00-EL	PROPELLER (3X11-1/8"X13"-G) PROPELA (3X11-1/8"X13"-G)	1	1	1	1	UR UR
	69W-45947-00-EL	PROPELLER (3X11-5/8"X11"-G) PROPELA (3X11-5/8"X11"-G)	1	1	1	1	UR UR
	69W-45952-00-EL	PROPELLER (3X11-3/8"X12"-G) PROPELA (3X11-3/8"X12"-G)	1	1	1	1	UR UR
	69W-45958-00-EL	PROPELLER (3X11-1/4"X14"-G) PROPELA (3X11-1/4"X14"-G)	1	1	1	1	UR UR
	63D-45941-00-EL	PROPELLER (3X12-1/4"X8"-G) PROPELA (3X12-1/4"X8"-G)	1	1	1	1	UR UR
	663-45941-01-EL	PROPELLER (3X10-3/4"X17"-G) PROPELA (3X10-3/4"X17"-G)	1	1	1	1	UR UR
	663-45949-01-EL	PROPELLER (3X10-3/4"X16"-G) PROPELA (3X10-3/4"X16"-G)	1	1	1	1	UR UR
	663-45952-02-EL	PROPELLER (3X11-3/8"X12"-G) PROPELA (3X11-3/8"X12"-G)	1	1	1	1	UR UR
	663-45954-01-EL	PROPELLER (3X11-3/4"X10"-G) PROPELA (3X11-3/4"X10"-G)	1	1	1	1	UR UR
	663-45956-01-EL	PROPELLER (3X12-1/4"X9"-G) PROPELA (3X12-1/4"X9"-G)	1	1	1	1	UR UR
	663-45958-01-EL	PROPELLER (3X11-1/4"X14"-G) PROPELA (3X11-1/4"X14"-G)	1	1	1	1	UR UR
	663-45930-00-98	PROPELLER (3X10-1/4"X14"-G) PROPELA (3X10-1/4"X14"-G)	1	1	1	1	UR UR
	663-45976-00-98	PROPELLER (3X10-1/4"X15"-G) PROPELA (3X10-1/4"X15"-G)	1	1	1	1	UR UR
	663-45978-00-98	PROPELLER (3X10-1/4"X16"-G) PROPELA (3X10-1/4"X16"-G)	1	1	1	1	UR UR
	663-45970-60-98	PROPELLER (3X11-3/4"X12"-G) PROPELA (3X11-3/4"X12"-G)	1	1	1	1	UR UR
	663-45972-60-98	PROPELLER (3X12"X11"-G) PROPELA (3X12"X11"-G)	1	1	1	1	UR UR
	663-45974-60-98	PROPELLER (3X11-1/2"X13"-G) PROPELA (3X11-1/2"X13"-G)	1	1	1	1	UR UR
26	66T-44362-10	TUBE, WATER TUBO DE AGUA	1	1	1	1	L(21.7") L(21.7")
	66T-44362-20	TUBE, WATER TUBO DE AGUA	1				X(25.6") X(25.6")
27	90480-25M70	GROMMET TAPON	1	1	1	1	L(21.7"),X(25.6") L(21.7"),X(25.6")
28	90480-30M71	GROMMET TAPON	1	1	1	1	L(21.7"),X(25.6") L(21.7"),X(25.6")

FIG. 26 STEERING GUIDE

DIRECCIONGUIAR

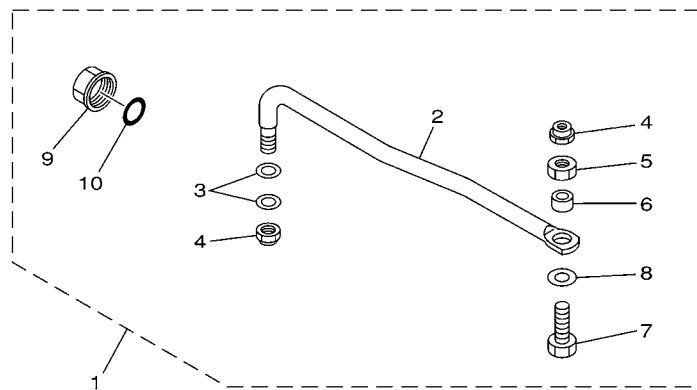

65W0010-8210

REF. NO.	PART NO. CODIGO Nº	DESCRIPTION DESCRIPCION	MH	WH	W	WT	REMARKS OBSERVACIONES
1	65W-61350-00	STEERING GUIDE ATTACHMENT KIT ESTUCHE ADITAMENTO GUIA DE TIM			1	1	AP CAR,CHN,ARG,RUS AP CAR,CHN,ARG,RUS
2	65W-61351-00	.ROD, STEERING LINK .VARILLA ESLABON DIRECCION			1	1	
3	90201-10M20	.WASHER, PLATE .ARANDELA PLANA			2	2	
4	90185-09M01	.NUT, SELF-LOCKING .TUERCA AUTOBLOCANTE			2	2	
5	90170-09M03	.NUT .TUERCA			1	1	
6	90387-10M42	.COLLAR .ESPACIADOR			1	1	
7	90101-09M01	.BOLT .TORNILLO			1	1	
8	90201-10M63	.WASHER, PLATE .ARANDELA PLANA			1	1	
9	6E5-43145-01	.CAP, CLAMP BRACKET .TAPA			1	1	
10	93210-16275	.O-RING .ANILLO O			1	1	

FIG. 28 REMOTE CONTROL ASSY 1 CONTROL REMOTO COMPL 1

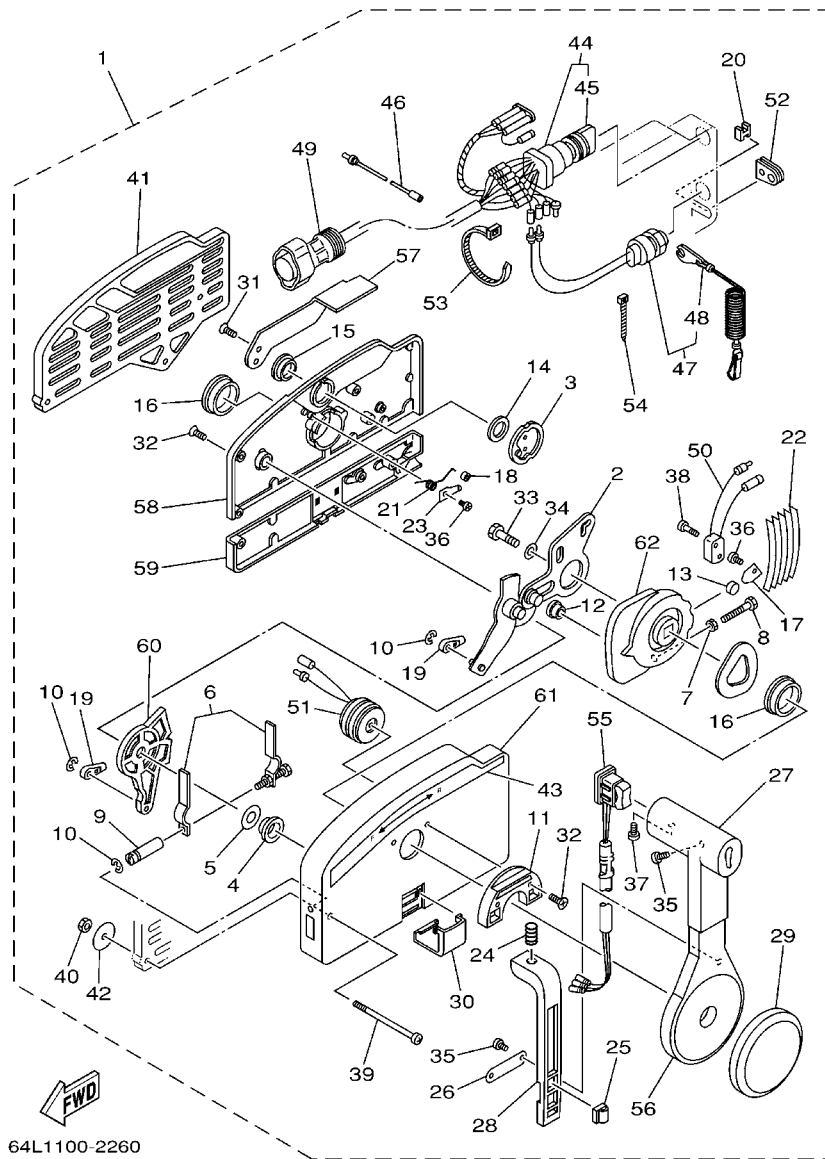

64L1100-2260

REF. NO.	PART NO. CODIGO N°	DESCRIPTION DESCRIPCION	MH	WH	W	WT	REMARKS OBSERVACIONES
1	703-48205-17	REMOTE CONTROL ASSY (10P) REMOTO CONTROL COMPL. (10P)				1	AP WITH PT/T SW. AP WITH PT/T SW.
	703-48203-15	REMOTE CONTROL ASSY (7P) REMOTO CONTROL COMPL. (7P)			1		AP AP
2	703-48261-01	.ARM, THROTTLE .BRAZO ACELERADOR			1	1	
3	703-48153-00	.SHAFT, FREE ACCEL. .EJE			1	1	
4	703-48235-00	.BUSHING .BUJE			1	1	
5	703-48268-00	.SPACER .ESPACIADOR 3			1	1	
6	703-48264-00	.FRICTION, THROTTLE .FRICCION DE ACELERADOR			1	1	
7	95380-05600	.NUT .TUERCA			1	1	
8	97380-05025	.BOLT .TORNILLO HEXAGONAL			1	1	
9	703-48265-00	.SHAFT, FRICTION .EJE FRICCION			1	1	
10	93430-06024	.CIRCLIP .SEGURO			3	3	
11	703-48245-00	.PLATE, LOCK .PLACA CERRADURA			1	1	
12	703-48252-00	.ROLLER, CAM .RODILLO LEVA			1	1	
13	701-48248-00	.ROLLER, FREE ACCEL. .RODILLO ACELERADOR LIBRE			1	1	
14	703-48198-00	.WASHER, WAVE .RONDANA ONDULADA 3			1	1	
15	703-48243-00	.BUSHING .BUJE 3			1	1	
16	703-48236-00	.BUSHING 1 .BUJE			2	2	
17	703-48189-00	.RETAINER .RETENEDOR			1	1	
18	703-48234-00	.ROLLER, DETENT .RODILLO			1	1	
19	703-48345-01	.CABLE END, REMOTE CONTROL 2 .TERMINAL CABLE DE CONTROL REM			2	2	
20	703-48358-00	.ANCHOR, CABLE .ABRAZADERA CABLE			1	1	
21	703-48244-00	.SPRING, FREE ACCEL. .RESORTE ACELERADOR LIBRE			1	1	
22	703-48238-00	.SPRING, DETENT .RESORTE			5	5	
23	703-48246-00	.SPACER .ESPACIADOR			1	1	
24	703-48227-00	.SPRING, NEUTRAL LOCK .RESORTE DE SEGURO			1	1	
25	703-82594-00	.CLAMP .GRAMPA				1	WITH PT/T SW. WITH PT/T SW.
26	703-48226-00	.PLATE, STOPPER .PLACA RETEN			1	1	

FIG. 28 REMOTE CONTROL ASSY 1 CONTROL REMOTO COMPL 1

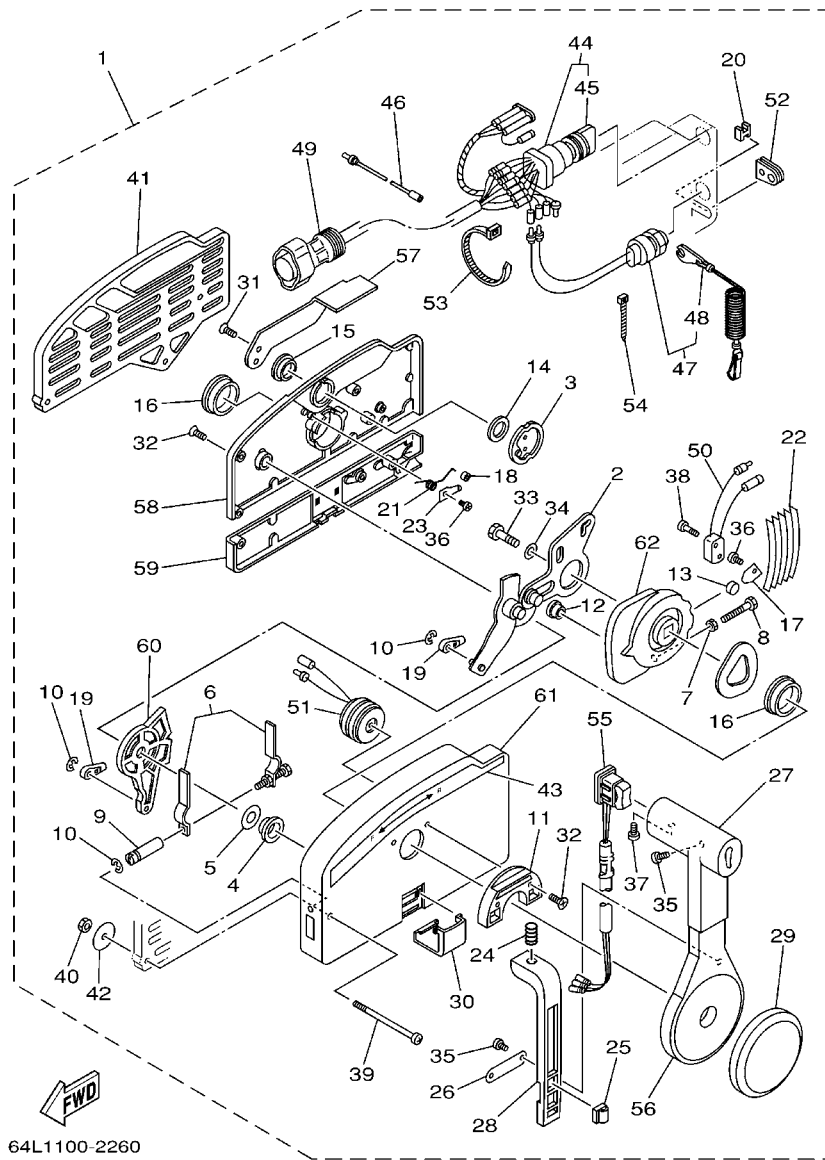

64L1100-2260

REF. NO.	PART NO. CODIGO Nº	DESCRIPTION DESCRIPCION	MH	WH	W	WT	REMARKS OBSERVACIONES
27	703-48222-00	.GRIP, CONTROL LEVER .MANGO DE PALANCA CONTROL			1	1	SINGLE SINGLE
28	703-48223-00	.LOCK, NEUTRAL .CERRADURA NEUTRO			1	1	
29	703-48225-00	.COVER .CUBIERTA			1	1	
30	703-48219-00	.COVER, LEAD .CUBIERTA			1	1	
31	703-48281-00	.SCREW .TORNILLO 1			2	2	
32	703-48282-00	.SCREW .TORNILLO 2			7	7	
33	97380-08030	.BOLT .TORNILLO HEXAGONAL			1	1	
34	92990-08600	.WASHER, PLATE .ARANDELA PLANA			1	1	
35	98580-04010	.SCREW, PAN HEAD .TORNILLO DE CABEZA CRUZADA			3	3	
36	98580-04006	.SCREW, PAN HEAD .TORNILLO DE CABEZA CRUZADA			2	2	
37	98580-05010	.SCREW, PAN HEAD .TORNILLO DE CABEZA CRUZADA			1	1	
38	98580-03015	.SCREW, PAN HEAD .TORNILLO DE CABEZA CRUZADA			2	2	
39	703-48291-10	.SCREW (M6) .TORNILLO (M6)			3	3	
40	95380-06600	.NUT, HEXAGON .TUERCA			3	3	
41	703-48293-10	.SPACER, REMOTE CONTROL .ESPACIADOR			1	1	SINGLE SINGLE
42	701-48287-00	.WASHER .ARANDELA			3	3	
43	703-48215-00	.GRAPHIC .CALCOMANIA 1			1	1	
44	703-82510-43	.MAIN SWITCH ASSY .CONJUNTO DE LLAVE IGNICION			1	1	FOR 703-48205-17 FOR 703-48205-17
	703-82510-33	.MAIN SWITCH ASSY .CONJUNTO DE LLAVE IGNICION			1	1	FOR 703-48203-15 FOR 703-48203-15
45	703-82577-00	.CAP, KEY .TAPA			1	1	
46	703-82531-00	.WIRE, LEAD (L70) .CABLE CONDUCTOR (L70)			1	1	
47	688-82575-01	.ENGINE STOP SWITCH ASSY .INTERRUPTOR DE PARADA COMPL			1	1	
48	682-82556-00	.LANYARD, STOP SWITCH .RETENER			1	1	
49	688-8258A-20	.EXTENSION, WIRE HARNESS (4.9M) .EXTENSION, ARNES DE CABLES (4			1	1	(10P) (10P)
	688-82586-21	.EXTENSION, WIRE HARNESS (4.9M) .EXTENSION, ARNES DE CABLES (4			1	1	(7P) (7P)
50	703-82540-00	.NEUTRAL SWITCH ASSY .INTERRUPTOR NEUTRAL COMPL			1	1	
51	703-83383-02	.BUZZER .ZUMBADOR			1	1	

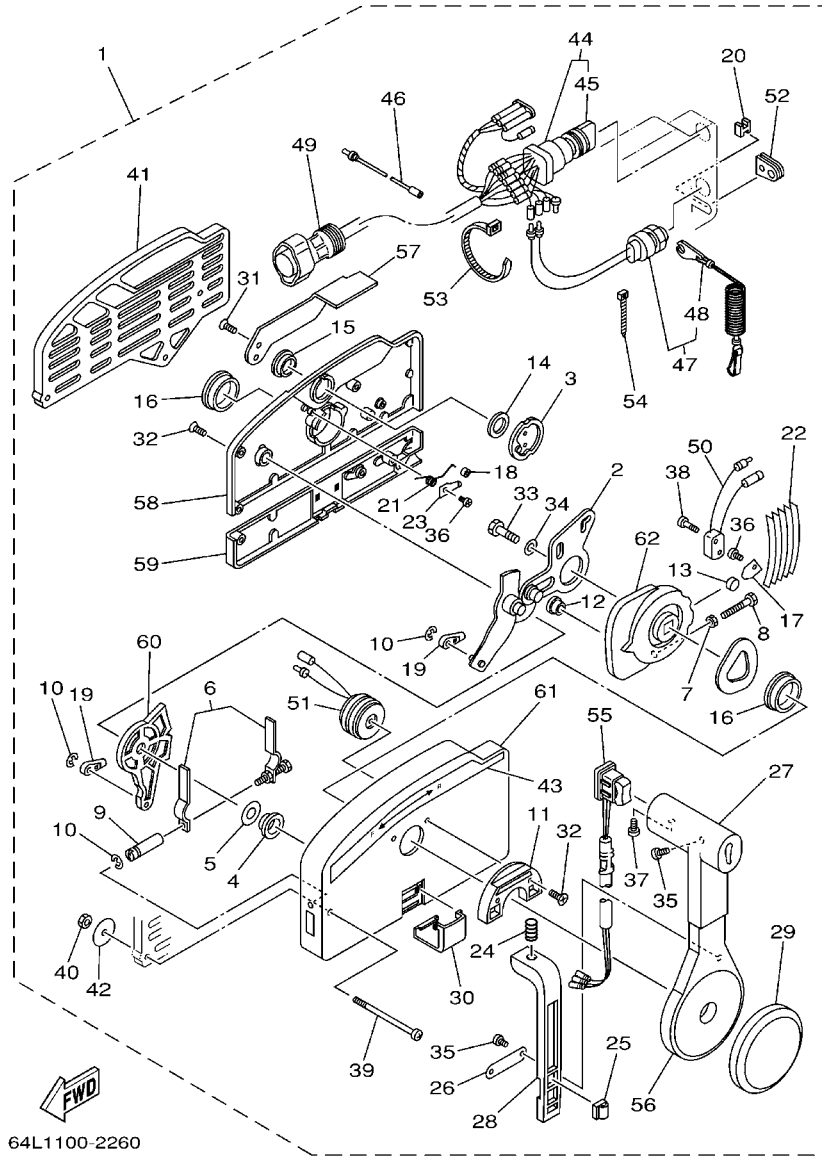

64L1100-2260

FIG. 28 REMOTE CONTROL ASSY 1 CONTROL REMOTO COMPL 1

REF. NO.	PART NO. CODIGO Nº	DESCRIPTION DESCRIPCION	MH	WH	W	WT	REMARKS OBSERVACIONES
52	703-48284-00	.GROMMET .TAPON 1				1 1	
53	703-82591-00	.BAND .BANDA				1 1	
54	703-82592-00	.BAND .BANDA				1 1	
55	703-82563-02	.TRIM & TILT SWITCH ASSY .INTERRUPTOR DE INCLINACION				1	WITH PT/T SW. WITH PT/T SW.
	703-48224-00	.COVER, CONTROL LEVER .CUBIERTA DE PALANCA CONTROL				1	WITHOUT PT/T SW. WITHOUT PT/T SW.
56	703-48221-00	.LEVER, CONTROL .PALANCA CONTROL				1 1	
57	703-48152-00	.KNOB, FREE ACCEL. .PERILLA				1 1	
58	703-48212-00	.BACK PLATE 1 .PLACA TRASERA 1				1 1	
59	703-48213-00	.BACK PLATE 2 .PLACA TRASERA 2				1 1	
60	703-48271-00	.ARM, SHIFT .BRAZO CAMBIADOR				1 1	
61	703-48211-01	.HOUSING,1 .CAJA				1 1	
62	703-48232-00	.GEAR .ENGRANAJE 1				1 1	

FIG. 29 REMOTE CONTROL ASSY 2 CONTROL REMOTO COMPL 2

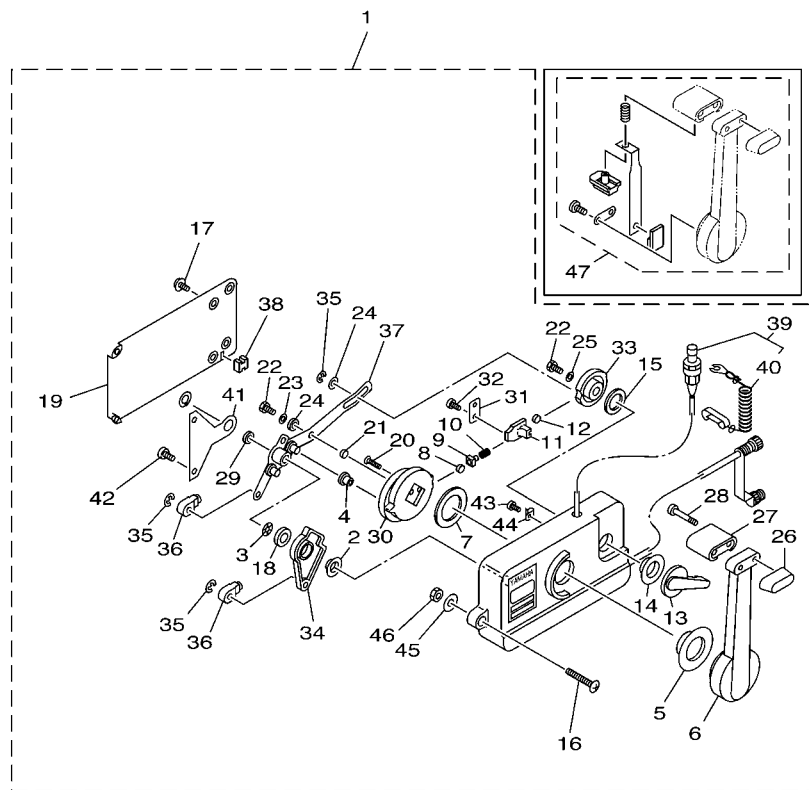

66T4200-3290

REF. NO.	PART NO. CODIGO Nº	DESCRIPTION DESCRIPCION	MH	WH	W	WT	REMARKS OBSERVACIONES
1	701-48140-E0	REMOTE CONTROL ASSY (LEFT) REMOTO CONTROL COMPL (ZURDO)			1		AP FOR RUS AP FOR RUS
2	701-48235-00	.BUSHING .BUJE			1		
3	701-48197-10	.WASHER, WAVE .RONDANA ONDULADA 2			1		
4	701-48252-00	.ROLLER, CAM .RODILLO LEVA			1		
5	701-48234-00	.BUSHING 1 .BUJE			1		
6	701-48221-00	.LEVER, CONTROL .PALANCA CONTROL			1		
7	701-48196-11	.WASHER, WAVE .ARANDELA ONDULADA			1		
8	701-48236-00	.ROLLER, DETENT .RODILLO			1		
9	702-48237-00	.ADAPTOR .ADAPTADOR			1		
10	702-48238-00	.SPRING, DETENT .RESORTE			1		
11	701-48249-00	.ADAPTOR, SPRING .RESORTE ADAPTADOR			1		
12	701-48248-00	.ROLLER, FREE ACCEL. .RODILLO ACELERADOR LIBRE			1		
13	701-48152-20	.KNOB, FREE ACCEL. .PERILLA			1		LEFT LEFT
14	701-48243-00	.BUSHING .BUJE 3			1		
15	701-48198-10	.WASHER, WAVE .RONDANA ONDULADA 3			1		
16	701-48281-10	.SCREW .TORNILLO 1			3		
17	701-48289-00	.SCREW .TORNILLO 4			4		
18	701-48268-00	.SPACER .ESPACIADOR 3			1		
19	701-48213-00	.BACK PLATE 2 .PLACA TRASERA 2			1		
20	92780-06025	.SCREW, FLAT HEAD .TORNILLO CABEZA PLANA			2		
21	701-48255-00	.COLLAR .COLLAR 1			1		
22	97390-06018	.BOLT .TORNILLO			2		
23	702-48288-00	.WASHER, PLAIN .ARANDELA			1		
24	701-48246-00	.SPACER .ESPACIADOR			2		
25	92990-06300	.WASHER, INTERNAL TOOTH .ARANDELA PLANA			1		
26	701-48229-00	.GRIP, CONTROL LEVER .MANGO DE PALANCA CONTROL 2			1		
27	701-48222-00	.GRIP, CONTROL LEVER .MANGO DE PALANCA CONTROL			1		

B7

FIG. 29 REMOTE CONTROL ASSY 2 CONTROL REMOTO COMPL 2

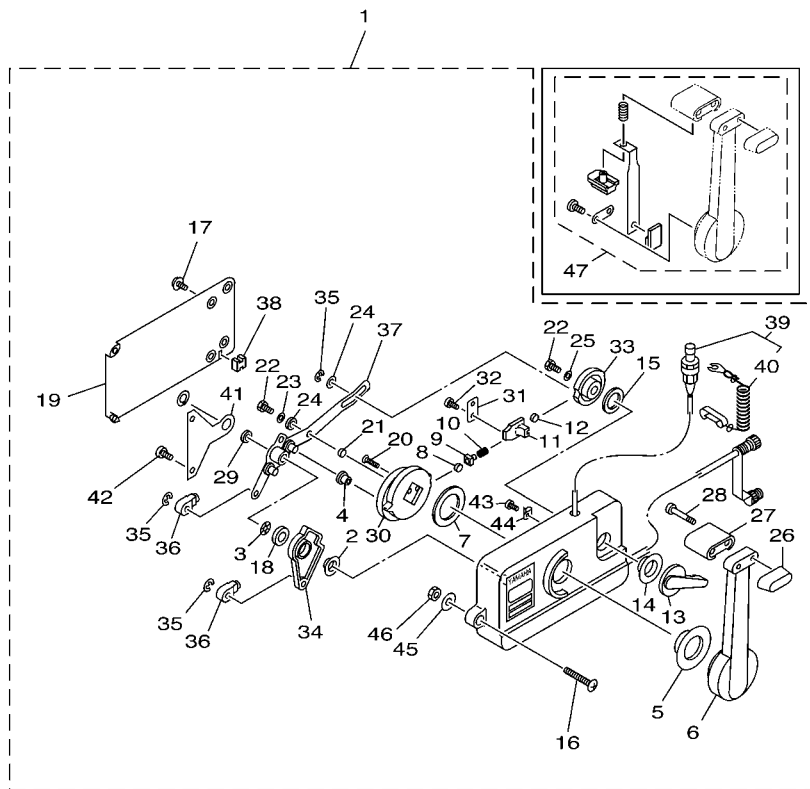

REF. NO.	PART NO. CODIGO Nº	DESCRIPTION DESCRIPCION	MH	WH	W	WT	REMARKS OBSERVACIONES
28	701-48282-00	.SCREW .TORNILLO 2				2	
29	701-48266-00	.SPACER .ESPACIADOR 2				1	
30	701-48232-00	.GEAR .ENGRANAJE 1				1	
31	701-48189-11	.RETAINER .RETENEDOR				1	
32	98580-05010	.SCREW, PAN HEAD .TORNILLO DE CABEZA CRUZADA				2	
33	701-48153-12	.SHAFT, FREE ACCEL. .EJE				1	
34	701-48271-10	.ARM, SHIFT .BRAZO CAMBIADOR				1	LEFT LEFT
35	93430-06024	.CIRCLIP .SEGURO				3	
36	703-48345-01	.CABLE END, REMOTE CONTROL 2 .TERMINAL CABLE DE CONTROL REM				2	
37	701-48261-20	.ARM, THROTTLE .BRAZO ACELERADOR				1	
38	701-48358-00	.ANCHOR, CABLE .ABRAZADERA CABLE				1	
39	701-82575-53	.ENGINE STOP SWITCH ASSY .INTERRUPTOR DE PARADA COMPL				1	
40	682-82556-00	.LANYARD, STOP SWITCH .RETENER				1	
41	701-48133-00	.PLATE, LINK .PLACA DE ESLABON				1	
42	98580-05020	.SCREW, PAN HEAD .TORNILLO DE CABEZA CRUZADA				2	
43	701-48283-00	.SCREW .TORNILLO 3				1	
44	701-82594-00	.CLAMP .GRAMPA				1	
45	701-48287-00	.WASHER .ARANDELA				3	
46	95380-06600	.NUT, HEXAGON .TUERCA				3	
47	701-48280-00	NEUTRAL LOCK KIT REMOTO CONTROL COMPL.				1	



66T4200-3290

FIG. 30 SWITCH & PANEL

PANEL DE INTERRUPTOR

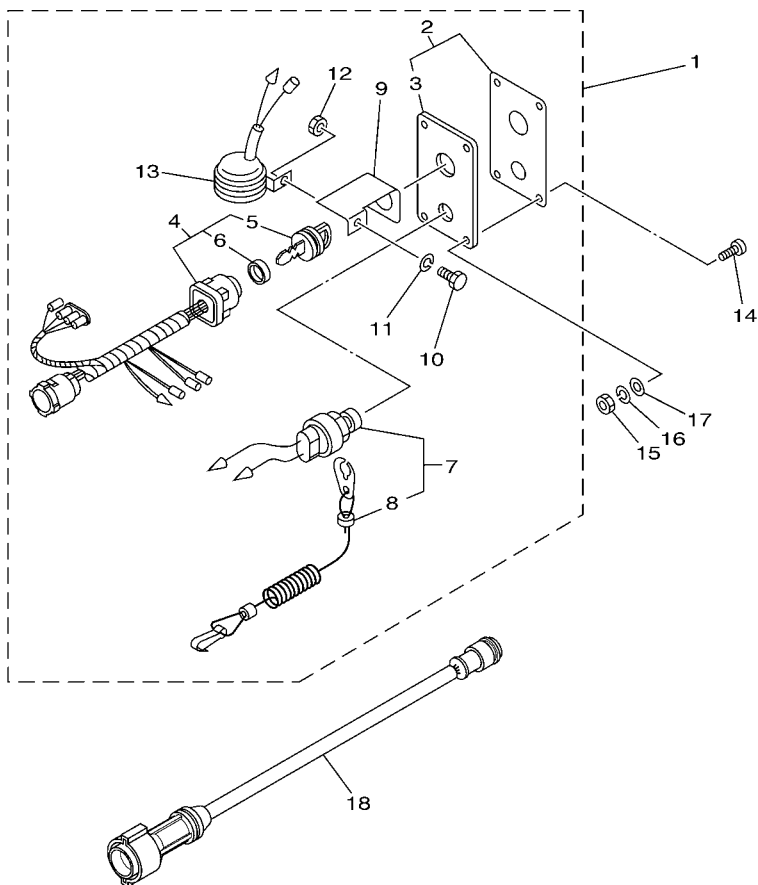

REF. NO.	PART NO. CODIGO Nº	DESCRIPTION DESCRIPCION	MH	WH	W	WT	REMARKS OBSERVACIONES
1	704-82570-08	PANEL SWITCH ASSY INTERRUPTOR DE PANEL COMPL.			1		AP FOR RUS AP FOR RUS
2	704-82571-02	.PANEL, SWITCH .PANEL DE INTERRUPTOR			1		
3	6R5-82588-01	..PLATE ..PLACA			1		
4	704-82510-07	.MAIN SWITCH ASSY .CONJUNTO DE LLAVE IGNICION			1		
5	703-82577-00	..CAP, KEY ..TAPA			1		
6	6K1-82532-00	..CAP ..TAPA			1		
7	688-82575-01	.ENGINE STOP SWITCH ASSY .INTERRUPTOR DE PARADA COMPL			1		
8	682-82556-00	..LANYARD, STOP SWITCH ..RETENER			1		
9	64D-82581-00	.STAY, CORD CLAMP .SOPORTE DE GRAMPA DE CABLE			1		
10	97303-05012	.BOLT ..TORNILLO			1		
11	92903-05100	.WASHER, SPRING ..RONDANA SENCILLA			1		
12	95303-05700	.NUT ..TUERCA			1		
13	688-83383-11	.BUZZER ..ZUMBADOR			1		
14	90149-05M05	SCREW TORNILLO DE REGLAJE			4		AP FOR RUS AP FOR RUS
15	95380-05600	NUT TUERCA			4		AP FOR RUS AP FOR RUS
16	92990-05100	WASHER, SPRING ARANDELA PLANA			4		AP FOR RUS AP FOR RUS
17	92990-05600	WASHER, PLATE ARANDELA PLANA			4		AP FOR RUS AP FOR RUS
18	688-82586-50	EXTENSION, WIRE HARNESS (5M) EXTENSION, CONJ. DE CABLES (5M)			1		AP FOR RUS (7P) AP FOR RUS (7P)



66T6200-C300

FIG. 31 OPTIONAL PARTS

PARTES OPCIONALES

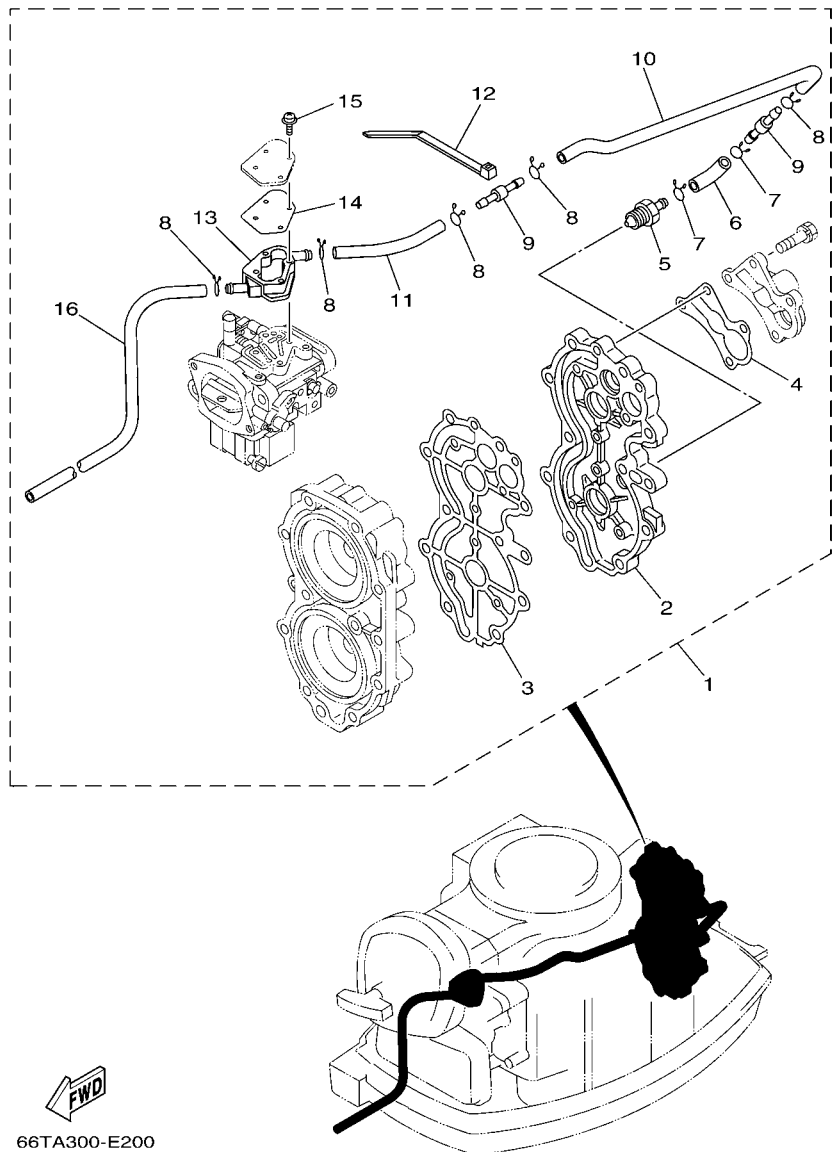



66TA300-E200

REF. NO.	PART NO. CODIGO Nº	DESCRIPTION DESCRIPCION	MH	WH	W	WT	REMARKS OBSERVACIONES
1	66T-12440-51	HEAT EXCHANGER ASSY INTERCAMBIADOR DE CALOR COMPL	1	1	1	1	AP AP
2	66T-11191-50	.COVER, CYLINDER HEAD 1 .TAPA CULATA DE CILINDRO 1	1	1	1	1	
3	66T-11193-A2	.GASKET, HEAD COVER 1 .EMPAQUE	1	1	1	1	
4	676-12414-A1	.GASKET, COVER .EMPAQUE	1	1	1	1	
5	66T-12469-00	.JOINT 1 .CONDUCTO	1	1	1	1	
6	6E5-24315-00	.PIPE 5 .TUBO DE DESAGUE	1	1	1	1	
7	90467-11M08	.CLIP .PRESILLA	2	2	2	2	
8	90467-10M04	.CLIP .PRESILLA	5	5	5	5	
9	6E5-24379-00	.PIPE, JOINT 4 .TUBO DE UNION 4	2	2	2	2	
10	66T-12481-50	.PIPE 1 .TUBO 1	1	1	1	1	
11	66T-12482-50	.PIPE 2 .TUBO 2	1	1	1	1	
12	90465-13M36	.CLAMP .BRIDA	1	1	1	1	
13	66T-12466-00	.EXCHANGER, HEAT .CAMBIADOR DE CALOR	1	1	1	1	
14	66T-14536-00	.GASKET .EMPAQUE	1	1	1	1	
15	97980-04125	.SCREW, WITH WASHER .TORNILLO, CON ARANDELA	4	4	4	4	
16	90445-11M78	.HOSE (L1000) .TUBO (L1000)	1	1	1	1	

FIG. 32 REPAIR KIT 1

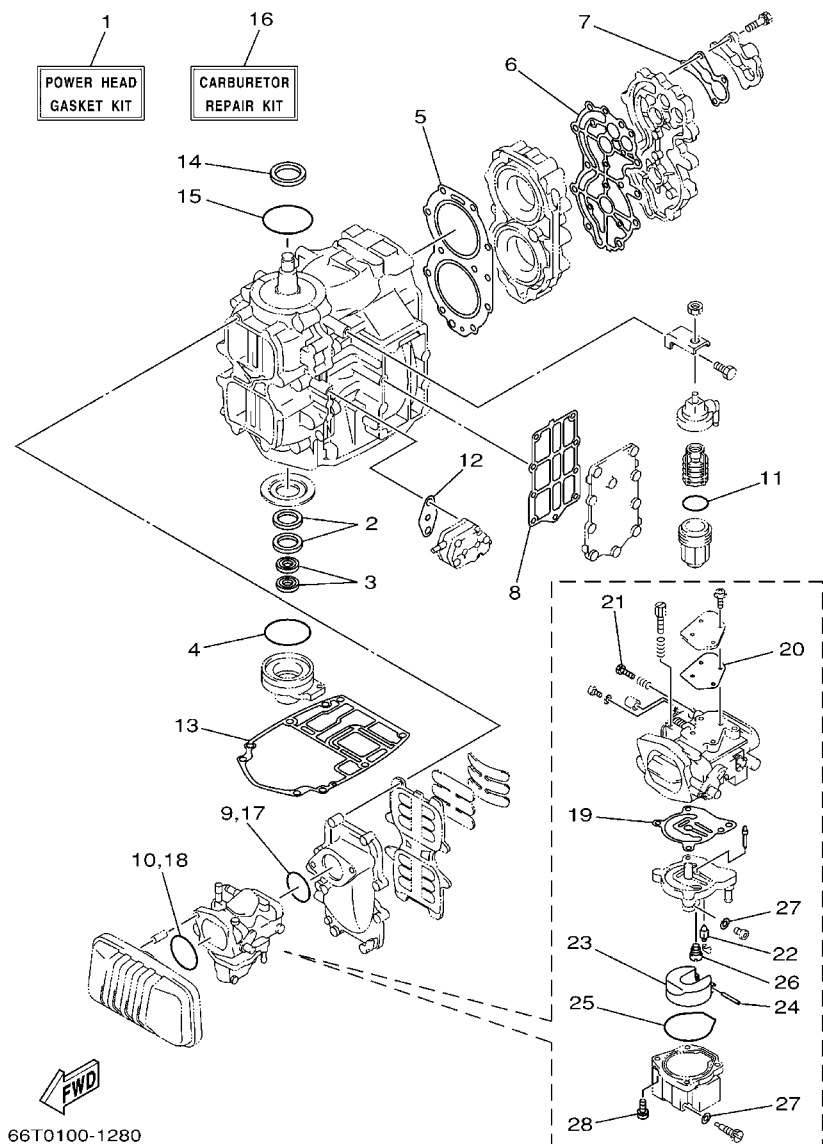
ESTUCHE REPARATION 1



66T0100-1280

C4

REF. NO.	PART NO. CODIGO Nº	DESCRIPTION DESCRIPCION	MH	WH	W	WT	REMARKS OBSERVACIONES
1	66T-W0001-01	POWER HEAD GASKET KIT JUEGO DE EMPAQUE MOTOR	1	1	1	1	
2	93102-30M56	.OIL SEAL .SELLO ACEITE	2	2	2	2	
3	93101-16001	.OIL SEAL .SELLO ACEITE	2	2	2	2	
4	93210-65M50	.O-RING .ANILLO O	1	1	1	1	
5	66T-11181-A2	.GASKET, CYLINDER HEAD 1 JUNTA, DE CULATA 1	1	1	1	1	
6	66T-11193-A2	.GASKET, HEAD COVER 1 .EMPAQUE	1	1	1	1	
7	676-12414-A1	.GASKET, COVER .EMPAQUE	1	1	1	1	
8	66T-41114-A0	.GASKET, EXHAUST OUTER COVER .EMPAQUE	1	1	1	1	
9	93210-46M16	.O-RING .ANILLO O	1	1	1	1	
10	93210-54M54	.O-RING .ANILLO O	1	1	1	1	
11	93210-32738	.O-RING .ANILLO O	1	1	1	1	
12	650-24431-A0	.GASKET, FUEL PUMP 1 .EMPAQUE BOMBA COMBUST 1	1	1	1	1	
13	66T-45113-A0	.GASKET, UPPER CASING .EMPAQUE	1	1	1	1	
14	93102-35008	.OIL SEAL .SELLO ACEITE	1	1	1	1	
15	93210-75M51	.O-RING .ANILLO O	1	1	1	1	
16	66T-W0093-01	CARBURETOR REPAIR KIT KIT REPARACION CARBURADOR	1	1	1	1	
17	93210-46M16	.O-RING .ANILLO O	1	1	1	1	
18	93210-54M54	.O-RING .ANILLO O	1	1	1	1	
19	66T-14384-01	.GASKET, FLOAT CHAMBER .EMPAQUE DE CAMARA DE BOIA	1	1	1	1	
20	66T-14536-00	.GASKET .EMPAQUE	1	1	1	1	
21	6E5-14323-03	.SCREW, AIR ADJUSTING .TORNILLO DE AJUSTE DE AIRE	1	1	1	1	
22	6E5-14546-00	.VALVE, NEEDLE .VALVULA DE AGUJA	1	1	1	1	
23	6E5-14385-02	.FLOAT .BOIA	1	1	1	1	
24	6E5-14386-02	.PIN, FLOAT .PASADOR DE BOIA	1	1	1	1	
25	66T-14984-00	.GASKET, FLOAT CHAMBER .EMPAQUE CAMARA DE BOIA	1	1	1	1	
26	66T-14992-00	.PLUG .TAPON	1	1	1	1	
27	66T-14959-00	.GASKET .EMPAQUE	2	2	2	2	

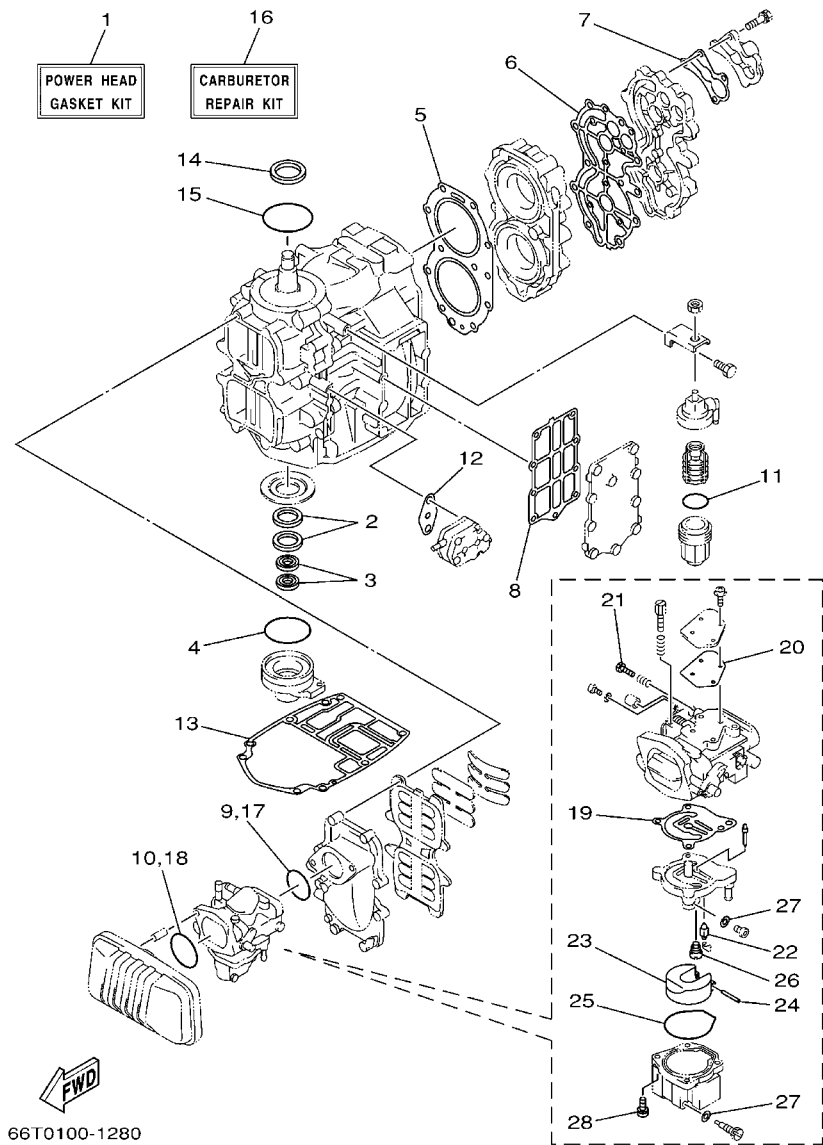

FIG. 32 REPAIR KIT 1

ESTUCHE REPARATION 1

REF. NO.	PART NO. CODIGO Nº	DESCRIPTION DESCRIPCION	MH	WH	W	WT	REMARKS OBSERVACIONES
28	97980-05125	.SCREW, WITH WASHER .TORNILLO, CON ARANDELA	4	4	4	4	

FIG. 33 REPAIR KIT 2

ESTUCHE REPARATION 2

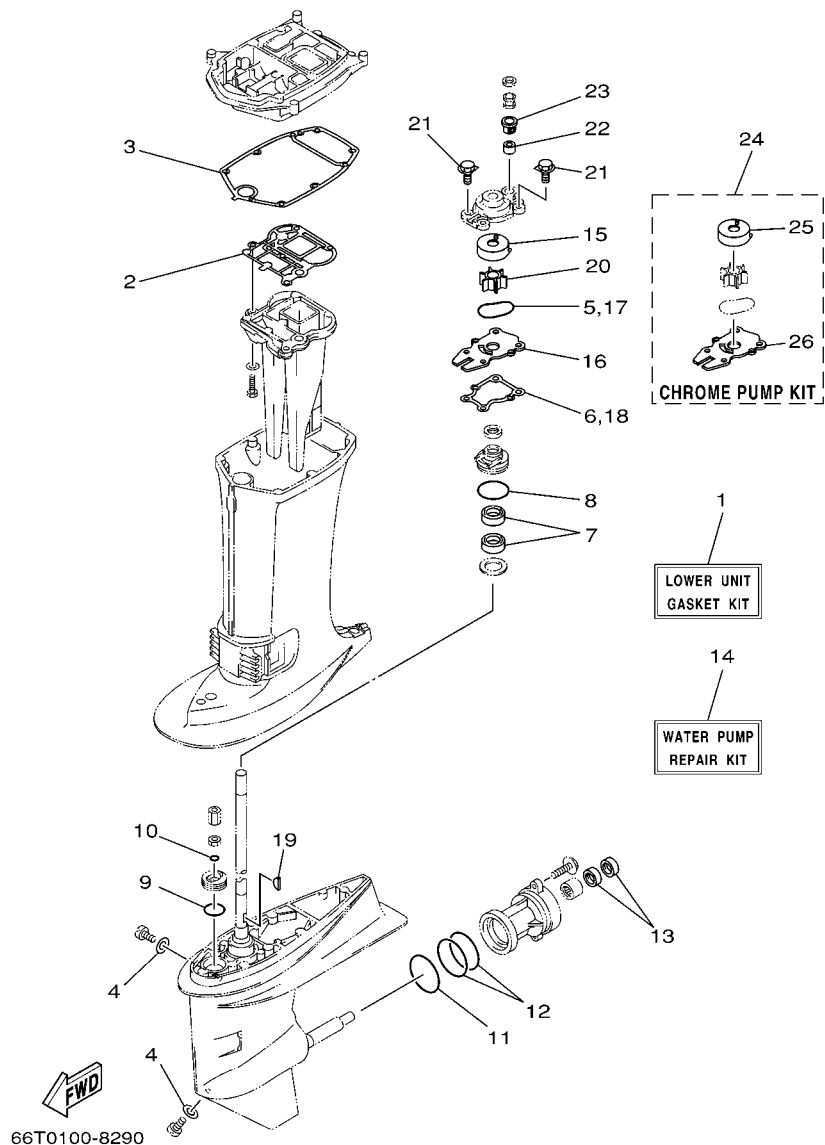

REF. NO.	PART NO. CODIGO Nº	DESCRIPTION DESCRIPCION	MH	WH	W	WT	REMARKS OBSERVACIONES
1	66T-W0001-20	LOWER UNIT GASKET KIT JUEGO DE EMPAQUE UNIDAD INFER	1	1	1	1	
2	66T-41133-A0	.GASKET, EXHAUST MANIFOLD 1 .EMPAQUE ESCAPE MULTIPLE	1	1	1	1	
3	66T-45114-A0	.GASKET, UPPER CASING .EMPAQUE	1	1	1	1	
4	90430-08020	.GASKET .JUNTA	2	2	2	2	
5	93210-59MG7	.O-RING .ANILLO O	1	1	1	1	
6	63D-44316-00	.GASKET, WATER PUMP .EMPAQUE	1	1	1	1	
7	93101-22M60	.OIL SEAL .SELLO ACEITE	2	2	2	2	
8	93210-48MG8	.O-RING .ANILLO O	1	1	1	1	
9	93210-33MG4	.O-RING .ANILLO O	1	1	1	1	
10	93210-06ME6	.O-RING .ANILLO O	1	1	1	1	
11	93210-69MG6	.O-RING .ANILLO O	1	1	1	1	
12	93210-74MG5	.O-RING .ANILLO O	2	2	2	2	
13	93101-22M00	.OIL SEAL .SELLO ACEITE	2	2	2	2	
14	66T-W0078-00	WATER PUMP REPAIR KIT ESTUCHE REPARACION BOMBA AGUA	1	1	1	1	
15	63D-44322-00	.INSERT, CARTRIDGE .CARTUCHO	1	1	1	1	
16	66T-44323-00	.OUTER PLATE, CARTRIDGE .PLACA EXTERIOR DEL CARTUCHO	1	1	1	1	
17	93210-59MG7	.O-RING .ANILLO O	1	1	1	1	
18	63D-44316-00	.GASKET, WATER PUMP .EMPAQUE	1	1	1	1	
19	90280-03M03	.KEY, WOODRUFF .CUNA WOODRUFF	1	1	1	1	
20	6H4-44352-02	.IMPELLER .IMPULSOR	1	1	1	1	
21	90119-08M15	.BOLT, WITH WASHER .TORNILLO CON ARANDELA	4	4	4	4	
22	663-44366-00	.DAMPER, WATER SEAL .GOMA DEL SELLO DE AGUA	1	1	1	1	
23	63D-44312-00	.COVER, WATER PUMP HOUSING .CUBIERTA CAJA BOMBA DE AGUA	1	1	1	1	
24	66T-W0078-0A	CHROME PUMP KIT ESTUCHE REPARACION BOMBA AGUA	1	1	1	1	
25	63D-44322-40	.INSERT, CARTRIDGE .CARTUCHO	1	1	1	1	
26	66T-44323-40	.OUTER PLATE, CARTRIDGE .PLACA EXTERIOR DEL CARTUCHO	1	1	1	1	

NUMERICAL INDEX
INDICE NUMERICO

PART NO. CODIGO N°	REF. NO.	PART NO. CODIGO N°	REF. NO.	PART NO. CODIGO N°	REF. NO.	PART NO. CODIGO N°	REF. NO.	PART NO. CODIGO N°	REF. NO.	PART NO. CODIGO N°	REF. NO.
66T-11111-01-1S	2 - 22	66T-14301-12	5 - 1	66T-15734-00	7 - 14	648-24566-02	6 - 10	65W-42562-00	15 - 6	65W-43192-00	19 - 3
66T-11119-00	2 - 20	66T-14301-40	5 - 1	63V-15741-00	7 - 4	6YJ-24610-01	25 - 2	66T-42610-20-4D	1 - 1	65W-43311-00-4D	18 - 18
66T-11181-A2	2 - 23	66T-14301-50	5 - 1	63V-15744-00	7 - 10	66T-26301-00	14 - 29	66T-42610-K0-4D	1 - 1	65W-43311-10-4D	18 - 18
	32 - 5	6E5-14323-03	5 - 12	6F5-15752-00	7 - 18	65W-26326-00	13 - 19	66T-42613-01	1 - 2		19 - 7
66T-11191-00-1S	2 - 25		32 - 21	6F5-15753-00	7 - 19	65W-26326-10	13 - 19	66T-42615-02	1 - 8	682-43318-01	18 - 38
66T-11191-50	31 - 2	6A0-14325-00	6 - 25	689-15755-01	7 - 21		17 - 10	6E0-42651-02	1 - 4	66T-43350-02	18 - 46
66T-11193-A2	2 - 26	66T-1432A-00	5 - 27	66T-15758-01	7 - 24	6A1-28176-00	13 - 33	6F5-42652-01	1 - 6	65W-43373-00	20 - 2
	31 - 3	6J8-14334-00	5 - 11	66T-15762-01	7 - 28	61H-2819R-31	6 - 32	63D-42677-20	1 - 9	65W-43613-00	18 - 53
	32 - 6	66T-14384-01	5 - 6	66T-15767-00	7 - 8	66T-41113-00-1S	2 - 33	69P-42677-H0	1 - 9	65W-43614-01	18 - 51
676-11325-00	2 - 18		32 - 19	63V-15768-00	7 - 11	66T-41114-A0	2 - 35	63D-42678-11	1 - 10	65W-43615-01	18 - 52
676-11372-00	2 - 34	6E5-14385-02	5 - 18	6F5-15768-00	7 - 20		32 - 8	6J4-42678-H0	1 - 10	65W-43616-00	18 - 50
650-11372-01	4 - 5		32 - 23	66T-15770-00	7 - 15	66T-41131-00-5B	22 - 4	63D-42681-10	1 - 12	66T-43627-00	18 - 26
66T-11400-01	3 - 1	6E5-14386-02	5 - 19	66T-15771-00-94	7 - 36	66T-41131-10-5B	22 - 4	63D-42682-10	1 - 13	65W-43630-02	18 - 39
66T-11412-00	3 - 2		32 - 24	66T-15772-00-94	7 - 39	66T-41133-A0	22 - 5	66T-42710-01-4D	13 - 1	65W-43630-11	18 - 39
66T-11422-00	3 - 3	66T-14440-00	4 - 13	6F5-15779-02	7 - 22		33 - 2	66T-42716-00	13 - 5	66T-43631-01	18 - 48
66T-11432-00	3 - 4	624-14485-00	2 - 5	66T-15784-00	7 - 9	66T-41137-00-5B	22 - 1	66T-42725-00	13 - 8	66T-43631-11	18 - 48
66T-11442-00	3 - 5	66T-14497-00	16 - 10	697-15789-00	7 - 23	66T-41237-00	16 - 5	6G1-42725-00	9 - 21	689-43633-00	15 - 8
6F5-11515-00	3 - 9	66T-14523-00	5 - 10	6F5-15791-00	7 - 17	66T-41252-00	4 - 22	66T-42725-10	13 - 8	65W-43800-02-4D	21 - 1
66T-11565-00	2 - 14	66T-14527-00	5 - 8	66T-15794-00	7 - 13	66T-41256-00	4 - 20	66T-42725-20	13 - 8	6T4-43802-03	21 - 30
66T-11603-00	3 - 16	66T-14536-00	5 - 7	6YJ-24167-00	25 - 7	66T-41257-00	4 - 24	66T-42725-30	17 - 9	65W-43804-00	21 - 3
66T-11604-00	3 - 16		31 - 14	6YJ-24201-00	25 - 1	661-41262-02	4 - 21	65W-42726-00	13 - 23	65W-43805-00	21 - 4
66T-11605-00	3 - 16		32 - 20	6YJ-24201-10	25 - 1	6H4-41271-01	4 - 17	6H4-42726-00	13 - 21	6T4-43808-00	21 - 65
66T-11631-01-93	3 - 15	6E5-14546-00	5 - 16	6YJ-24260-00	25 - 3	66T-41273-00	14 - 41	65W-42726-10	13 - 23	65W-4380F-00	21 - 11
6F5-11633-00	3 - 17		32 - 22	6Y1-24260-12	25 - 3	689-41273-00	4 - 18		17 - 11	65W-4380K-00	21 - 16
663-11634-00	3 - 18	66T-14578-00	5 - 2	6Y1-24268-00	25 - 6	6J8-41274-00	4 - 19	6H1-42726-10	13 - 21	65W-4380L-00	21 - 27
66T-11635-01	3 - 15	66T-14584-00	5 - 3	6G1-24304-02	6 - 1	66T-41611-00	8 - 11	676-42727-00	13 - 20	65W-43810-00	21 - 17
66T-11636-01	3 - 15	6J8-14592-01	5 - 4	6G1-24305-05	25 - 13	66T-41631-01	16 - 4	66T-42738-00-5B	13 - 6	65W-43812-00	21 - 18
6F5-11651-00	3 - 10	61A-1492E-85	5 - 15	6Y1-24305-06	25 - 15	66T-41638-00	16 - 1	66T-42741-00	13 - 26	6H1-43816-00	21 - 25
66T-11681-00	3 - 11	66T-1492F-35	5 - 20	61J-24306-04	25 - 8	6F5-41662-00	16 - 17	664-42791-00	13 - 32	65W-43817-00	21 - 40
6E5-12411-02	2 - 28	66T-14945-02	5 - 14	6E5-24315-00	31 - 6	65W-42101-01-4D	14 - 14	664-42791-10	13 - 32	65W-4381B-00	21 - 22
6E5-12412-00	2 - 29	66T-14959-00	5 - 25	66T-24329-00	13 - 22	664-42119-00	14 - 22	66T-42815-01-4D	13 - 9	6H1-43829-00	21 - 62
676-12413-00-1S	2 - 30		32 - 27	6Y1-24329-00	25 - 5	65W-42121-01-4D	14 - 40	66T-42816-00	13 - 13	65W-4382A-00	21 - 48
676-12414-A1	2 - 31	66T-14981-00	5 - 23	650-24351-01	25 - 12	66T-42123-00	14 - 7	66T-43111-01-4D	18 - 1	65W-43830-00	21 - 37
	31 - 4	66T-14984-00	5 - 21	61J-24360-00	25 - 10	65W-42125-00	14 - 19	65W-43111-10-4D	19 - 1	65W-43831-00	21 - 36
	32 - 7		32 - 25	6E5-24379-00	31 - 9	6G1-42126-00	14 - 18	66T-43112-01-4D	18 - 6	65W-43840-00	21 - 15
66T-12440-51	31 - 1	66T-14991-00	5 - 24	692-24410-00	6 - 15	65W-42131-01	14 - 37	65W-43112-10-4D	19 - 2	62X-43841-00	21 - 34
66T-12466-00	31 - 13	66T-14992-00	5 - 22	663-24411-00	6 - 20	6G1-42137-10	14 - 23	6J8-43113-01	18 - 23	65W-43843-00	21 - 55
66T-12469-00	31 - 5		32 - 26	692-24411-00	6 - 17	65W-42138-00	14 - 16	648-43114-01	18 - 4	65W-43844-00	21 - 49
66T-12481-50	31 - 10	66T-15100-02-1S	2 - 2	6A0-24412-02	6 - 26	65W-42159-00	14 - 17	663-43118-01-4D	18 - 3	6H1-43844-10	21 - 57
66T-12482-50	31 - 11	66T-15396-01-94	2 - 8	6A0-24413-00	6 - 16	66T-42167-00	16 - 2	63D-43131-01	18 - 20	6H1-43845-00	21 - 44
677-13437-0B	1 - 14	66T-15705-00	7 - 7	6A0-24421-01	6 - 24	6F6-42177-A0	14 - 21		19 - 9	6H1-43847-00	21 - 46
6E5-13552-01	2 - 3	66T-15710-00	7 - 1	650-24431-A0	6 - 27	65W-42508-00	15 - 1	66T-43144-00	13 - 14	6H1-4384F-10	21 - 58
	4 - 4	66T-15711-00	7 - 2		32 - 12	65W-42511-00-4D	20 - 6	6E5-43145-01	26 - 9	65W-43851-00	21 - 50
66T-13610-00	4 - 1	66T-15713-00	7 - 5	648-24434-01	6 - 18	65W-42511-10-4D	20 - 6	6G5-43145-01	18 - 25	65W-43853-00	21 - 61
66T-13641-02-1S	4 - 3	66T-15714-00	7 - 3	648-24435-02	6 - 21	65W-42527-00	15 - 3		19 - 13	6T4-43853-00	21 - 38
6E5-14159-00	5 - 17	66T-15716-00	7 - 6	61N-24521-00	6 - 8	648-42528-00	20 - 1	65W-43191-00	18 - 12	65W-43854-00	21 - 47
6E5-14223-00	5 - 13	66T-15723-00	7 - 29	61N-24560-00	6 - 6	65W-42528-00	15 - 10		19 - 4	65W-43855-00	21 - 53
66T-14301-02	5 - 1	66T-15731-00	7 - 16	61N-24563-00	6 - 7	65W-42561-00	15 - 7	65W-43192-00	18 - 11	6H1-43856-10	21 - 56

NUMERICAL INDEX
INDICE NUMERICO

PART NO. CODIGO N°	REF. NO.	PART NO. CODIGO N°	REF. NO.	PART NO. CODIGO N°	REF. NO.	PART NO. CODIGO N°	REF. NO.	PART NO. CODIGO N°	REF. NO.	PART NO. CODIGO N°	REF. NO.
65W-43861-00	21 - 41	66T-44323-40	23 - 14	66T-45501-21	23 - 33	663-45987-02	24 - 20	703-48244-00	28 - 21	65W-61351-00	26 - 2
6H1-43861-10	21 - 20		33 - 26	6H4-45536-00	23 - 3	66T-45997-00	24 - 21	703-48245-00	28 - 11	66T-81303-00	34 - 1
65W-43862-00	21 - 42	63D-44341-00	23 - 19	66T-45551-00	23 - 36	701-48133-00	29 - 41	701-48246-00	29 - 24	66T-81328-00	8 - 13
65W-43865-00	21 - 19	6H4-44352-02	23 - 18	66T-45560-01	23 - 38	701-48140-E0	27 - 2	703-48246-00	28 - 23	66T-81800-02	12 - 1
6H1-43866-00	21 - 31		33 - 20	663-45567-01	23 - 40		29 - 1	701-48248-00	28 - 13	66T-81820-00	12 - 5
6H1-43867-00	21 - 33	66T-44361-00	24 - 1	663-45567-10	23 - 40	703-48152-00	28 - 57		29 - 12	66T-81826-00	12 - 7
65W-43869-00	21 - 5	66T-44361-10	24 - 1	663-45567-20	23 - 40	701-48152-20	29 - 13	701-48249-00	29 - 11	66T-81830-00	12 - 4
65W-4386A-00	21 - 59	66T-44361-20	24 - 1	663-45567-30	23 - 40	703-48153-00	28 - 3	701-48252-00	29 - 4	66T-81840-00	12 - 6
65W-4386K-00	21 - 7	66T-44362-10	24 - 26	663-45567-40	23 - 40	701-48153-12	29 - 33	703-48252-00	28 - 12	66T-81850-01	12 - 3
65W-43871-00	21 - 21	66T-44362-20	24 - 26	663-45567-50	23 - 40	703-48189-00	28 - 17	701-48255-00	29 - 21	66T-81857-00	12 - 2
6H1-43875-00	21 - 43	663-44366-00	24 - 18	663-45567-60	23 - 40	701-48189-11	29 - 31	701-48261-01	28 - 2	689-81870-00	9 - 22
62X-43878-00	21 - 63		33 - 22	66T-45571-00	23 - 41	701-48196-11	29 - 7	701-48261-20	29 - 37	66T-81916-01	9 - 8
65W-43879-00	21 - 12	663-44367-00	24 - 4	63D-45577-00	23 - 43	701-48197-10	29 - 3	703-48264-00	28 - 6	6L2-81945-00	10 - 5
65W-43880-00	21 - 2	6E5-44391-00	13 - 18	63D-45577-10	23 - 43	703-48198-00	28 - 14	703-48265-00	28 - 9	66T-81948-00	11 - 11
65W-43881-00	21 - 6	66T-44514-00-4D	20 - 15	63D-45577-20	23 - 43	701-48198-10	29 - 15	701-48266-00	29 - 29	6G1-8194A-10	10 - 1
65W-43882-00	21 - 8	66T-44514-30-4D	20 - 15	63D-45577-30	23 - 43	703-48198-00	28 - 17	701-48268-00	29 - 18	6G1-81952-00	10 - 4
65W-43887-00	21 - 13	66T-44526-00	20 - 16	63D-45577-40	23 - 43	701-48189-11	29 - 31	703-48268-00	28 - 5	6E5-8195B-01	11 - 2
65W-43888-00	21 - 28	66T-44526-30	20 - 16	63D-45577-50	23 - 43	703-48205-17	27 - 1	703-48271-00	28 - 60	6E5-8195C-01	11 - 5
65W-4388E-00	21 - 14	65W-44551-00-4D	20 - 19	63D-45577-60	23 - 43		28 - 1	701-48271-10	29 - 34	6G1-81970-61	10 - 8
65W-43891-00	21 - 10	65W-44555-10	20 - 20	663-45587-01	23 - 35	703-48211-01	28 - 61	701-48280-00	29 - 47	66T-82105-00	10 - 7
65W-43892-00	21 - 9	66T-44575-00	20 - 21	663-45587-10	23 - 35	703-48212-00	28 - 58	703-48281-00	28 - 31	66T-82115-00	10 - 16
66T-44111-02	14 - 2	66T-45111-00-4D	22 - 8	663-45587-20	23 - 35	701-48213-00	29 - 19	701-48281-10	29 - 16	6E5-82116-00	11 - 10
682-44116-01	16 - 19	66T-45111-10-4D	22 - 8	663-45587-30	23 - 35	703-48213-00	28 - 59	701-48282-00	29 - 28	6E5-82117-01	10 - 6
66T-44121-00	16 - 14	66T-45113-A0	22 - 13	663-45587-40	23 - 35	703-48215-00	28 - 43	703-48282-00	28 - 32	6G5-82119-00	11 - 9
66M-44122-00	16 - 15		32 - 13	663-45587-50	23 - 35	703-48219-00	28 - 30	701-48283-00	29 - 43	66T-82127-00	20 - 26
66T-44124-00	14 - 10	66T-45114-A0	22 - 12	663-45587-60	23 - 35	701-48221-00	29 - 6	703-48284-00	28 - 52	6U0-82127-00	19 - 22
66T-44125-01	16 - 25		33 - 3	66T-45611-00	23 - 56	703-48221-00	28 - 56	701-48287-00	28 - 42	66T-82127-10	20 - 27
	17 - 6	63D-45155-00	22 - 9	66T-45631-00	23 - 51	701-48222-00	29 - 27		29 - 45	6H1-82148-00	19 - 21
66T-44143-00	16 - 21	66T-45211-00-4D	22 - 18	663-45633-00	23 - 54	703-48222-00	28 - 27	702-48288-00	29 - 23	6G1-82151-00	10 - 9
66T-44143-10	16 - 21	63D-45214-00	23 - 7	66T-45635-00	23 - 55	703-48223-00	28 - 28	701-48289-00	29 - 17	6A0-82317-00	9 - 2
61N-44146-00	23 - 27	63D-45215-00	23 - 8	663-45930-00-98	24 - 25	703-48224-00	28 - 55	703-48291-10	28 - 39	66T-82370-00	9 - 16
66T-44150-01	23 - 26	65W-45251-00	19 - 19	63D-45941-00-EL	24 - 25	703-48225-00	28 - 29	703-48293-10	28 - 41	6E3-82370-21	9 - 16
66T-44150-11	23 - 26	676-45251-00	2 - 15	663-45941-01-EL	24 - 25	703-48226-00	28 - 26	701-48320-00	27 - 3	704-82510-07	30 - 4
66T-44150-21	23 - 26	67C-45251-00	24 - 15	69W-45943-00-EL	24 - 25	703-48227-00	28 - 24	701-48320-20	27 - 3	703-82510-33	28 - 44
65W-44173-00	16 - 23	66T-45300-01-4D	23 - 1	69W-45945-00-EL	24 - 25	701-48229-00	29 - 26	701-48320-50	27 - 3	703-82510-43	28 - 44
6E0-44191-11	14 - 13	66T-45300-11-4D	23 - 1	69W-45947-00-EL	24 - 25	701-48232-00	29 - 30	663-48344-00	16 - 27	66T-82519-00	9 - 20
688-44194-00	16 - 9	66T-45300-31-4D	23 - 1	663-45949-01-EL	24 - 25	703-48232-00	28 - 62		17 - 2	703-82531-00	28 - 46
66T-44311-00	23 - 12	66T-45311-01-4D	23 - 2	69W-45952-00-EL	24 - 25	701-48234-00	29 - 5	703-48345-01	28 - 19	6K1-82532-00	30 - 6
63D-44312-00	24 - 19	679-45318-00	22 - 16	663-45952-02-EL	24 - 25	703-48234-00	28 - 18		29 - 36	6F5-82540-00	10 - 27
	33 - 23	66T-45321-00	23 - 29	663-45954-01-EL	24 - 25	701-48235-00	29 - 2	701-48358-00	29 - 38	703-82540-00	28 - 50
63D-44316-00	23 - 16	688-45341-10	23 - 6	663-45956-01-EL	24 - 25	703-48235-00	28 - 4	703-48358-00	28 - 20	66T-82553-00	10 - 28
	33 - 6	66T-45344-01	23 - 21	69W-45958-00-EL	24 - 25	701-48236-00	29 - 8	66T-48501-01	17 - 1	66T-82554-00	10 - 29
63D-44322-00	23 - 13	63D-45361-02-4D	23 - 44	663-45958-01-EL	24 - 25	703-48236-00	28 - 16	65W-48511-00	17 - 7	682-82556-00	14 - 43
	33 - 15	664-45371-01	24 - 8	663-45970-60-98	24 - 25	702-48237-00	29 - 9		20 - 29		28 - 48
63D-44322-40	23 - 13	63D-45375-00	24 - 7	663-45972-60-98	24 - 25	702-48238-00	29 - 10	670-48511-00-4D	20 - 29		29 - 40
	33 - 25	663-45376-00-94	24 - 6	663-45974-60-98	24 - 25	703-48238-00	28 - 22	6H3-48538-00	16 - 29		30 - 8
66T-44323-00	23 - 14	66T-45501-01	23 - 33	663-45976-00-98	24 - 25	701-48243-00	29 - 14		17 - 4	688-82560-10	9 - 19
	33 - 16	66T-45501-11	23 - 33	663-45978-00-98	24 - 25	703-48243-00	28 - 15	65W-61350-00	26 - 1	703-82563-02	28 - 55

NUMERICAL INDEX
INDICE NUMERICO

PART NO. CODIGO N°	REF. NO.	PART NO. CODIGO N°	REF. NO.	PART NO. CODIGO N°	REF. NO.	PART NO. CODIGO N°	REF. NO.	PART NO. CODIGO N°	REF. NO.	PART NO. CODIGO N°	REF. NO.
704-82570-08	30 - 1	682-86117-00	10 - 22	90119-08M15	33 - 21	90201-22429	23 - 42	90386-12MA2	13 - 11	90465-20M31	10 - 31
704-82571-02	30 - 2	66T-87149-00	11 - 8	90119-08M39	12 - 8	90201-22M03	18 - 22	90386-14MA1	19 - 6	90465-25M57	13 - 24
66T-82575-01	14 - 42	66T-W0001-01	32 - 1	90119-08M42	22 - 15		19 - 11	90386-18M44	19 - 27	90467-06016	4 - 10
688-82575-01	28 - 47	66T-W0001-20	33 - 1	90119-08M43	24 - 5	90201-27M00	23 - 23	90386-18MA0	19 - 28	90467-08004	6 - 5
	30 - 7	66T-W0004-00	4 - 2	90119-08M44	24 - 5	90201-43M00	14 - 33	90386-22M15	18 - 21	90467-10M04	31 - 8
701-82575-53	29 - 39	63D-W0070-10	1 - 11	90119-08M51	7 - 33	90202-10M56	15 - 9		19 - 10	90467-11M08	31 - 7
703-82577-00	28 - 45	66T-W0070-H0	1 - 11	90119-08M52	12 - 9	90202-12031	18 - 28	90386-40M99	14 - 36	90468-18008	14 - 12
	30 - 5	66T-W0078-00	33 - 14	90119-08M79	22 - 2	90202-12060	24 - 2	90386-40MA0	14 - 32		16 - 28
6E3-8257H-00	13 - 34	66T-W0078-0A	33 - 24	90119-08MA5	2 - 24	90202-43M57	14 - 35	90386-44M03	20 - 9		17 - 3
689-8257Y-00	14 - 44	66T-W0084-02-4D	14 - 1	90119-10005	2 - 7	90204-06M00	10 - 3	90386-44M99	20 - 11	90480-09M21	13 - 3
64D-82581-00	30 - 9	66T-W0090-02-1S	2 - 1	90119-10M04	20 - 24		11 - 4	90386-52M02	20 - 8	90480-10155	10 - 20
688-82586-21	28 - 49	66T-W0093-01	32 - 16	90141-06M00	2 - 19	90206-12052	13 - 12	90387-05M11	15 - 13	90480-10M23	10 - 23
688-82586-50	30 - 18	676-W2810-01	6 - 33	90142-05M06	23 - 9		14 - 6	90387-06035	13 - 4	90480-10M71	8 - 26
6R5-82588-01	30 - 3	90101-06020	19 - 20	90149-05M05	30 - 14	90206-12M00	18 - 29	90387-06119	9 - 3	90480-25161	9 - 11
688-8258A-20	28 - 49	90101-08002	2 - 21	90149-05M13	14 - 25	90206-43M22	14 - 34	90387-06M60	10 - 24	90480-25M70	24 - 27
66T-82590-00	10 - 14	90101-08M28	18 - 59	90149-14M12	18 - 2	90209-10M26	15 - 11	90387-06M66	7 - 27	90480-30M71	24 - 28
66T-82590-20	11 - 1	90101-08M76	18 - 15	90157-05014	18 - 49	90209-27012	3 - 12	90387-06M80	4 - 16	90501-10M84	16 - 6
703-82591-00	28 - 53	90101-08M86	20 - 14	90157-05M19	25 - 4	90209-52M00	20 - 7	90387-06M86	14 - 3	90501-15M01	23 - 52
703-82592-00	28 - 54	90101-09M01	26 - 7	90159-06034	4 - 15	90243-04007	18 - 5	90387-07M05	18 - 44	90501-23215	14 - 27
65W-82594-00	10 - 33	90101-10M58	18 - 62	90161-06M00	10 - 34	90249-07M32	18 - 54	90387-07M29	18 - 55	90502-10M06	18 - 60
701-82594-00	29 - 44	90101-12M65	19 - 33	90170-06M30	10 - 2	90249-07M33	18 - 56	90387-08M05	7 - 35	90506-16M34	13 - 16
703-82594-00	28 - 25	90105-08M61	23 - 50		11 - 3	90249-10M31	18 - 43	90387-08M16	16 - 3	90506-20M37	18 - 47
703-83383-02	28 - 51	90105-08M76	20 - 3	90170-09M03	26 - 5	90249-12M34	18 - 33	90387-08M29	18 - 14	90506-30M00	18 - 57
688-83383-11	30 - 13	90109-05M89	15 - 14	90170-12138	23 - 37	90249-12M38	19 - 16	90387-10M42	26 - 6	91318-04025	21 - 39
66T-83557-00	10 - 15	90109-06M80	9 - 7	90170-20137	8 - 21	90249-12M39	18 - 35	90387-12M04	18 - 34	91490-16012	16 - 22
6N7-83557-00	10 - 15		10 - 13	90171-16011	24 - 23	90249-18M35	19 - 29	90389-22M01	24 - 22	91490-20010	14 - 20
6A1-83625-41	7 - 43		13 - 29	90179-10M33	20 - 25	90250-06023	23 - 53	90430-08020	23 - 5	91490-20012	18 - 58
61T-83625-80	7 - 44		16 - 20	90185-08045	20 - 12	90254-03M04	16 - 24		33 - 4	91490-30025	24 - 24
6E0-83627-41	14 - 45	90109-06M81	9 - 6	90185-08057	18 - 32		17 - 5	90430-12072	24 - 3	91690-30018	18 - 13
61T-83627-80	14 - 46		13 - 7	90185-09M01	26 - 4	90254-03M05	16 - 16	90445-07M08	2 - 38		19 - 5
66T-85515-00	8 - 8		16 - 18	90185-10051	20 - 4	90266-04M01	1 - 7	90445-07M24	4 - 8	91690-40032	4 - 23
66T-85520-00	8 - 10	90109-06M86	10 - 30	90185-10M13	19 - 32	90266-04M04	1 - 5	90445-07MA4	4 - 9	92780-06025	29 - 20
66T-85533-00	8 - 14		13 - 15	90185-10M14	15 - 12	90269-02M09	14 - 24	90445-09086	6 - 13	92903-05100	30 - 11
	34 - 2		14 - 15	90185-22043	18 - 24	90280-03M03	23 - 17	90445-09M08	6 - 4	92903-06600	4 - 7
66T-85540-00	9 - 5	90109-06M88	15 - 4	90185-22M11	19 - 12		33 - 19	90445-09M75	2 - 37		7 - 38
66T-8554B-01-94	9 - 1	90109-08M90	18 - 30	90201-08M00	19 - 26	90280-05015	8 - 20	90445-11M05	25 - 11	92990-05100	6 - 23
66T-85550-00	8 - 1	90110-10M02	19 - 30	90201-08M07	18 - 31	90338-05M03	13 - 25	90445-11M06	25 - 9		30 - 16
66T-85550-10	8 - 1	90116-10M23	22 - 20	90201-08M54	16 - 11	90338-07M00	13 - 24	90445-11M78	31 - 16	92990-05600	5 - 5
66T-85560-01	8 - 2	90116-10M28	20 - 5	90201-10120	17 - 8	90340-08002	23 - 4	90446-03MA3	9 - 12		10 - 11
66T-85560-11	8 - 2	90119-06M61	13 - 2		20 - 30	90385-12M04	7 - 34	90446-10M86	14 - 31		30 - 17
66T-85561-00	8 - 3	90119-06M65	9 - 4	90201-10M02	14 - 26	90386-07MA2	18 - 41	90446-10M87	14 - 30	92990-06100	15 - 5
66T-85570-00	9 - 10	90119-06M73	13 - 17	90201-10M20	26 - 3	90386-08032	14 - 28	90464-09M49	13 - 30	92990-06200	14 - 11
66T-85580-00	8 - 5	90119-06M88	10 - 26	90201-10M63	26 - 8	90386-10M99	18 - 40	90464-12M00	8 - 27	92990-06300	29 - 25
66T-85582-00	8 - 7	90119-06MA3	2 - 27	90201-12426	18 - 64	90386-12M37	13 - 10	90464-13249	7 - 42	92990-06600	23 - 32
66T-85596-00	8 - 6	90119-06MA5	2 - 32		19 - 35	90386-12M98	18 - 27	90465-11M10	11 - 14	92990-08100	18 - 17
6J4-86111-00	10 - 17	90119-08M03	4 - 12	90201-12M07	14 - 5		19 - 15	90465-13M11	19 - 18	92990-08600	28 - 34
66T-86112-00	10 - 19	90119-08M10	7 - 32	90201-20417	3 - 20	90386-12MA0	18 - 36	90465-13M36	31 - 12	92990-10100	22 - 22
6J4-86116-00	10 - 18	90119-08M15	23 - 25	90201-21M18	8 - 22		19 - 14	90465-15M74	8 - 23	92990-10600	22 - 23

NUMERICAL INDEX
INDICE NUMERICO

PART NO. CODIGO N°	REF. NO.	PART NO. CODIGO N°	REF. NO.	PART NO. CODIGO N°	REF. NO.	PART NO. CODIGO N°	REF. NO.	PART NO. CODIGO N°	REF. NO.	PART NO. CODIGO N°	REF. NO.
92995-06200	14 - 9	93210-46M16	4 - 11	95380-05600	30 - 15	97880-05030	10 - 10				
92995-06600	2 - 13		32 - 9	95380-06600	28 - 40	97880-06035	16 - 7				
	6 - 3	93210-48MG8	23 - 22		29 - 46	97885-06008	20 - 28				
	7 - 26		33 - 8	95380-06700	16 - 8	97902-04108	8 - 9				
	8 - 19	93210-50768	21 - 29		23 - 28	97902-06125	8 - 15				
	9 - 15	93210-54M54	4 - 14	95380-08600	6 - 11		34 - 3				
	11 - 13		32 - 10		18 - 16	97980-04112	5 - 9				
	13 - 28	93210-59MG7	23 - 15	95380-10600	18 - 65	97980-04125	31 - 15				
	19 - 24		33 - 5		22 - 21	97980-05125	5 - 26				
92995-08100	20 - 18	93210-65M50	2 - 11	95380-10700	14 - 38		32 - 28				
	24 - 10		32 - 4	95380-12600	19 - 36	98503-05028	6 - 22				
92995-08200	20 - 13	93210-69MG6	23 - 46	95780-06300	14 - 8	98580-03015	28 - 38				
92995-08600	12 - 11		33 - 11	95780-10300	14 - 39	98580-04006	28 - 36				
	22 - 7	93210-74MG5	23 - 47	97013-06014	6 - 12	98580-04010	28 - 35				
92995-10100	24 - 13		33 - 12	97013-06030	7 - 37	98580-05010	28 - 37				
92995-10600	18 - 63	93210-75M51	8 - 17	97013-06035	4 - 6		29 - 32				
	19 - 31		32 - 15	97075-08030	20 - 17	98580-05020	29 - 42				
	20 - 23	93306-001U1	23 - 45		22 - 6	99080-08600	18 - 42				
	24 - 14	93306-306V5	3 - 8	97075-10040	24 - 12	9E471-04305	8 - 12				
92995-12200	19 - 34	93306-307U0	3 - 6	97075-10070	20 - 22						
93101-16001	2 - 10	93310-727U0	3 - 13	97080-08016	19 - 25						
	32 - 3	93315-32224	23 - 11	97095-06010	7 - 30						
93101-22M00	23 - 49	93317-22204	23 - 48	97095-06012	9 - 17						
	33 - 13	93332-00001	23 - 34	97095-06014	16 - 13						
93101-22M60	23 - 20	93332-00003	23 - 39		19 - 23						
	33 - 7	93332-000UE	3 - 7	97095-06016	8 - 24						
93102-30M56	2 - 9	93420-30042	22 - 17		11 - 12						
	32 - 2	93430-06024	28 - 10		13 - 27						
93102-35008	8 - 4		29 - 35	97095-06020	2 - 12						
	32 - 14	93430-10M00	18 - 37	97095-06025	9 - 14						
93210-03261	10 - 25		19 - 17	97095-06030	6 - 2						
93210-03478	21 - 52	93440-68M03	3 - 14	97095-06035	7 - 25						
93210-064A5	21 - 26	93501-08001	21 - 60	97095-06040	6 - 28						
93210-06ME6	23 - 31	93603-21111	3 - 19		8 - 18						
	33 - 10	93604-08062	23 - 24	97095-08016	12 - 10						
93210-08006	21 - 51	93606-12019	22 - 3	97095-08025	24 - 9						
93210-08287	25 - 14		24 - 11	97095-08035	24 - 16						
93210-09165	21 - 35	93608-12063	2 - 6	97095-08045	16 - 12						
93210-10M74	21 - 32	93700-06M03	15 - 2	97303-05012	30 - 10						
93210-11073	21 - 54		18 - 19	97380-05025	28 - 8						
93210-11368	21 - 24		19 - 8	97380-08030	28 - 33						
93210-16275	26 - 10	94702-00040	2 - 39	97390-06018	29 - 22						
93210-18397	21 - 45	94702-00272	2 - 39	97575-08545	22 - 10						
93210-32738	6 - 9	95303-05700	30 - 12	97595-06550	14 - 4						
	32 - 11	95380-03600	6 - 19	97780-50616	1 - 3						
93210-33MG4	23 - 30	95380-05600	10 - 12	97802-04006	8 - 16						
	33 - 9		23 - 10		34 - 4						
93210-43MJ0	20 - 10		28 - 7	97880-05008	10 - 21						