



PARTS CATALOGUE

EK25BMH'10 (69TA)

EK25CMH'10 (6S65)

EK25BMH/EK25CMH
PARTS CATALOGUE
©2009 by Yamaha Motor Co., Ltd.
1st edition, August 2009
All rights reserved.
Any reprinting or unauthorized use
without the written permission of
Yamaha Motor Co., Ltd.
is expressly prohibited.
Printed in Japan.

FOREWORD

This Parts Catalogue is related to the parts for the model(s) on the cover page. When you are ordering replacement parts, please refer to this Parts Catalogue and quote both part numbers and part names correctly.

1. Modifications or additions which have been made after the issue of the Parts Catalogue will be announced in the Parts News.
It is advisable that you make the necessary corrections to the Parts Catalogue according to the Parts News.

2. Abbreviations

The following abbreviations are used in this Parts Catalogue.

“UR” Use specified parts number.

“UN” Use as many as needed.

“AP” Alternate Parts

“LM” Locally Made (Parts need to be ordered locally)

“F#” Frame No. (Applicable machine No.)

“O/S” Over Size

3. The number of components for assembly

- Parts, which are to be supplied in an assembly, are listed with a dot (.) in front of the part name as shown below.
- The numeral appearing to the right of each component part indicates the quantity of parts for each assembly unit.

PART NO.	DESCRIPTION	Q'TY	REMARKS
2F5-83310-60	FRONT FLASHER LIGHT ASSY	2	
115-83311-60	.BULB (6V-18W)	1	

4. Applicable colours of graphics are represented in the “REMARKS” as shown below.

PART NO.	DESCRIPTION	Q'TY	REMARKS
2N4-24110-00-X5	FUEL TANK COMP.	2	MXR
3J1-24240-10	.GRAPHIC, FUEL TANK	1	FOR MXR

5. Note that the illustrations for reference in finding parts numbers are not to be used for assembling. When assembling, please use the applicable service manual.

6. The asterisk (*) before a reference number indicates modified items after the first edition.

7. Applicable Serial No.

Engine Serial No.

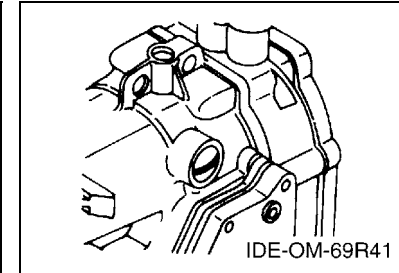
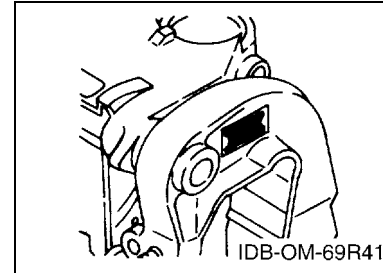

8. Applicable Engine Starting Serial No.

Model	Serial No.	Model	Serial No.
EK25B	62CK-1003532	EK25C	6S6K-1000456

9. Applicable Colour Code

Abbreviation	Colour Name	Colour Code
DBNM2	DARK BLUISH GRAY METALLIC 2	004D

10. Quantity Column Information

Column No.	Name Of Q'ty Column	Applicable Model
1	69TA	EK25BMH
2	6S65	EK25CMH

CONTENTS

TOP COWLING	1
CYLINDER & CRANKCASE	2
CRANKSHAFT & PISTON	4
INTAKE	5
CARBURETOR	7
FUEL 1	10
FUEL 2	12
STARTER	13
GENERATOR	15
ELECTRICAL	16
BOTTOM COWLING	18
STEERING	19
CONTROL	20
BRACKET 1	22
BRACKET 2	24
UPPER CASING	26
LOWER CASING & DRIVE 1	27
LOWER CASING & DRIVE 2	30
FUEL TANK	31
REPAIR KIT 1	32
REPAIR KIT 2	34

INDEX

NUMERICAL INDEX	36
-----------------------	----

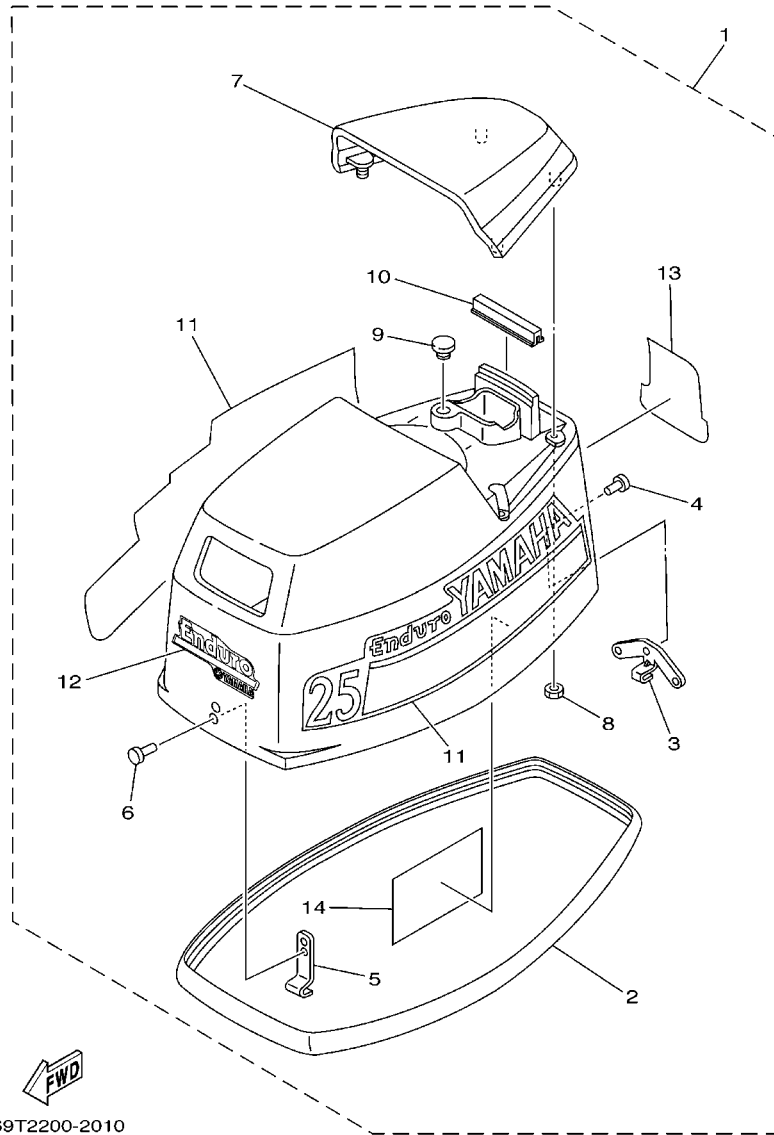

FIG. 1 TOP COWLING

REF. NO.	PART NO.	DESCRIPTION	69TA	6S85			REMARKS
			1	1			
1	69T-42610-K0-4D	TOP COWLING ASSY	1	1			
2	6G0-42615-00	.SEAL	1	1			
3	689-42647-00	.HOLDER, CLAMP BAND	1	1			
4	90266-04M01	.RIVET	3	3			
5	6G0-42651-02	.HOOK	1	1			
6	90266-04M00	.RIVET	2	2			
7	69P-42613-00-4D	.MOLDING, AIR DUCT	1	1			
8	90179-06M24	.NUT	4	4			
9	90480-14M14	.GROMMET	1	1			
10	61N-42628-00	.SEAL	1	1			
11	61N-W0070-H0	.GRAPHIC SET	1	1			
12	69P-42677-H0	.GRAPHIC, FRONT	1	1			
13	62C-42678-K0	.GRAPHIC, REAR	1	1			
14	6B8-13437-00	.MARK, CAUTION	1	1			

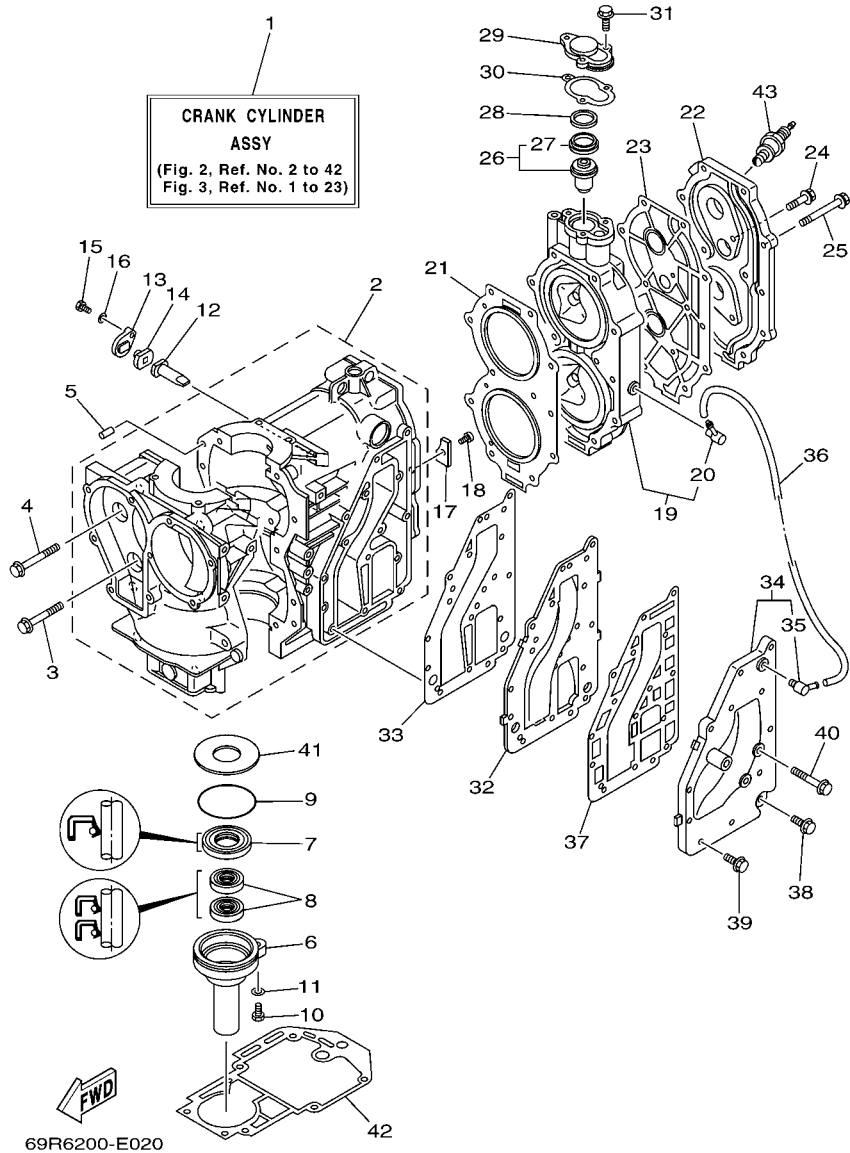

FIG. 2 CYLINDER & CRANKCASE

REF. NO.	PART NO.	DESCRIPTION	69TA	6S85		REMARKS
1	69T-W0090-00-1S	CRANK CYLINDER ASSY	1	1		
2	69P-15100-00-1S	CRANKCASE ASSY	1	1		
3	90119-08009	BOLT, WITH WASHER	2	2		
4	90119-08M65	BOLT, WITH WASHER	8	8		
5	93606-12019	PIN, DOWEL	2	2		
6	689-15396-01-5B	HOUSING, OIL SEAL	1	1		
7	93102-25008	OIL SEAL	1	1		
8	93101-16001	OIL SEAL	2	2		
9	93210-58M21	O-RING	1	1		
10	97095-06022	BOLT	1	1		
11	92995-06600	WASHER	1	1		
12	6J8-11325-00	ANODE	1	1		
13	6H3-11327-00-1S	COVER, ANODE	1	1		
14	6H3-11328-00	GROMMET, ANODE	1	1		
15	97013-06016	BOLT	1	1		
16	92903-06600	WASHER, PLATE	1	1		
17	689-11325-00	ANODE	1	1		
18	90151-06M02	SCREW, COUNTERSUNK	1	1		
19	62C-11111-00-1S	HEAD, CYLINDER 1	1	1		
20	676-11372-00	.NIPPLE, HOSE	1	1		
21	61N-11181-A2	GASKET, CYLINDER HEAD 1	1	1		
22	61N-11191-01-1S	COVER, CYLINDER HEAD 1	1	1		
23	61T-11193-A1	GASKET, HEAD COVER 1	1	1		
24	90119-06MA2	BOLT, WITH WASHER	2	2		
25	90119-08015	BOLT, WITH WASHER	11	11		
26	6F5-12411-03	THERMOSTAT	1	1		
27	6E5-12412-00	.SEAL, THERMOSTAT	1	1		

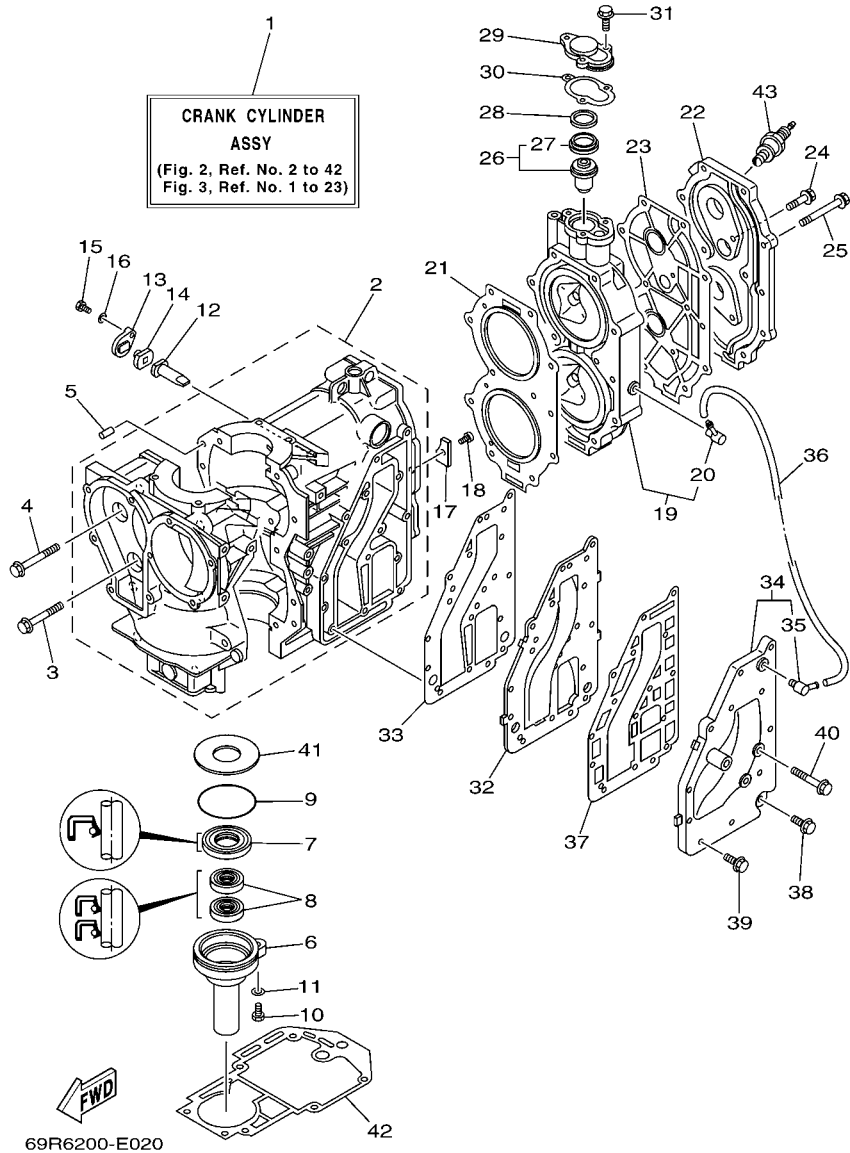
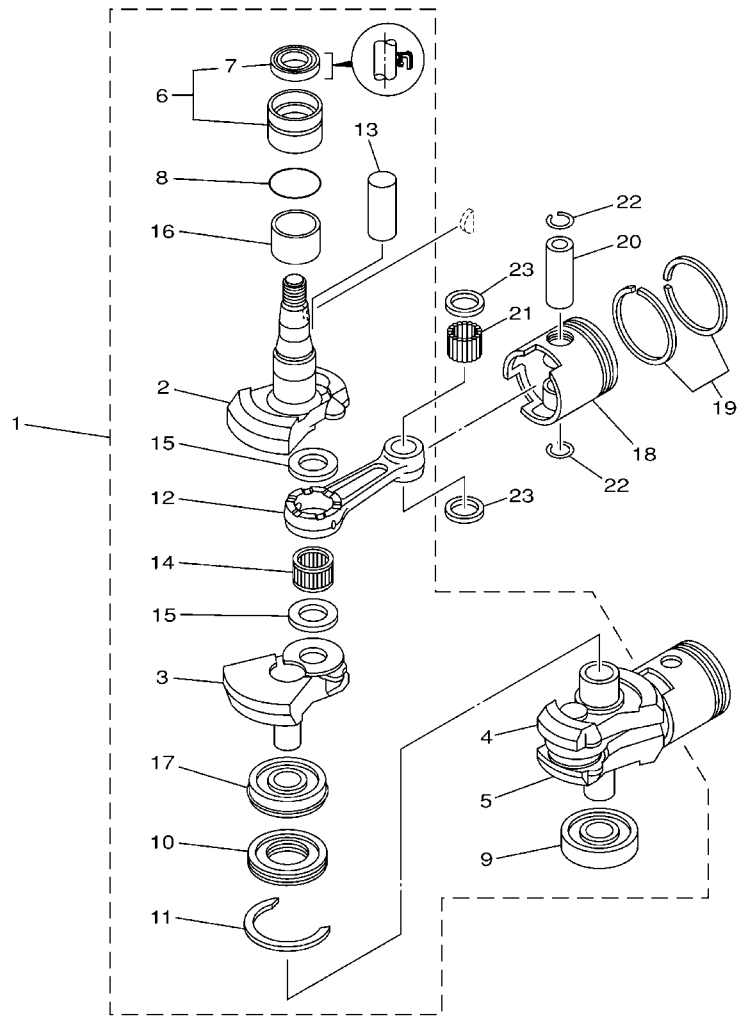

FIG. 2 CYLINDER & CRANKCASE

REF. NO.	PART NO.	DESCRIPTION	69TA	6S85	REMARKS
28	90201-21567	WASHER, PLATE	1	1	
29	655-12413-01-1S	COVER, THERMOSTAT	1	1	
30	655-12414-A1	GASKET, COVER	1	1	
31	90119-06MA2	BOLT, WITH WASHER	3	3	
32	6K8-41121-00-1S	INNER COVER, EXHAUST	1	1	
33	6K8-41122-A1	GASKET, EXHAUST INNER COVER	1	1	
34	61N-41123-01-1S	OUTER COVER, EXHAUST	1	1	
35	676-11372-00	.NIPPLE, HOSE	1	1	
36	90445-10M41	HOSE (L105)	1	1	
37	6K8-41124-A1	GASKET, EXHAUST OUTER COVER	1	1	
38	90119-06MA3	BOLT, WITH WASHER	1	1	
39	90119-06MA4	BOLT, WITH WASHER	11	11	
40	90119-06MA0	BOLT, WITH WASHER	3	3	
41	90201-50306	WASHER, PLATE	1	1	
42	689-45113-A1	GASKET, UPPER CASING	1	1	
43	94702-00217	PLUG, SPARK (NGK B7HS-10)	2	2	



 69R0010-1030

FIG. 3 CRANKSHAFT & PISTON

REF. NO.	PART NO.	DESCRIPTION	69TA	6S85		REMARKS
1	69T-11400-00	CRANKSHAFT ASSY	1	1		
2	69P-11412-00	.CRANK 1	1	1		
3	61N-11422-00	.CRANK 2	1	1		
4	61N-11432-00	.CRANK 3	1	1		
5	61N-11442-00	.CRANK 4	1	1		
6	93399-99951	.BEARING	1	1		
7	93102-32M07	..OIL SEAL	1	1		
8	93210-46M16	.O-RING	1	1		
9	93306-305U3	.BEARING	1	1		
10	61N-11515-00	.SEAL, LABYRINTH 1	1	1		
11	93440-62057	.CIRCLIP	1	1		
12	689-11651-00	.ROD, CONNECTING	2	2		
13	689-11681-01	.PIN, CRANK 1	2	2		
14	93310-62406	.BEARING	2	2		
15	90202-24M32	.WASHER, PLATE	4	4		
16	90387-32002	.COLLAR	1	1		
17	93390-00009	.BEARING	1	1		
18	61N-11631-00-95	PISTON (STD)	2	2		
	61N-11635-00	PISTON (0.25MM O/S)	2	2		AP
	61N-11636-00	PISTON (0.50MM O/S)	2	2		AP
19	61N-11603-00	PISTON RING SET (STD)	2	2		
	61N-11604-00	PISTON RING SET (0.25MM O/S)	2	2		AP
	61N-11605-00	PISTON RING SET (0.50MM O/S)	2	2		AP
20	689-11633-00	PIN, PISTON	2	2		
21	93602-20M02	PIN, DOWEL	68	68		
22	688-11634-00	CLIP, PISTON PIN	4	4		
23	90201-20M27	WASHER, PLATE	4	4		

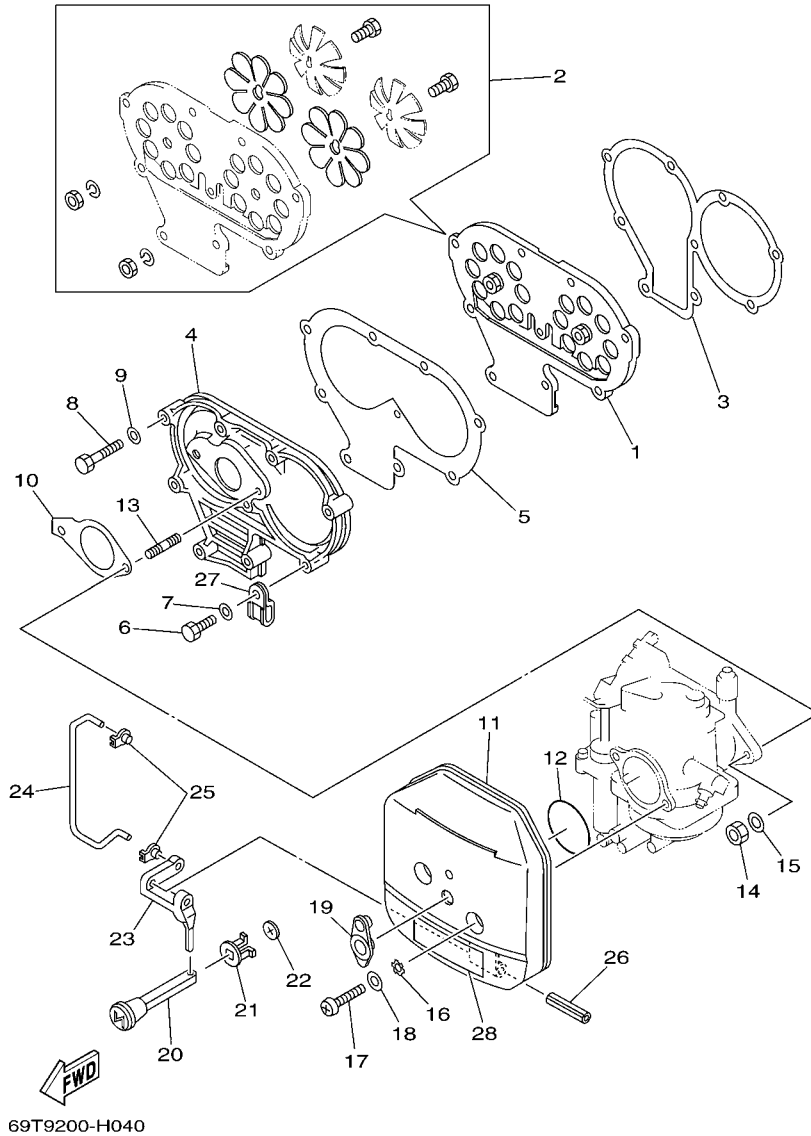
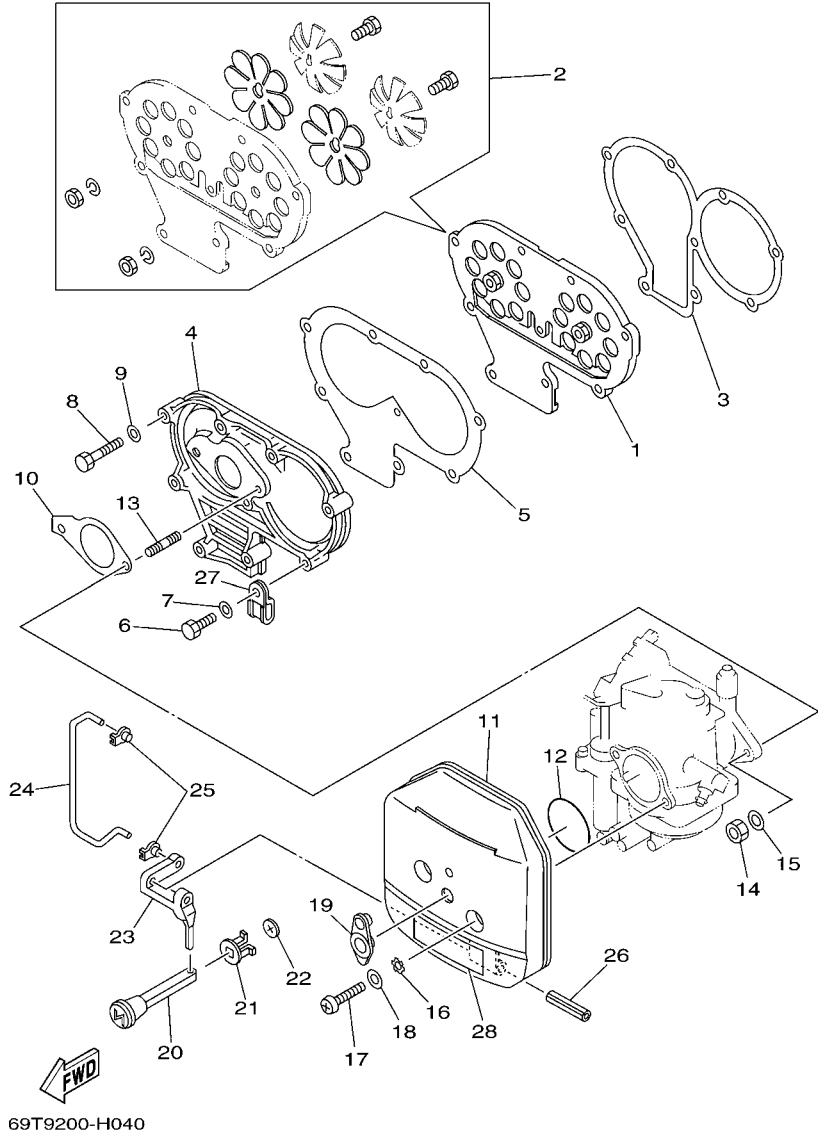

FIG. 4 INTAKE

REF. NO.	PART NO.	DESCRIPTION	69TA	6S85			REMARKS
1	6J0-13610-00	REED VALVE ASSY	1	1			
2	689-W0004-60	.REED SET	1	1			
3	648-13621-A1	GASKET, VALVE SEAT	1	1			
4	648-13641-02-1S	MANIFOLD 1	1	1			
5	648-13645-A0	GASKET, MANIFOLD 1	1	1			
6	97013-06025	BOLT	2	2			
7	92903-06600	WASHER, PLATE	2	2			
8	97013-06035	BOLT	7	7			
9	92903-06600	WASHER, PLATE	7	7			
10	648-14198-A0	GASKET	1	1			
11	62C-14440-01	SILENCER ASSY, INTAKE	1	1			
12	93210-39M89	O-RING	1	1			
13	90116-06M08	BOLT, STUD	2	2			
14	95380-06600	NUT, HEXAGON	2	2			
15	92995-06600	WASHER	2	2			
16	90209-05M24	WASHER	2	2			
17	97880-05030	SCREW, PAN HEAD	2	2			
18	92990-05600	WASHER, PLATE	2	2			
19	62C-14435-00	GROMMET	1	1			
20	682-41271-00	KNOB, CHOKE	1	1			
21	689-41273-00	GROMMET	1	1			
22	6J8-41274-00	GROMMET 2	1	1			
23	6J0-41252-00	LEVER, CHOKE 1	1	1			
24	62C-41256-00	ROD, CHOKE 1	1	1			
25	661-41262-02	JOINT, CHOKE LEVER	2	2			
26	91690-40040	PIN, SPRING	1	1			
27	90461-06M01	CLAMP	1	1			

FIG. 4 INTAKE



REF. NO.	PART NO.	DESCRIPTION	69TA	6S85					REMARKS
28	6AH-81994-40	LABEL, SAFETY	1	1					
<hr/>									
<hr/>									
<hr/>									
<hr/>									
<hr/>									
<hr/>									
<hr/>									
<hr/>									
<hr/>									
<hr/>									

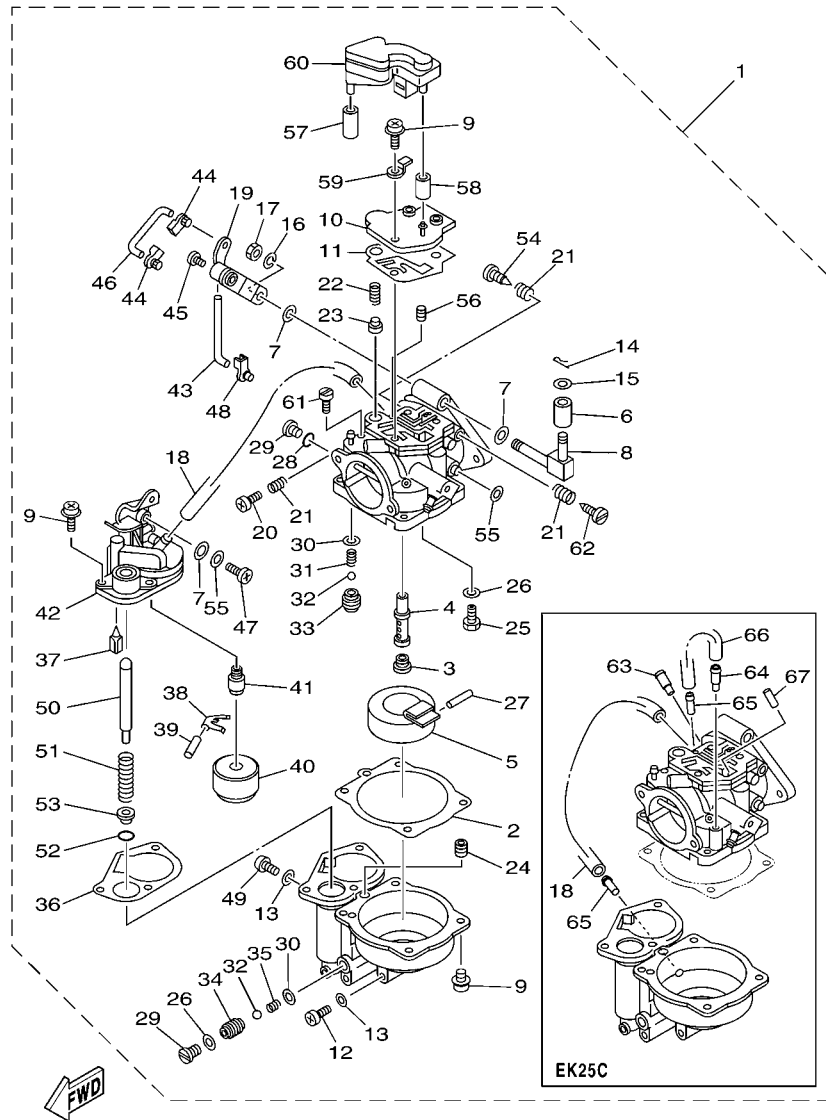

69T6200-E050

FIG. 5 CARBURETOR

REF. NO.	PART NO.	DESCRIPTION	69TA	6S85	REMARKS
1	69T-14301-00	CARBURETOR ASSY 1	1		
	69T-14301-20	CARBURETOR ASSY 1		1	
2	6A4-14384-00	.GASKET, FLOAT CHAMBER	1	1	
3	648-14343-78	.JET, MAIN (#155)	1		
	648-14343-70	.JET, MAIN (#140)		1	
4	6J0-14341-00	.NOZZLE, MAIN	1	1	
5	648-14385-00	.FLOAT	1	1	
6	69T-41231-00	.COLLAR, GUIDE PIN	1	1	
7	69T-14367-00	.COLLAR	3	3	
8	69T-41216-00	.SHEAVE SHAFT, ACCEL. LINK	1	1	
9	97980-04112	.SCREW, WITH WASHER	10	10	
10	6A4-14346-01	.PLATE	1	1	
11	6A4-14398-01	.GASKET	1	1	
12	98580-04015	.SCREW, PAN HEAD	1	1	
13	6L2-14398-00	.GASKET	2	2	
14	91490-16010	.PIN, COTTER	1	1	
15	62Y-14597-00	.WASHER	1	1	
16	92990-05100	.WASHER, SPRING	1	1	
17	95380-05700	.NUT	1	1	
18	6J0-14348-00	.PIPE 1	1		
	6S6-1410E-00	.HOSE		1	
19	69T-14310-00	.ACCEL ARM ASSY	1	1	
20	664-14321-01	.SCREW, THROTTLE	1	1	
21	646-14212-01	.SPRING, PILOT ADJUSTING	3	3	
22	656-14335-00	.SPRING, PLUNGER	1	1	
23	62C-14371-00	.PLUNGER, STARTER	1	1	
24	6J0-14344-43	.JET, STARTER (# 86)	1	1	

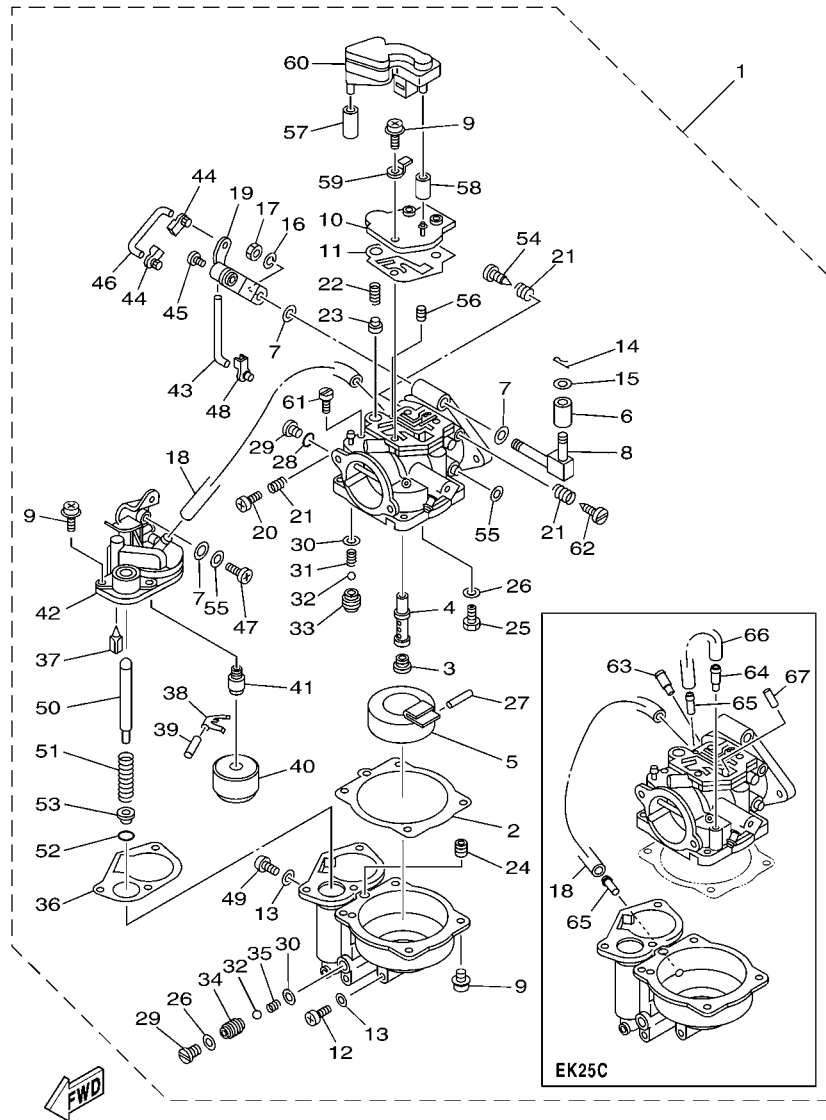

69T6200-E050

FIG. 5 CARBURETOR

REF. NO.	PART NO.	DESCRIPTION	69TA	6S85		REMARKS
25	6J0-14390-14	.NEEDLE VALVE ASSY	1	1		
26	367-14195-00	.GASKET	2	2		
27	689-14386-00	.PIN, FLOAT	1	1		
28	652-14397-00	.O-RING	1	1		
29	6A4-14394-00	.SCREW, DRAIN	2	2		
30	6F5-14372-01	.SEAT, PACKING	2	2		
31	6F5-14332-01	.SPRING	1	1		
32	6A4-14369-01	.BALL	2	2		
33	6A4-14355-00	.SEAT, BALL	1	1		
34	6A4-14355-10	.SEAT, BALL	1	1		
35	6A4-14332-00	.SPRING, AIR VALVE	1	1		
36	6J0-14384-00	.GASKET, FLOAT CHAMBER	1	1		
37	62C-14392-00	.VALVE, NEEDLE	1	1		
38	6J0-14387-00	.ARM, FLOAT	1	1		
39	6A4-14386-00	.PIN, FLOAT	1	1		
40	652-14385-00	.FLOAT	1	1		
41	6J0-14342-24	.JET, PILOT (# 48)	1	1		
42	6J0-14182-00	.COVER, FLOAT CHAMBER	1			
	6J0-14182-20	.COVER, FLOAT CHAMBER		1		
43	6J0-14379-10	.ROD, STARTER	1	1		
44	6F5-41262-01	.JOINT, THROTTLE LEVER	2	2		
45	677-14327-01	.SCREW	1	1		
46	62C-14379-00	.ROD, STARTER	1	1		
47	6J0-14329-01	.SCREW	1	1		
48	661-41262-02	.JOINT, CHOKE LEVER	1	1		
49	97890-04005	.SCREW, PAN HEAD	1	1		
50	69T-14370-00	.PLUNGER STARTER ASSY	1	1		

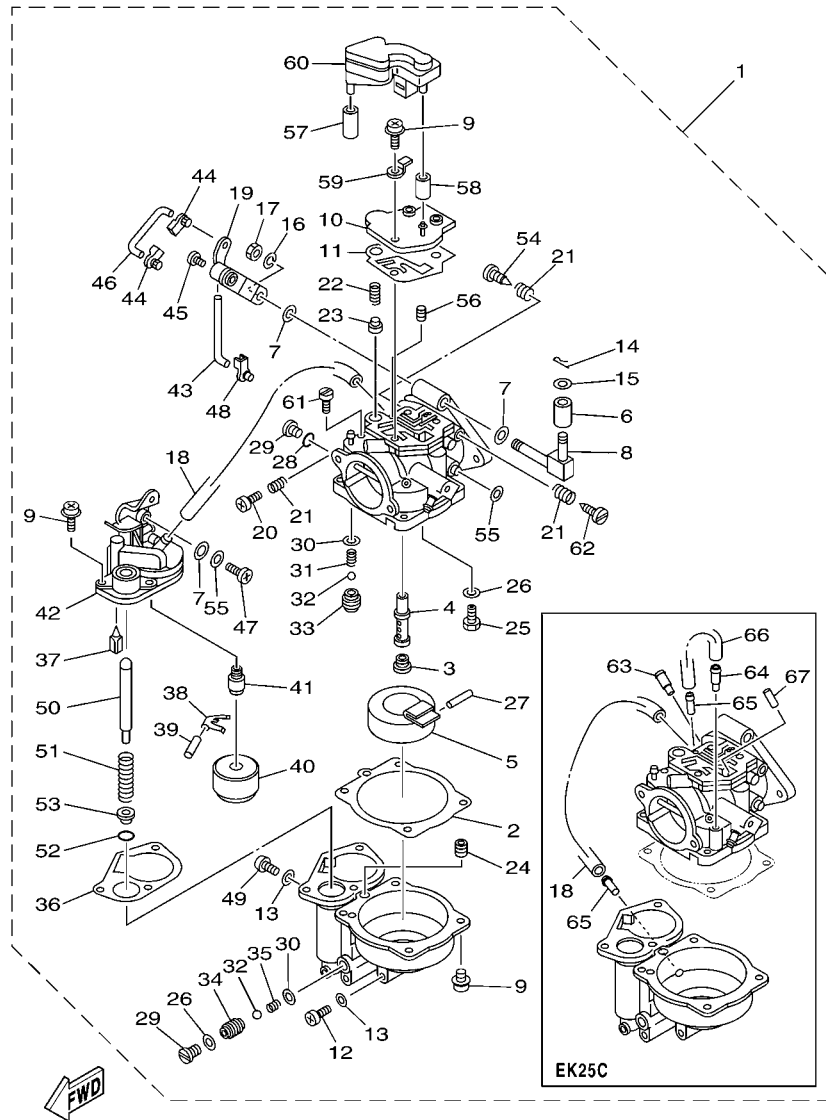

69T6200-E050

FIG. 5 CARBURETOR

REF. NO.	PART NO.	DESCRIPTION	69TA	6S85	REMARKS
51	6A4-14339-01	.SPRING	1	1	
52	652-14147-00	.O-RING	1	1	
53	6A4-13945-00	.CHECK VALVE ASSY.	1	1	
54	647-14323-00	.SCREW, AIR ADJUSTING	1	1	
55	6L2-14357-00	.WASHER, PLAIN	2	2	
56	6J0-14353-25	.JET, PILOT (# 50)	1	1	
57	90445-09M55	.HOSE (L20)	1	1	
58	90445-09M69	.HOSE (L15)	1	1	
59	6A4-14146-00	.PLATE	1	1	
60	6A4-14225-00	.DAMPER	1	1	
61	62C-14326-00	.SCREW, GUIDE	1	1	
62	6J0-14323-00	.SCREW, AIR ADJUSTING	1	1	
63	69T-14342-25	.JET, PILOT (#50)	1		
64	69T-14353-40	.JET, PILOT (#79)	1		
65	69T-14196-00	.PIPE, OVER FLOW 1	2		
66	69T-14987-00	.HOSE	1		
67	69T-14337-00	.AIR JET, MAIN (#150)	1		

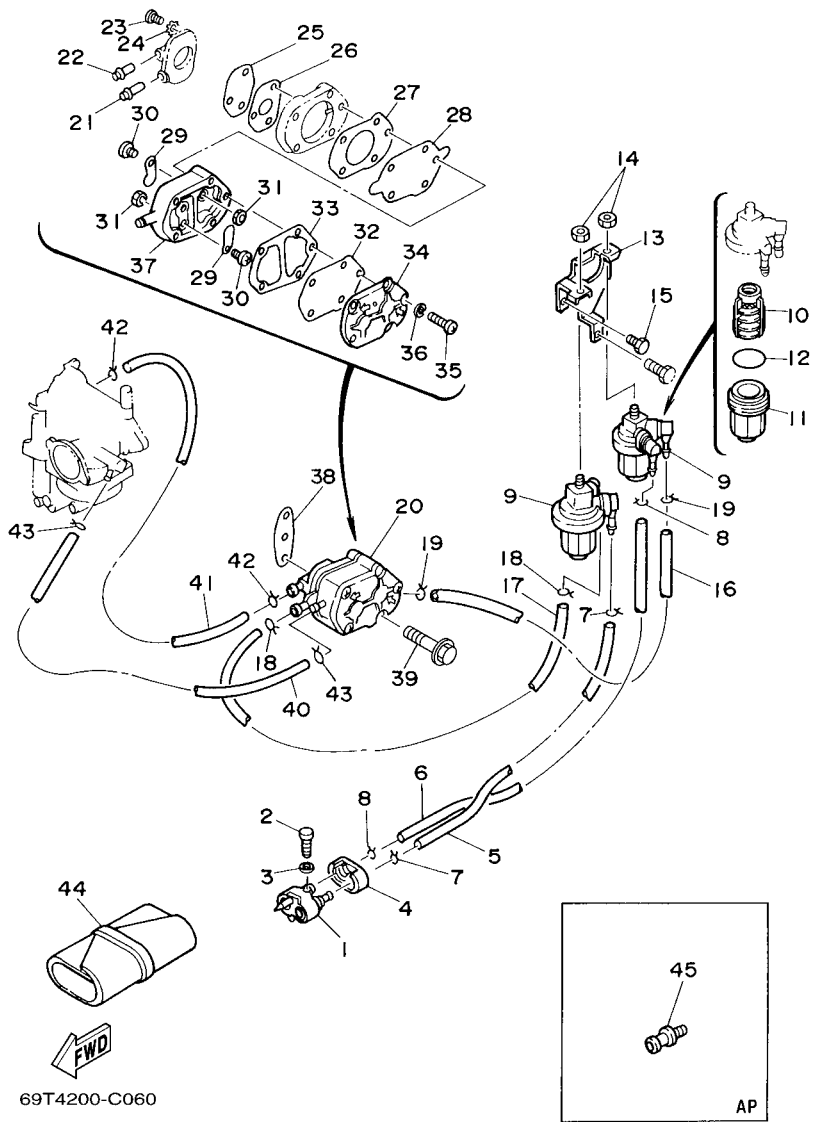

FIG. 6 FUEL 1

REF. NO.	PART NO.	DESCRIPTION	69TA	6S85	REMARKS
1	680-24304-01	FUEL PIPE JOINT COMP. 1	1	1	
2	97095-06020	BOLT	1	1	
3	92995-06600	WASHER	1	1	
4	6A4-24329-00	SEAL	1	1	
5	90445-09M75	HOSE (L370)	1	1	
6	90445-10M43	HOSE (L400)	1	1	
7	90467-08004	CLIP	2	2	
8	90467-09M03	CLIP	2	2	
9	61N-24560-00	FILTER ASSY	2	2	
10	61N-24563-00	.ELEMENT, FILTER	1	1	
11	61N-24521-00	.CUP, FILTER	1	1	
12	93210-32738	.O-RING	1	1	
13	62C-24566-01	BRACKET, FILTER	1	1	
14	95380-08600	NUT	2	2	
15	97095-06012	BOLT	1	1	
16	6A4-24314-00	PIPE 4	1	1	
17	6G0-24311-00	PIPE, FUEL 1	1	1	
18	90467-08004	CLIP	2	2	
19	90467-09M03	CLIP	2	2	
20	62C-24410-00	FUEL PUMP ASSY	1	1	
21	652-24461-00	.PIPE, JOINT	1	1	
22	62C-24461-00	.PIPE, JOINT	1	1	
23	98780-04010	.SCREW, FLAT HEAD	3	3	
24	92990-04500	.WASHER	3	3	
25	652-24471-00	.DIAPHRAGM	1	1	
26	652-24432-00	.GASKET, FUEL PUMP 2	1	1	
27	648-24434-01	.GASKET, BODY	1	1	

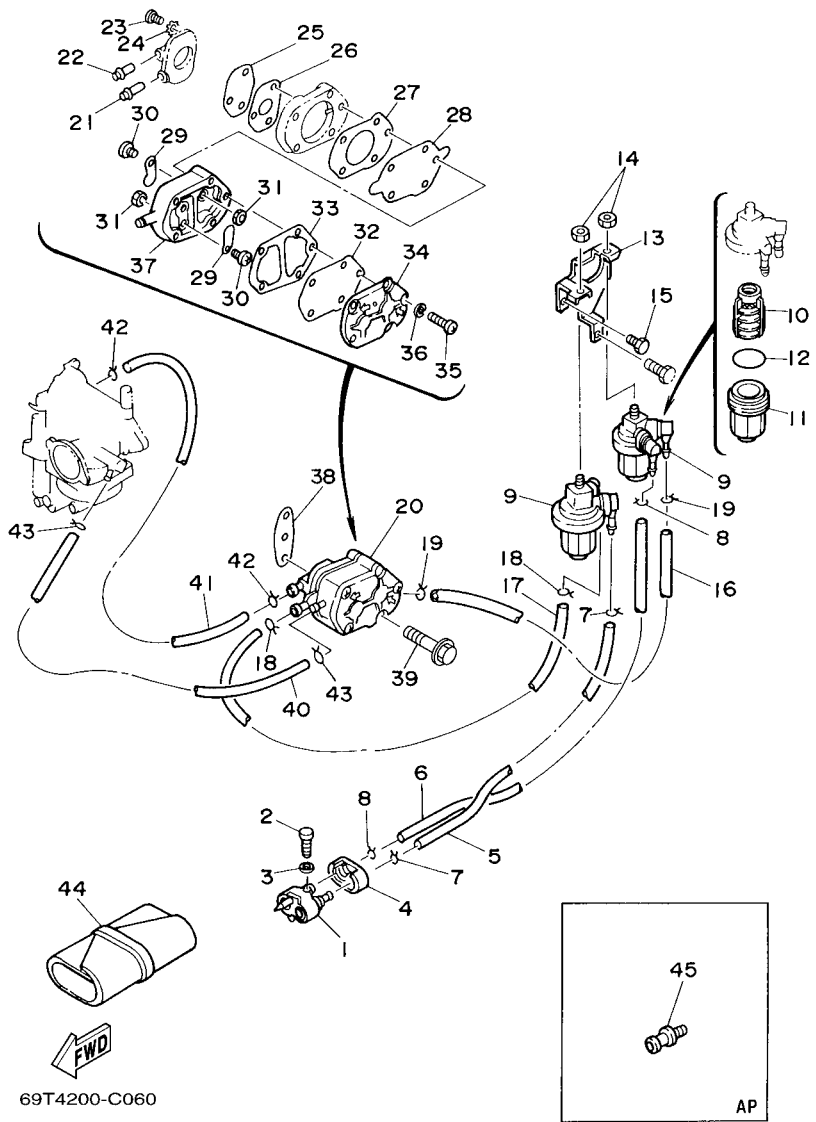
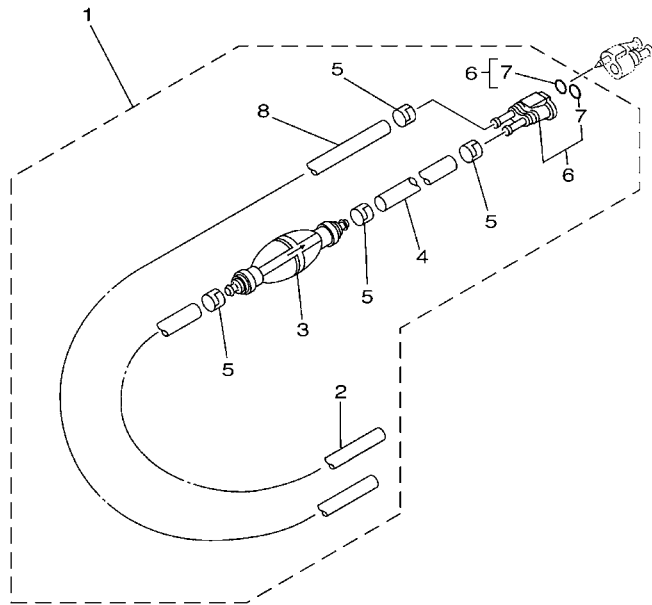

FIG. 6 FUEL 1

REF. NO.	PART NO.	DESCRIPTION	69TA	6S85	REMARKS
28	692-24411-00	.DIAPHRAGM	1	1	
29	6A0-24421-01	.VALVE, CHECK	2	2	
30	6A0-14325-00	.SCREW, PAN HEAD	2	2	
31	95380-03600	.NUT	2	2	
32	663-24411-00	.DIAPHRAGM	1	1	
33	648-24435-02	.GASKET, BODY 2	1	1	
34	6A0-24413-00	.BODY 2	1	1	
35	98503-05028	.SCREW, PAN HEAD	3	3	
36	92990-05100	.WASHER, SPRING	3	3	
37	6A0-24412-02	.BODY 1	1	1	
38	650-24431-A0	GASKET, FUEL PUMP 1	1	1	
39	97595-06550	BOLT, WITH WASHER	2	2	
40	90445-10M42	HOSE (L235)	1	1	
41	62C-24312-00	PIPE 2	1	1	
42	90467-08004	CLIP	2	2	
43	90467-09M03	CLIP	2	2	
44	656-W2810-02	TOOL KIT	1	1	
45	6E0-28193-00-94	PLUG, WATER CHECK	1	1	AP D:12.5MM
	626-28193-01-94	PLUG, WATER CHECK	1	1	AP D:15MM



6801200-2070

FIG. 7 FUEL 2

REF. NO.	PART NO.	DESCRIPTION	69TA	6S85				REMARKS
1	6Y3-24306-04	FUEL PIPE COMP. 1	1	1				AP FOR LKA
2	90445-11M06	.HOSE (L2050)	1	1				
3	61J-24360-00	.PRIMER PUMP ASSY	1	1				
4	90445-11M05	.HOSE (L850)	1	1				
5	650-24351-01	.BAND 1	4	4				
6	680-24305-01	.FUEL PIPE JOINT COMP. 2	1	1				
7	93210-08287	..O-RING	2	2				
8	90445-11M81	.HOSE (L3000)	1	1				

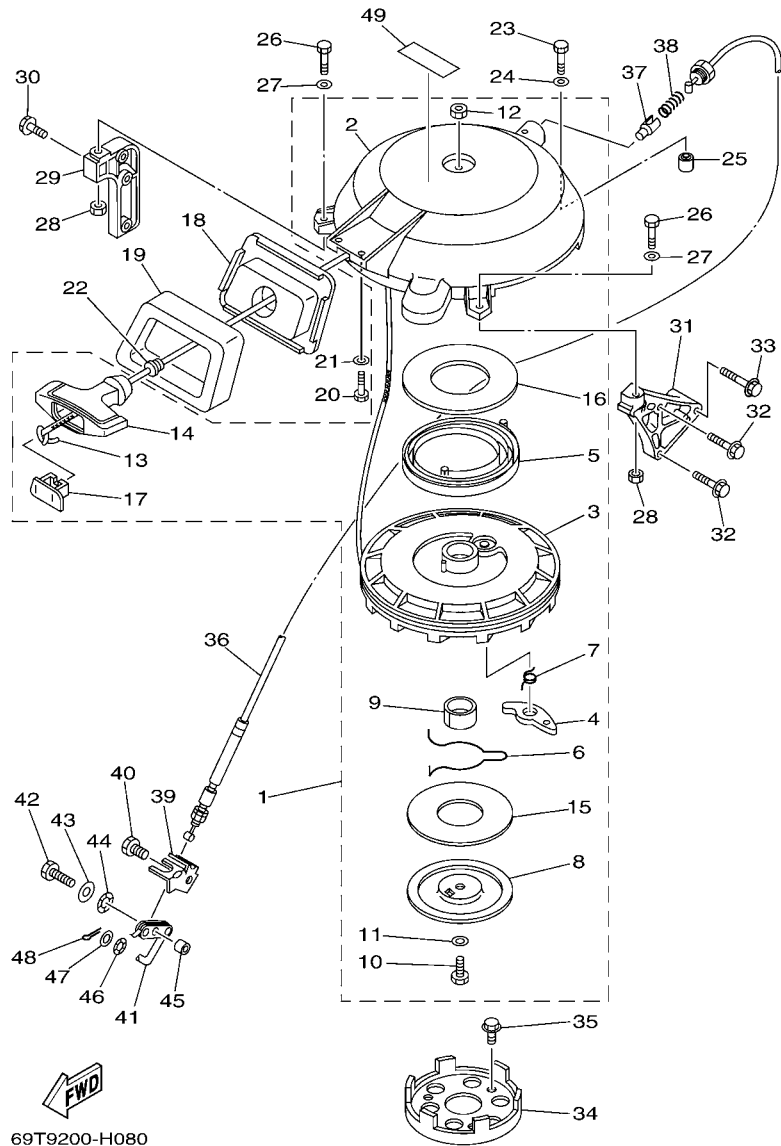

69T9200-H080

*1: CUT FROM 50M ROLLS, PART NO.90890-44373, CUTTING LENGTH 1.9M

FIG. 8 STARTER

REF. NO.	PART NO.	DESCRIPTION	69TA	6S85	REMARKS
1	61N-W1571-11	STARTER ASSY	1	1	
2	61N-15711-10	.CASE, STARTER	1	1	
3	6G0-15714-01	.DRUM, SHEAVE	1	1	
4	6F5-15741-01	.PAWL, DRIVE	1	1	
5	6F5-15713-01	.SPRING, STARTER	1	1	
6	61N-15715-00	.SPRING, FRICTION	1	1	
7	61N-15734-00	.SPRING, RETURN	1	1	
8	6F5-15716-01	.PLATE, DRIVE	1	1	
9	6G0-15754-00	.BUSH 2	1	1	
10	97013-08030	.BOLT	1	1	
11	6F5-15726-01	.WASHER, FLAT	1	1	
12	95303-08700	.NUT	1	1	
13	*	.WIRE (L:1900MM)	1	1	*1
14	689-15755-01	.HANDLE, STARTER	1	1	
15	6F5-15764-00	.COLLAR 1	1	1	
16	6F5-15739-00	.WASHER, THRUST	1	1	
17	6F5-15779-02	.COVER	1	1	
18	61N-15758-01-4D	GUIDE, ROPE	1	1	
19	61N-15762-00	SEAL, RUBBER 2	1	1	
20	97095-06016	BOLT	2	2	
21	92995-06600	WASHER	2	2	
22	6A0-15789-00	DAMPER	1	1	
23	97095-06035	BOLT	1	1	
24	92995-06600	WASHER	1	1	
25	99530-10014	PIN, DOWEL	1	1	
26	97095-06035	BOLT	2	2	
27	92995-06600	WASHER	2	2	

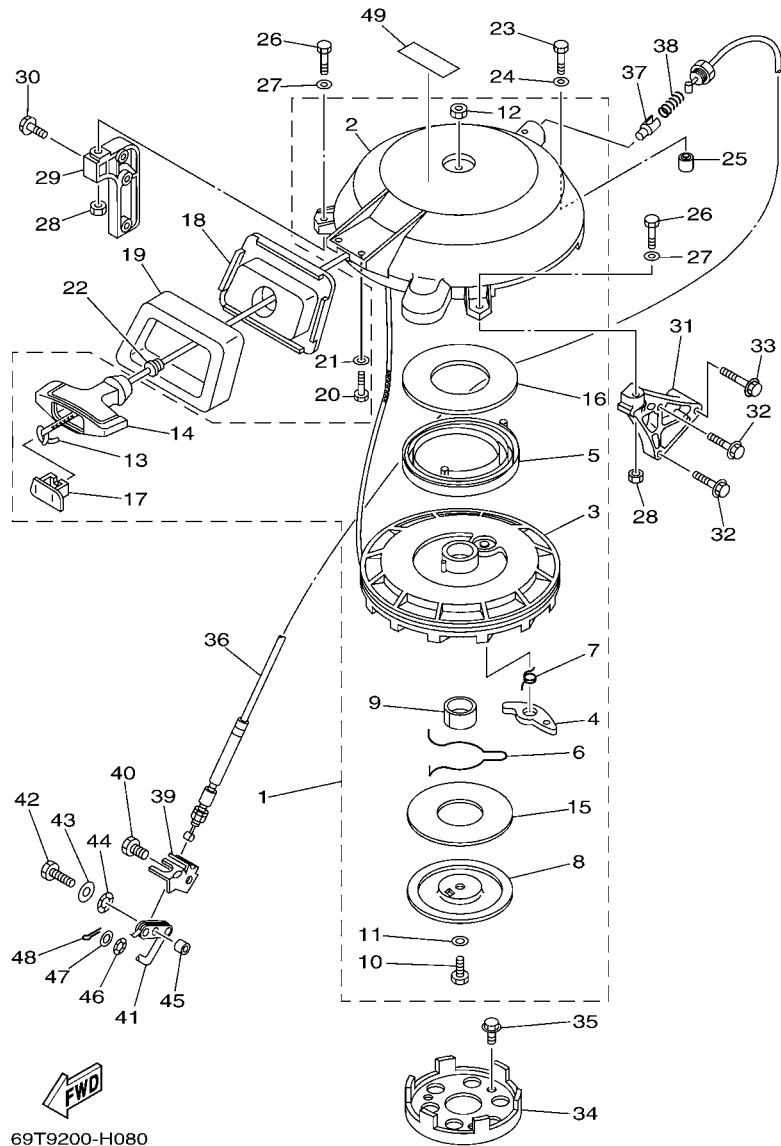

69T9200-H080

*1: CUT FROM 50M ROLLS, PART NO.90890-44373, CUTTING LENGTH 1.9M

FIG. 8 STARTER

REF. NO.	PART NO.	DESCRIPTION			REMARKS
			69TA	6S85	
28	95380-06600	NUT, HEXAGON	2	2	
29	656-15771-00-94	STAY 1	1	1	
30	90119-06MA3	BOLT, WITH WASHER	2	2	
31	656-15772-00-94	STAY 2	1	1	
32	90119-06MA3	BOLT, WITH WASHER	2	2	
33	90119-06025	BOLT, WITH WASHER	1	1	
34	6F5-15723-01	PULLEY, STARTER	1	1	
35	90105-08M10	BOLT, FLANGE	3	3	
36	61T-15770-00	CABLE COMP., STARTER STOP	1	1	
37	656-15748-00	PLUNGER, STARTER STOP	1	1	
38	90501-10227	SPRING, COMPRESSION	1	1	
39	61T-15774-40-94	STAY 4	1	1	
40	97095-06010	BOLT	1	1	
41	656-15749-00	LINK, STARTER STOP	1	1	
42	97095-06020	BOLT	1	1	
43	92903-06600	WASHER, PLATE	1	1	
44	90206-08010	WASHER, WAVE	1	1	
45	90387-06568	COLLAR	1	1	
46	90206-05005	WASHER, WAVE	1	1	
47	92903-05600	WASHER, PLATE	1	1	
48	91490-16010	PIN, COTTER	1	1	
49	6AH-81995-40	LABEL, WARNING	1	1	

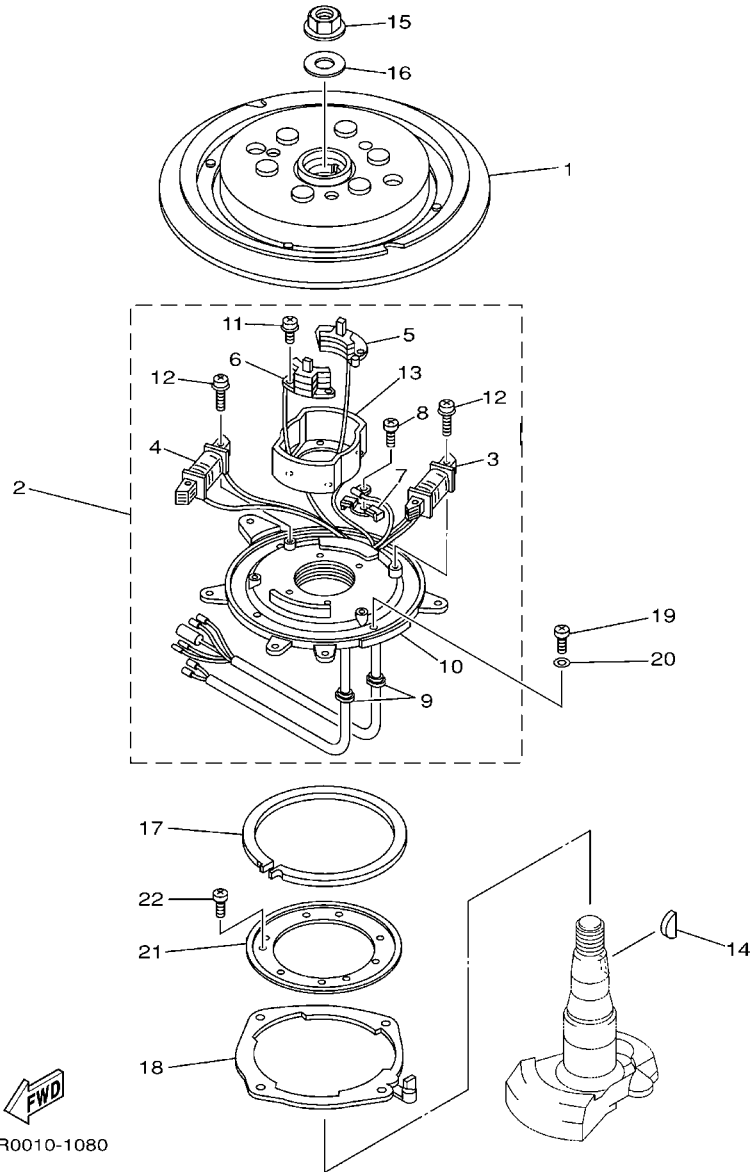

FWD
69R0010-1080

FIG. 9 GENERATOR

REF. NO.	PART NO.	DESCRIPTION	69TA	6S85	REMARKS
1	61N-85550-10	ROTOR ASSY	1	1	
2	69P-85560-00	BASE ASSY	1	1	
3	69P-85541-09	.COIL, CHARGE	1	1	
4	61N-81313-09	.COIL, LIGHTING 1	1	1	
5	61N-85543-09	.COIL, PULSER	1	1	
6	61N-85543-19	.COIL, PULSER	1	1	
7	6E9-81328-70	.CLAMP	1	1	
8	97802-04006	.SCREW, PAN HEAD	1	1	
9	6E9-85516-70	.GROMMET	2	2	
10	69P-85561-00	.BASE, MAGNETO	1	1	
11	97607-04112	.SCREW,WITH WASHER	4	4	
12	97607-06125	.SCREW,WITH WASHER	4	4	
13	61N-85537-00	.COVER	1	1	
14	90280-05015	KEY, WOODRUFF	1	1	
15	90179-16M05	NUT	1	1	
16	90201-16M44	WASHER, PLATE	1	1	
17	676-41611-00	RETAINER, MAGNETO BASE	1	1	
18	676-41613-00	PLATE, BASE FRICTION	1	1	
19	97880-05012	SCREW, PAN HEAD	4	4	
20	92990-05600	WASHER, PLATE	4	4	
21	689-41612-01	RETAINER, MAGNETO BASE	1	1	
22	97880-06010	SCREW, PAN HEAD	4	4	

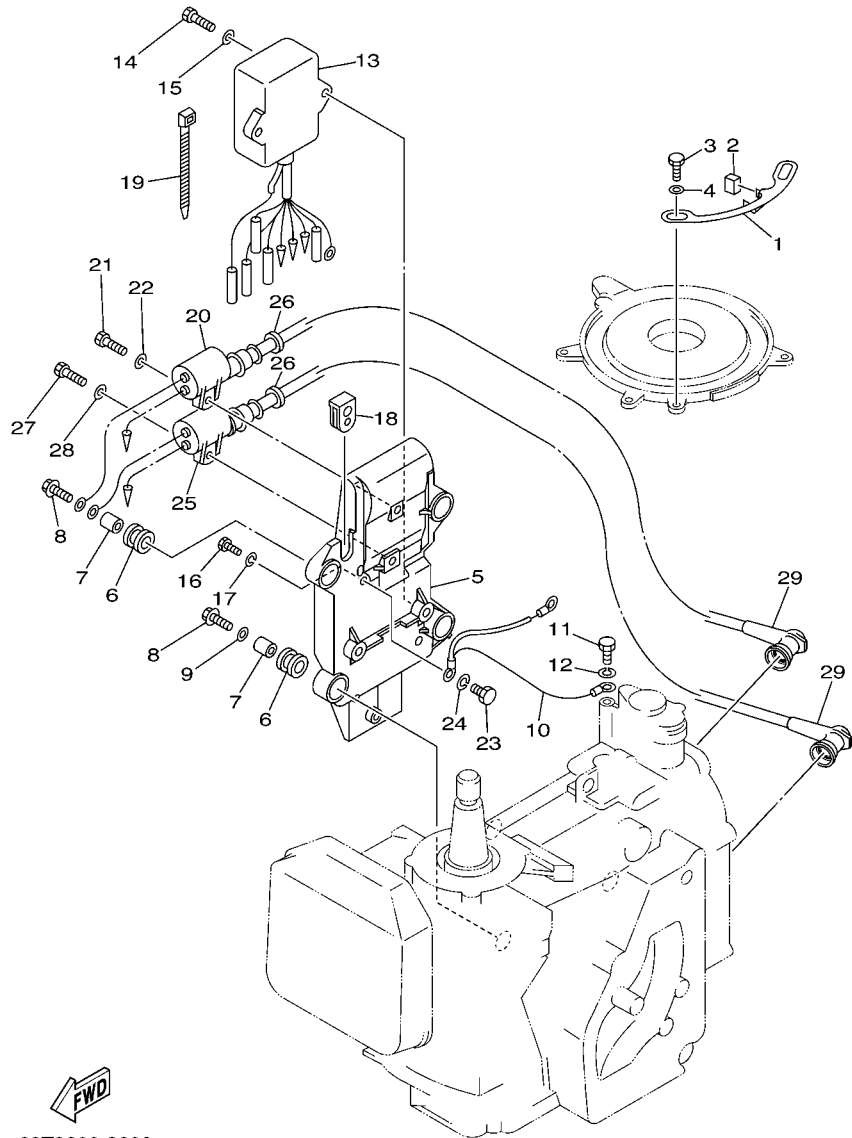

69T3200-3090



FIG. 10 ELECTRICAL

REF. NO.	PART NO.	DESCRIPTION	69TA	6S85	REMARKS
1	62C-41615-00	STOPPER, MAGNETO BASE	1	1	
2	695-44194-00	CAP	2	2	
3	97095-06010	BOLT	2	2	
4	92995-06600	WASHER	2	2	
5	61N-85542-00-94	BRACKET	1	1	
6	61N-82317-00	DAMPER, IGNITION COIL	4	4	
7	90387-06119	COLLAR	4	4	
8	90119-06M95	BOLT, WITH WASHER	4	4	
9	90201-06M30	WASHER, PLATE	2	2	
10	61N-82519-01	WIRE, EARTH LEAD	1	1	
11	97090-06012	BOLT	1	1	
12	92990-06100	WASHER, SPRING	1	1	
13	61N-85540-13	C.D.I. UNIT ASSY	1	1	
14	97095-06020	BOLT	2	2	
15	92995-06600	WASHER	2	2	
16	97090-06012	BOLT	1	1	
17	92990-06100	WASHER, SPRING	1	1	
18	6H3-81922-00	GROMMET	1	1	
19	90465-13M11	CLAMP	1	1	
20	61N-85570-00	IGNITION COIL ASSY	1	1	
21	97095-06020	BOLT	1	1	
22	92995-06600	WASHER	1	1	
23	97090-06012	BOLT	1	1	
24	92990-06100	WASHER, SPRING	1	1	
25	61N-85570-10	IGNITION COIL ASSY	1	1	
26	90480-25161	GROMMET	2	2	
27	97095-06020	BOLT	1	1	

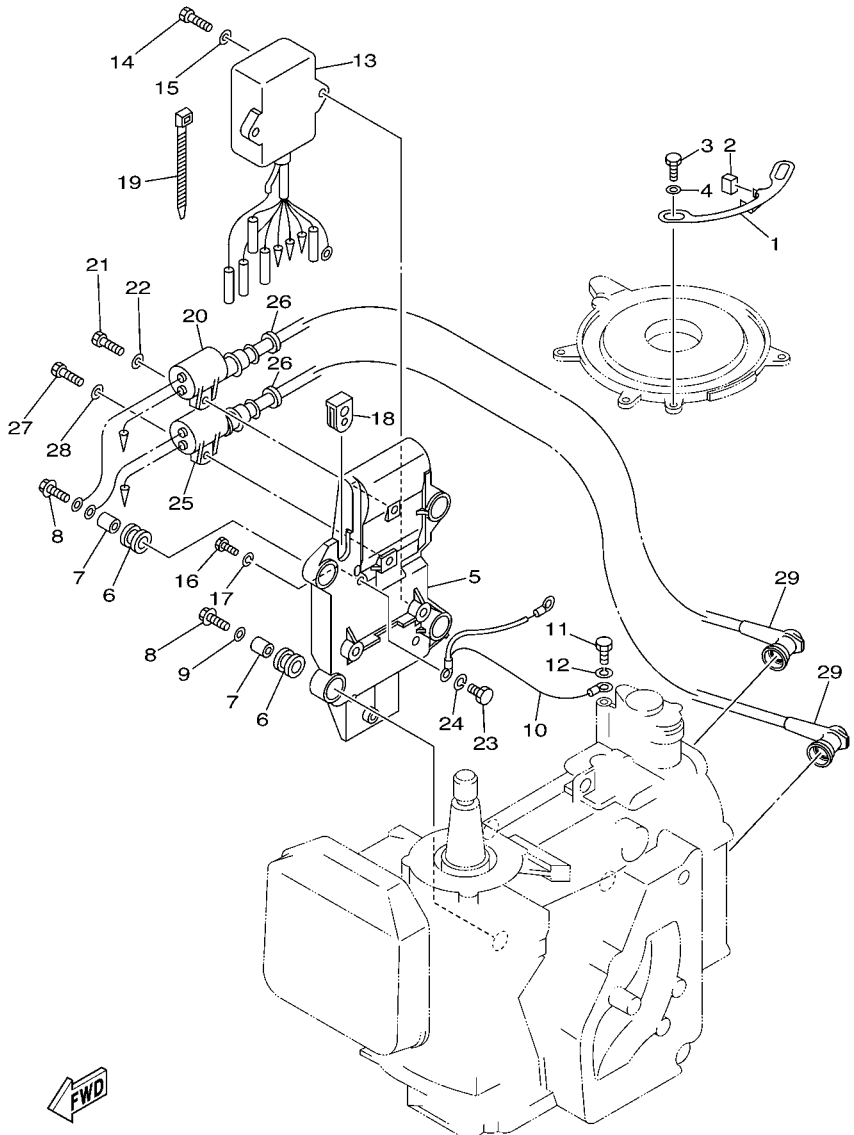
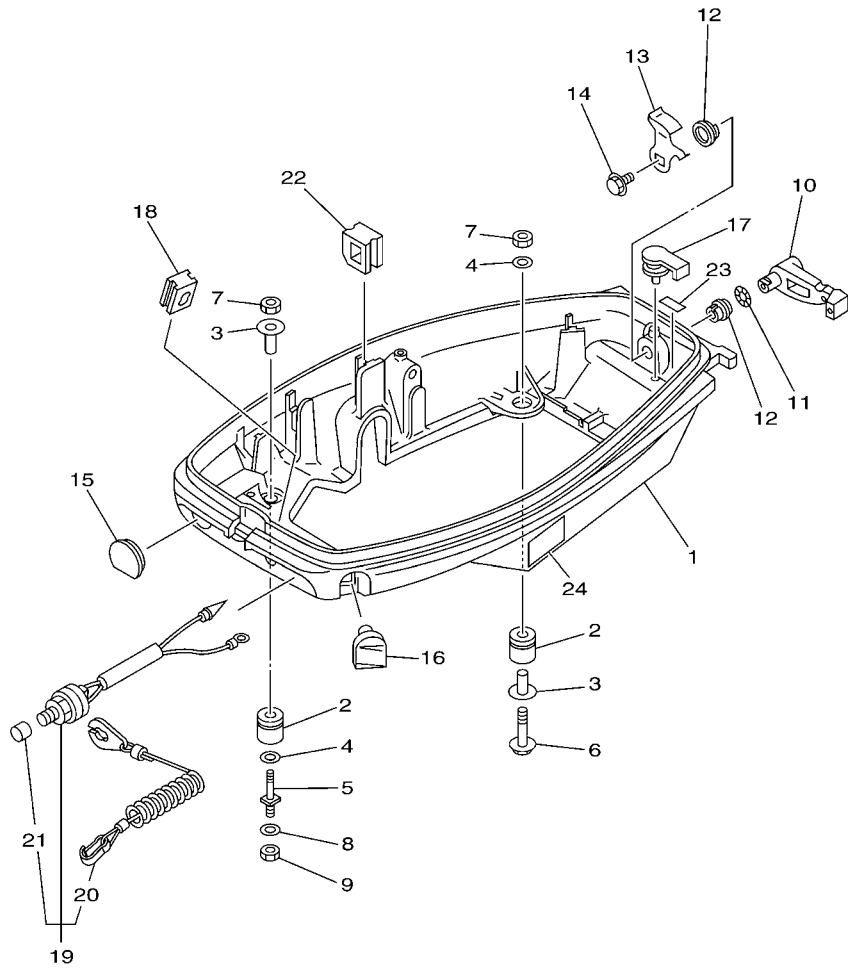

FIG. 10 ELECTRICAL

REF. NO.	PART NO.	DESCRIPTION	69TA	6S85		REMARKS
28	92995-06600	WASHER	1	1		
29	66T-82370-00	PLUG CAP ASSY	2	2		



69T9200-H110

FIG. 11 BOTTOM COWLING

REF. NO.	PART NO.	DESCRIPTION	69TA	6S85		REMARKS
1	6A4-42711-05-4D	COWLING, BOTTOM 1	1	1		
2	90480-15M06	GROMMET	4	4		
3	90387-08M25	COLLAR	4	4		
4	90201-08M87	WASHER, PLATE	4	4		
5	6G0-42796-00	BOLT 1	2	2		
6	97585-08540	BOLT, WITH WASHER	2	2		
7	95380-08700	NUT	4	4		
8	92990-08600	WASHER, PLATE	2	2		
9	95380-08700	NUT	2	2		
10	689-42815-00	LEVER, CLAMP	1	1		
11	90206-12052	WASHER, WAVE	1	1		
12	90386-12069	BUSH	2	2		
13	689-42816-00	LEVER, CLAMP	1	1		
14	90119-06M73	BOLT, WITH WASHER	1	1		
15	682-42724-00	GROMMET	1	1		
16	689-42725-01	GROMMET	1	1		
17	647-42523-00	SPACER, FRICTION	1	1		
18	61N-26326-00	GROMMET	1	1		
19	6E9-82575-02	ENGINE STOP SWITCH ASSY	1	1		
20	682-82556-00	.LANYARD, STOP SWITCH	1	1		
21	689-8257Y-00	.CAP	1	1		
22	90480-17M08	GROMMET	1	1		
23	6E7-42791-00	MARK 1	1	1		
24	6AH-42794-40	LABEL, WARNING (GENERAL)	1	1		

FIG. 12 STEERING

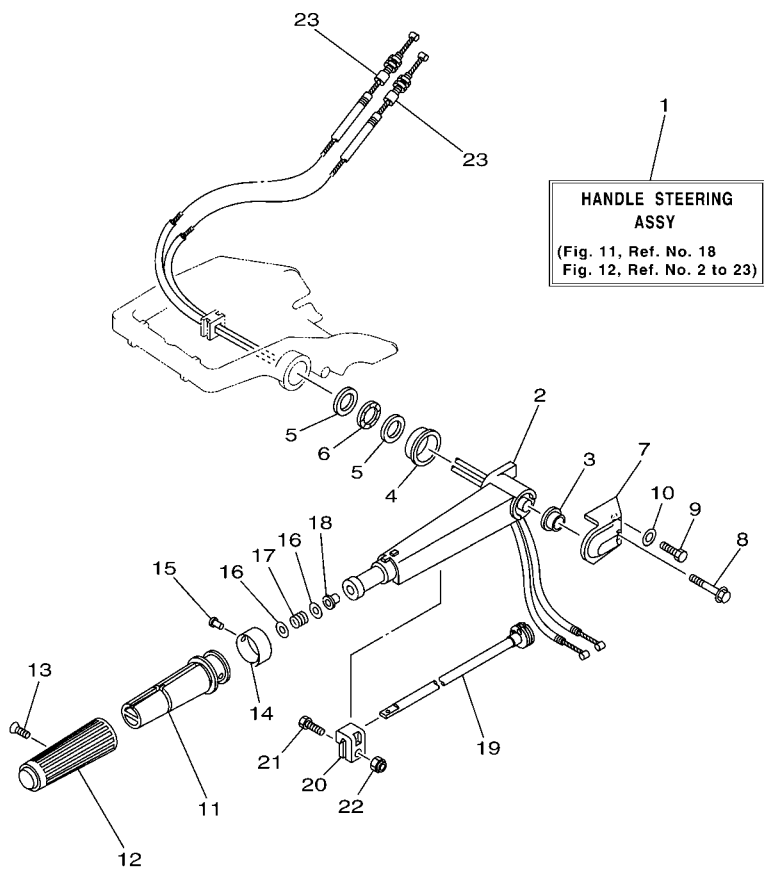

69T9200-H120

REF. NO.	PART NO.	DESCRIPTION	69TA	6S85	REMARKS
1	69T-W0084-00-4D	HANDLE STEERING ASSY	1	1	
2	689-42111-01-4D	HANDLE, STEERING	1	1	
3	90387-13003	COLLAR	1	1	
4	90387-33001	COLLAR	1	1	
5	90201-28013	WASHER, PLATE	2	2	
6	90206-28001	WASHER, WAVE	1	1	
7	69P-42112-00-4D	HANDLE, STEERING	1	1	
8	97595-06550	BOLT, WITH WASHER	1	1	
9	97095-06020	BOLT	1	1	
10	92995-06600	WASHER	1	1	
11	664-42119-00	GRIP, STEERING HANDLE	1	1	
12	6F6-42177-A0	RUBBER, HANDLE	1	1	
13	90149-05M13	SCREW	1	1	
14	6J0-42137-00	INDICATOR, THROTTLE	1	1	
15	90269-02M09	RIVET	1	1	
16	90201-10M02	WASHER, PLATE	2	2	
17	90501-23215	SPRING, COMPRESSION	1	1	
18	90386-08032	BUSH	1	1	
19	689-42138-00	LEVER, THROTTLE	1	1	
20	656-42126-01	FRICTION, STEERING HANDLE GRIP	1	1	
21	97095-06020	BOLT	1	1	
22	90185-06062	NUT, SELF-LOCKING	1	1	
23	62C-26311-00	CABLE, THROTTLE 1	2	2	

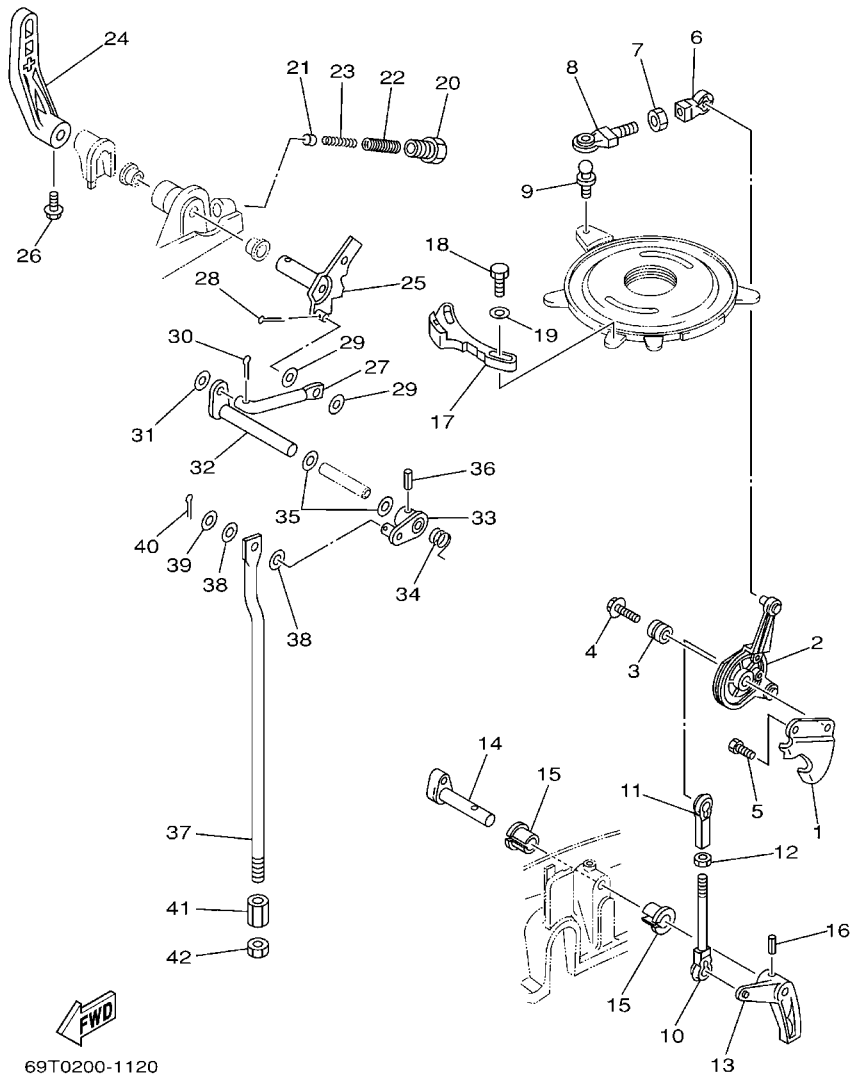

FIG. 13 CONTROL

REF. NO.	PART NO.	DESCRIPTION	69TA	6S85	REMARKS
1	689-14497-00	STAY, THROTTLE WIRE	1	1	
2	61N-41631-00-94	LEVER, MAGNETO CONTROL	1	1	
3	90387-06M02	COLLAR	1	1	
4	90119-06M49	BOLT, WITH WASHER	1	1	
5	97095-06012	BOLT	1	1	
6	662-41237-01	JOINT, LINK	1	1	
7	95380-05700	NUT	1	1	
8	679-41241-01	ROD, LINK	1	1	
9	663-85518-00	JOINT, BALL	1	1	
10	689-42169-01	JOINT	1	1	
11	662-41237-01	JOINT, LINK	1	1	
12	95380-05600	NUT	1	1	
13	689-42154-80-94	LEVER, THROTTLE CONTROL	1	1	
14	656-42153-00-94	SHAFT, THROTTLE CONTROL	1	1	
15	90386-10009	BUSH	2	2	
16	91690-40018	PIN, SPRING	1	1	
17	69T-41213-00	CAM, ACCEL.	1	1	
18	97095-05014	BOLT	2	2	
19	92995-05600	WASHER	2	2	
20	664-42715-00	BUSHING	1	1	
21	664-44167-01	PLUNGER, SHIFT CAM	1	1	
22	90501-14M07	SPRING, COMPRESSION	1	1	
23	90501-09M08	SPRING, COMPRESSION	1	1	
24	689-44111-01-4D	HANDLE, GEAR SHIFT	1	1	
25	664-44113-01	CAM PLATE, HANDLE	1	1	
26	90105-06M07	BOLT, FLANGE	1	1	
27	664-44142-00	JOINT	1	1	

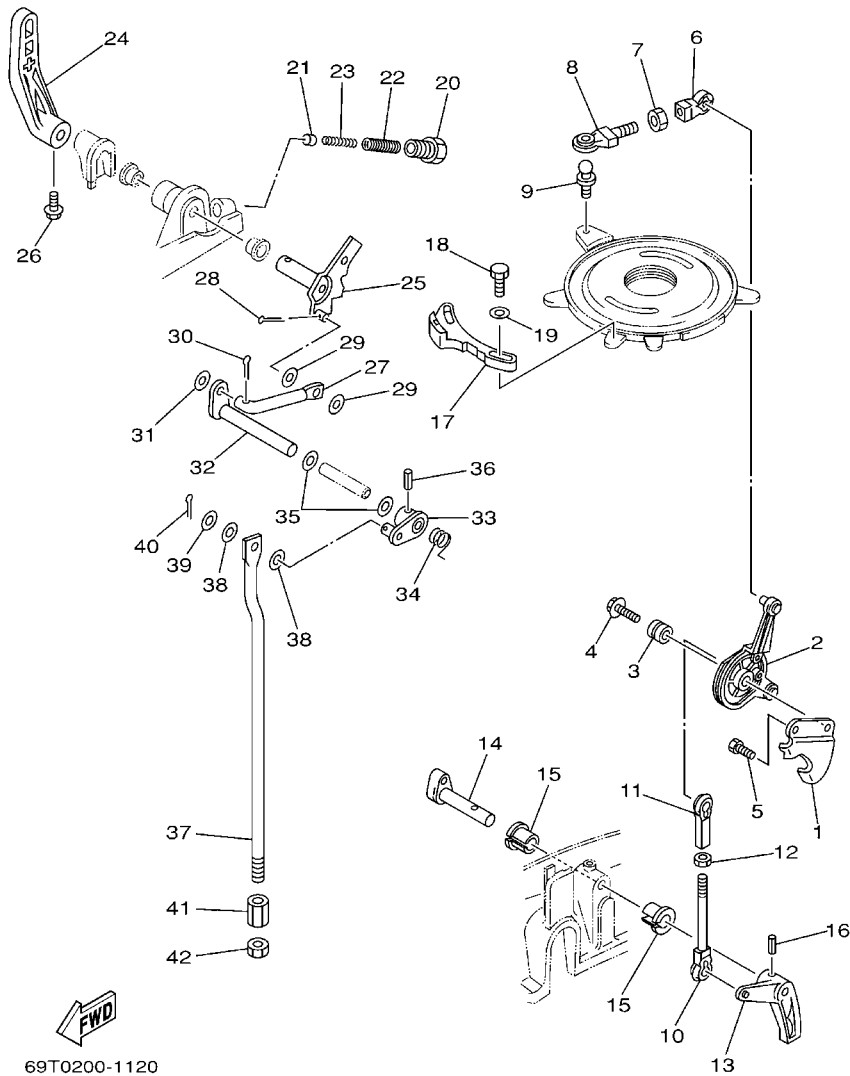
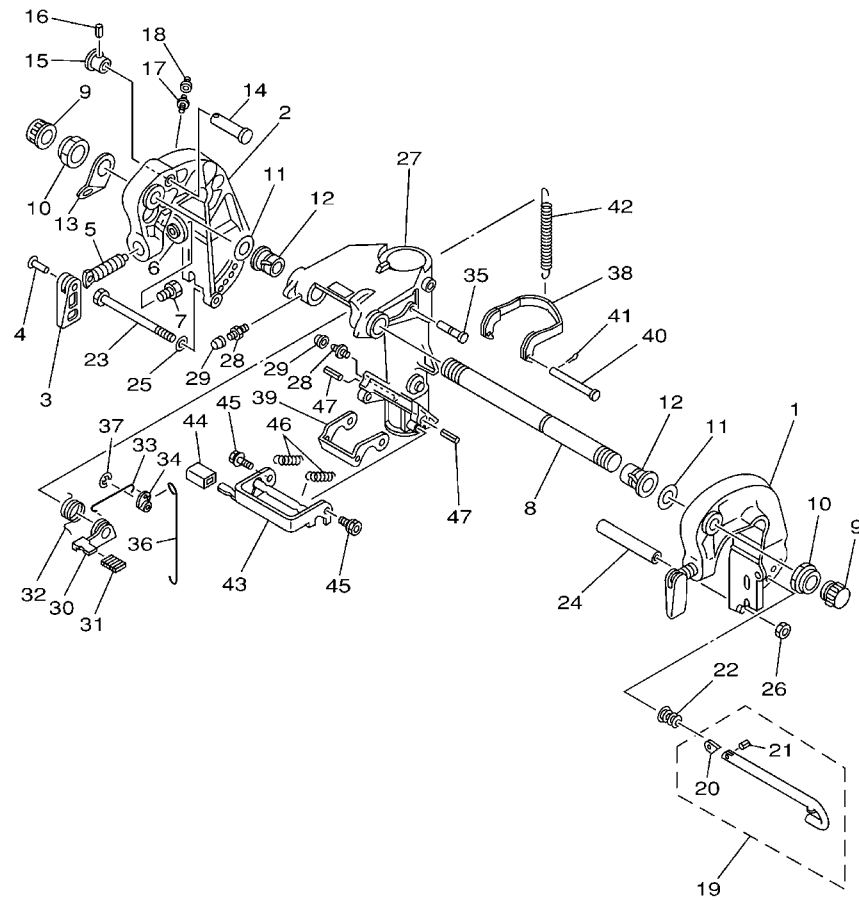

FIG. 13 CONTROL

REF. NO.	PART NO.	DESCRIPTION	69TA	6S85	REMARKS
28	91490-16010	PIN, COTTER	1	1	
29	90202-06007	WASHER, PLATE	2	2	
30	91490-12010	PIN, COTTER	1	1	
31	92990-05600	WASHER, PLATE	1	1	
32	689-44121-01	LEVER, SHIFT ROD	1	1	
33	689-44125-00	LEVER, SHIFT ROD	1	1	
34	90508-14M13	SPRING, TORSION	1	1	
35	90202-10024	WASHER, PLATE	2	2	
36	91690-40016	PIN, SPRING	1	1	
37	61N-44143-00	ROD, SHIFT	1	1	
38	90202-06007	WASHER, PLATE	2	2	
39	92990-05600	WASHER, PLATE	1	1	
40	91490-20010	PIN, COTTER	1	1	
41	61N-44146-00	CONNECTOR, SHIFT ROD	1	1	
42	95380-06600	NUT, HEXAGON	1	1	



69T0200-1130

FIG. 14 BRACKET 1

REF. NO.	PART NO.	DESCRIPTION	69TA	6S85	REMARKS
1	689-43111-03-4D	BRACKET, CLAMP 1	1	1	
2	689-43112-02-4D	BRACKET, CLAMP 2	1	1	
3	663-43118-01-4D	HANDLE, TRANSOM CLAMP	2	2	
4	90243-04007	PIN	2	2	
5	6G0-43116-00	SCREW, TRANSOM CLAMP	2	2	
6	6F5-43114-00	PAD, TRANSOM CLAMP	2	2	
7	90109-06M12	BOLT	2	2	
8	6J8-43131-01	BOLT, CLAMP BRACKET	1	1	
9	6G5-43145-01	CAP, CLAMP BRACKET	2	2	
10	90185-22043	NUT, SELF-LOCKING	2	2	
11	90201-22M03	WASHER, PLATE	2	2	
12	90386-22M67	BUSH	2	2	
13	6J8-43113-01	PLATE, CLAMP BRACKET	1	1	
14	689-43191-00	SHAFT, STOPPER	1	1	
15	689-43192-01	KNOB, STOPPER	1	1	
16	91690-30016	PIN, SPRING	1	1	
17	93700-06M03	NIPPLE, GREASE	1	1	
18	663-45119-00	CAP, GREASE NIPPLE	1	1	AP
19	689-43160-00	TILT ROD ASSY	1	1	
20	689-43165-00	.PLATE, TILT LOCK	1	1	
21	91690-30008	.PIN, SPRING	1	1	
22	90502-10M07	SPRING, CONICAL	1	1	
23	90101-08339	BOLT	1	1	
24	90387-08M03	COLLAR	1	1	
25	92990-08600	WASHER, PLATE	1	1	
26	95380-08600	NUT	1	1	
27	689-43311-03-4D	BRACKET, SWIVEL 1	1	1	

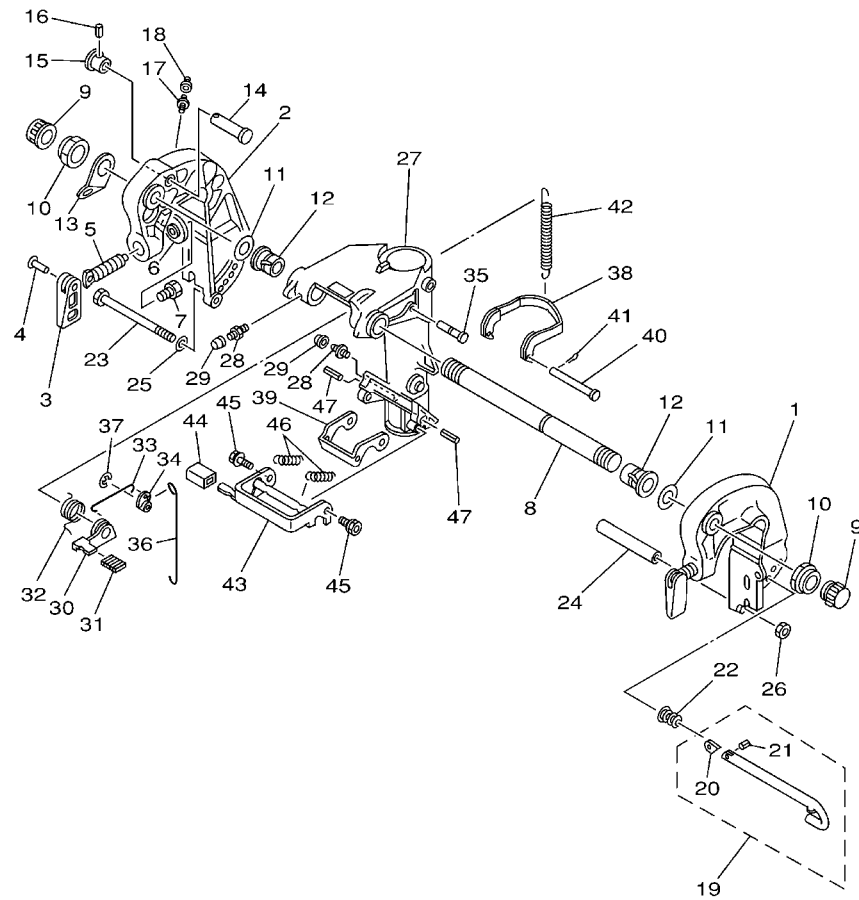

FWD
69T0200-1130

FIG. 14 BRACKET 1

REF. NO.	PART NO.	DESCRIPTION	69TA	6S85			REMARKS
28	93700-06M03	NIPPLE, GREASE	3	3			
29	663-45119-00	CAP, GREASE NIPPLE	3	3			AP
30	689-43631-00	LEVER, TILT	1	1			
31	689-43633-00	COVER, TILT LEVER	1	1			
32	689-43643-00	SPRING	1	1			
33	689-43616-00	ROD, TILT LOCK	1	1			
34	648-43642-00	LEVER, TILT 1	1	1			
35	90249-06M22	PIN	1	1			
36	648-43617-00	ROD, TILT LOCK	1	1			
37	99080-05600	CIRCLIP	1	1			
38	689-43614-01	PLATE, TILT LOCK	1	1			
39	648-43615-00	PLATE, TILT LOCK	1	1			
40	90240-05047	PIN, CLEVIS	1	1			
41	91490-16010	PIN, COTTER	1	1			
42	90506-30M27	SPRING, TENSION	1	1			
43	689-43681-01	LEVER, SHALLOW WATER DRIVE 1	1	1			
44	682-43318-01	COVER	1	1			
45	90109-06M18	BOLT	2	2			
46	90506-16M17	SPRING, TENSION	2	2			
47	91690-40035	PIN, SPRING	2	2			

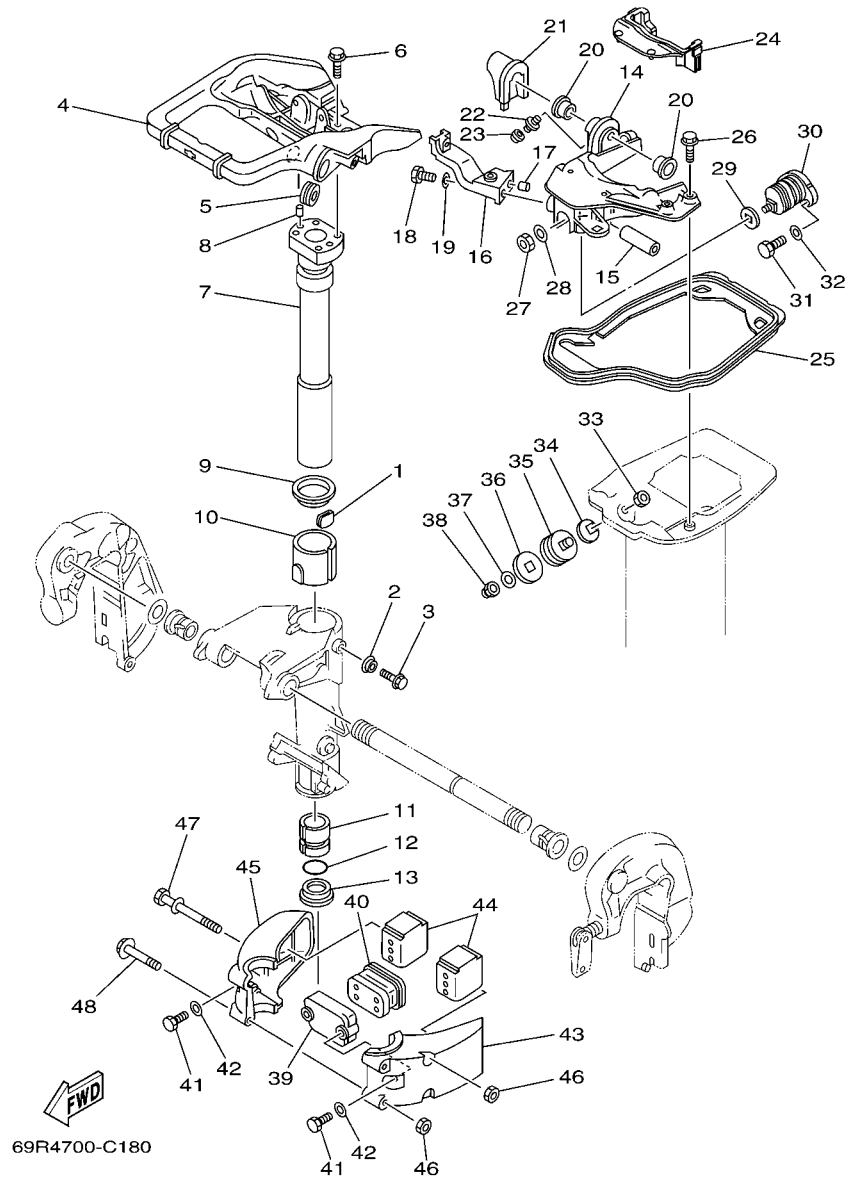

69R4700-C180

FIG. 15 BRACKET 2

REF. NO.	PART NO.	DESCRIPTION	69TA	6S85	REMARKS
1	648-42528-00	PLATE, FRICTION	1	1	
2	689-43373-01	SEAL, DAMPER	1	1	
3	90105-06M18	BOLT, FLANGE	1	1	
4	69P-42511-00-4D	BRACKET, STEERING	1	1	
5	90480-29045	GROMMET	1	1	
6	90105-06M07	BOLT, FLANGE	4	4	
7	689-42521-00-94	SHAFT, STEERING PIVOT	1	1	
8	93608-12063	PIN, DOWEL	2	2	
9	90209-47016	WASHER	1	1	
10	90386-47M22	BUSH	1	1	
11	90386-38090	BUSH	1	1	
12	93210-37160	O-RING	1	1	
13	90386-38022	BUSH	1	1	
14	69P-44518-00-94	BRACKET COMP.	1	1	
15	90387-10M39	COLLAR	1	1	
16	648-44519-00-94	BRACKET	1	1	
17	93606-12019	PIN, DOWEL	1	1	
18	97095-06018	BOLT	1	1	
19	92995-06600	WASHER	1	1	
20	90381-12M01	BUSH, SOLID	2	2	
21	689-42718-00	RUBBER, SEAL 3	1	1	
22	93700-06M03	NIPPLE, GREASE	1	1	
23	663-45119-00	CAP, GREASE NIPPLE	1	1	AP
24	69P-42717-00	RUBBER, SEAL 2	1	1	
25	69P-42716-00	RUBBER, SEAL 1	1	1	
26	90105-06M08	BOLT, FLANGE	4	4	
27	90170-10M42	NUT	1	1	

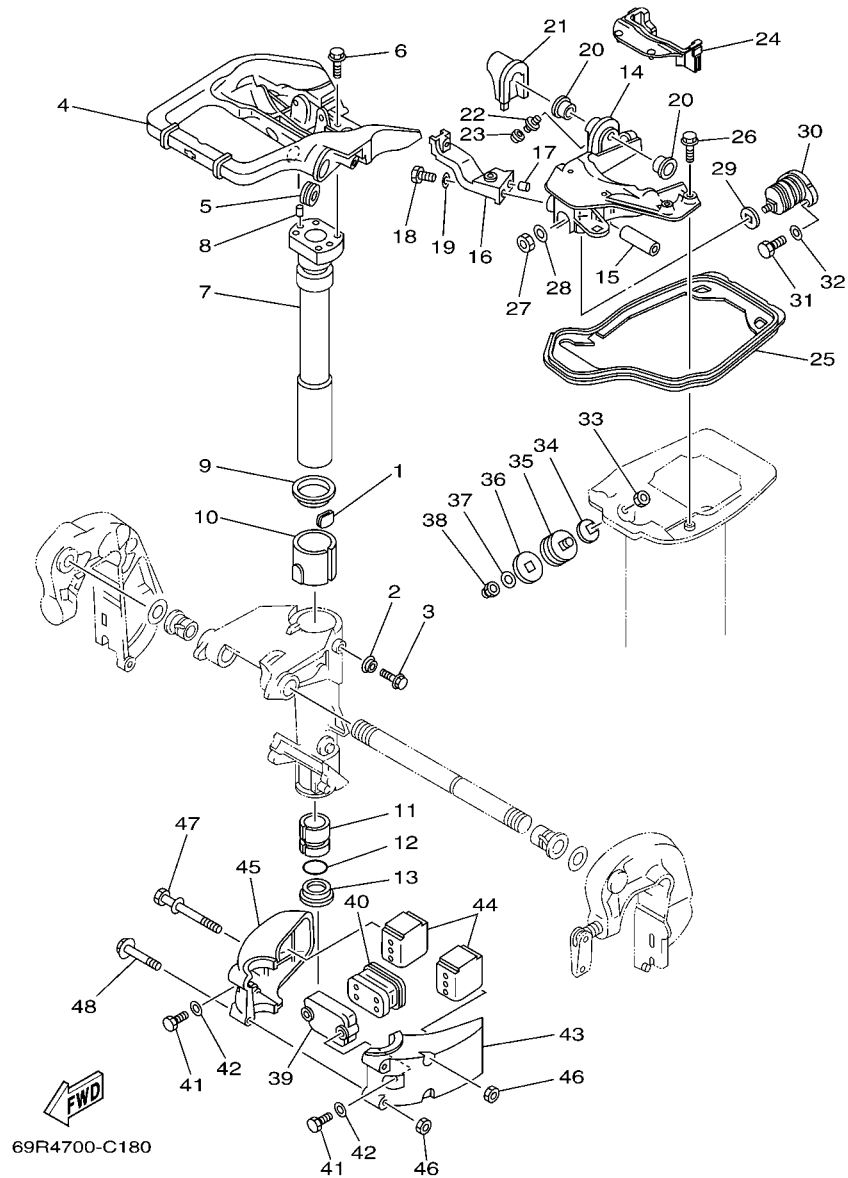

FIG. 15 BRACKET 2

REF. NO.	PART NO.	DESCRIPTION	69TA	6S85	REMARKS
28	92990-10200	WASHER, PLAIN	1	1	
29	648-44591-A0	GASKET	1	1	
30	689-44516-00	MOUNT DAMPER, UPPER FRONT	1	1	
31	97095-06020	BOLT	2	2	
32	92995-06600	WASHER	2	2	
33	90170-10M42	NUT	2	2	
34	648-44591-A0	GASKET	2	2	
35	664-44514-00-94	MOUNT DAMPER, UPPER SIDE	2	2	
36	664-44591-A0	GASKET	2	2	
37	92990-10200	WASHER, PLAIN	2	2	
38	90176-10M01	NUT, CROWN	2	2	
39	689-44553-00-94	COVER, LOWER MOUNT	1	1	
40	689-44557-00	MOUNT DAMPER, LOWER FRONT	1	1	
41	97075-08025	BOLT	2	2	
42	92995-08600	WASHER	2	2	
43	689-44551-01-4D	HOUSING, LOWER MOUNT RUBBER	1	1	
44	689-44555-00	MOUNT DAMPER, LOWER SIDE	2	2	
45	689-44552-01-4D	HOUSING, LOWER MOUNT RUBBER	1	1	
46	95380-08600	NUT	4	4	
47	90119-08M03	BOLT, WITH WASHER	2	2	
48	97595-08565	BOLT, WITH WASHER	2	2	

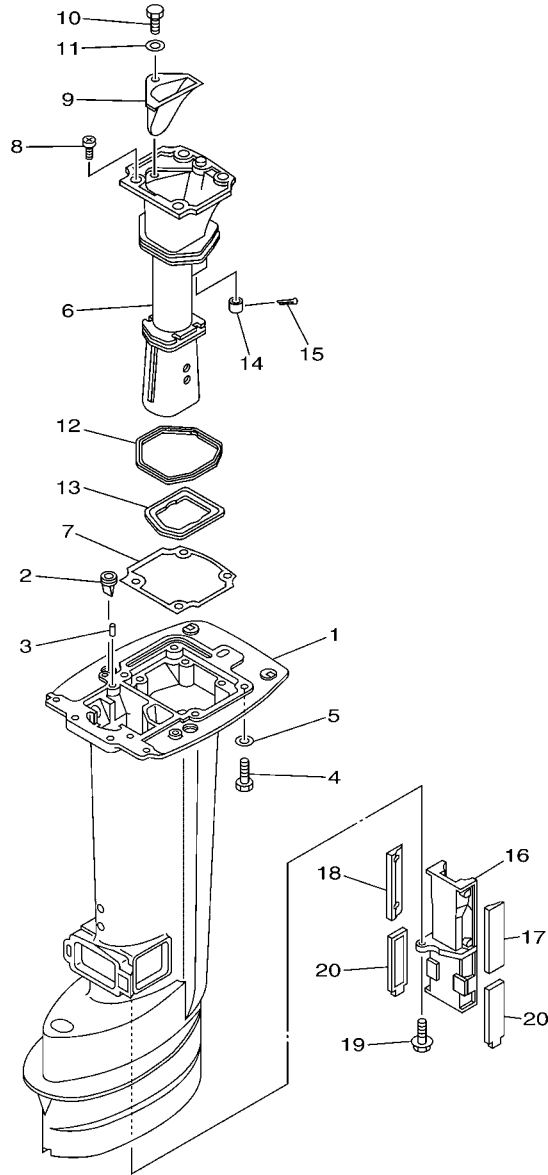

FIG. 16 UPPER CASING

REF. NO.	PART NO.	DESCRIPTION	69TA	6S85		REMARKS
1	69P-45111-10-4D	CASING, UPPER	1	1		L(21.6")
2	65W-42717-00	RUBBER, SEAL 2	2	2		
3	93606-12019	PIN, DOWEL	2	2		
4	97075-08030	BOLT	6	6		
5	92995-08600	WASHER	6	6		
6	69P-41131-01-5B	MANIFOLD, EXT. 1	1	1		
7	69P-41134-A0	GASKET, EXHAUST MANIFOLD	1	1		
8	97880-06016	SCREW, PAN HEAD	4	4		
9	69P-41137-00-5B	GUIDE, EXHAUST	1	1		
10	97095-08020	BOLT	1	1		
11	92995-08600	WASHER	1	1		
12	69P-41138-00	SEAL, EXT. 1	1	1		
13	69P-41139-00	SEAL, EXT. 2	1	1		
14	6A8-41135-00	GASKET, EXHAUST MANIFOLD	1	1		
15	91490-30025	PIN, COTTER	1	1		
16	69P-47467-10-5B	PLATE, GUIDE	1	1		L(21.6")
17	69P-45127-00	SEAL	1	1		
18	69P-45128-00	SEAL 2	1	1		
19	90119-06024	BOLT, WITH WASHER	1	1		
20	69P-45159-00	DAMPER	2	2		L(21.6")

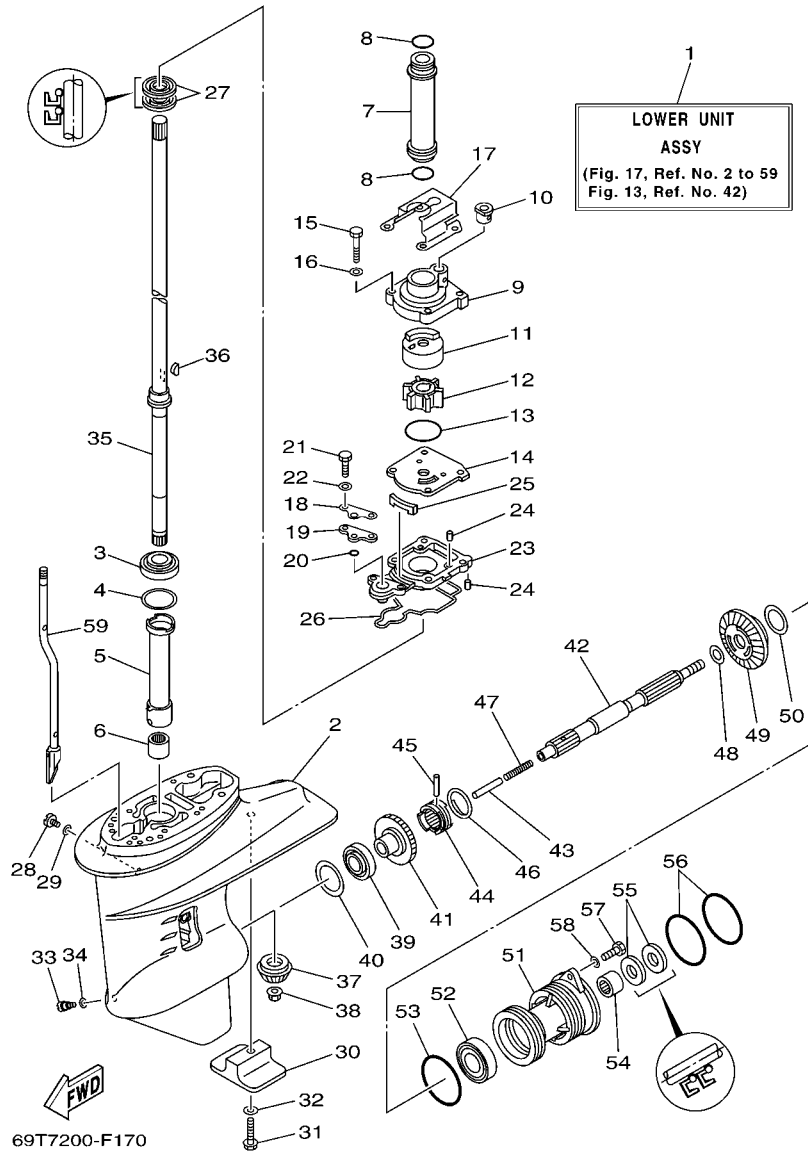

FIG. 17 LOWER CASING & DRIVE 1

REF. NO.	PART NO.	DESCRIPTION	69TA	6S85	REMARKS
1	69P-45300-11-4D	LOWER UNIT ASSY	1	1	L(21.6")
2	61N-45311-02-4D	CASING, LOWER	1	1	
3	93332-000W5	BEARING	1	1	
4	61N-45587-00	SHIM (T:0.7MM)	1	1	UR
	61N-45587-10	SHIM (T:1.0MM)	1	1	UR
	61N-45587-20	SHIM (T:1.1MM)	1	1	UR
	61N-45587-30	SHIM (T:1.2MM)	1	1	UR
	61N-45587-40	SHIM (T:1.3MM)	1	1	UR
	61N-45587-50	SHIM (T:1.4MM)	1	1	UR
	61N-45587-60	SHIM (T:1.5MM)	1	1	UR
	61N-45587-70	SHIM (T:1.6MM)	1	1	UR
5	61N-45536-00	SLEEVE, DRIVE SHAFT	1	1	
6	93315-220V7	BEARING	1	1	
7	61N-44362-10	TUBE, WATER	1	1	L(21.6")
8	93210-26130	O-RING	2	2	L(21.6")
9	69P-44311-00	HOUSING, WATER PUMP	1	1	
10	6L2-44367-00	DAMPER, WATER SEAL	1	1	
11	69P-44322-40	INSERT, CARTRIDGE	1	1	FOR CHROMATE
12	6H4-44352-02	IMPELLER	1	1	
13	93210-45161	O-RING	1	1	
14	61N-44323-40	OUTER PLATE, CARTRIDGE	1	1	FOR CHROMATE
15	97095-06040	BOLT	4	4	
16	92995-06600	WASHER	4	4	
17	65W-44328-11	PLATE	1	1	L(21.6")
18	61N-44176-00	BRACKET	1	1	
19	61N-45321-00	PLATE	1	1	
20	93210-06ME6	O-RING	1	1	

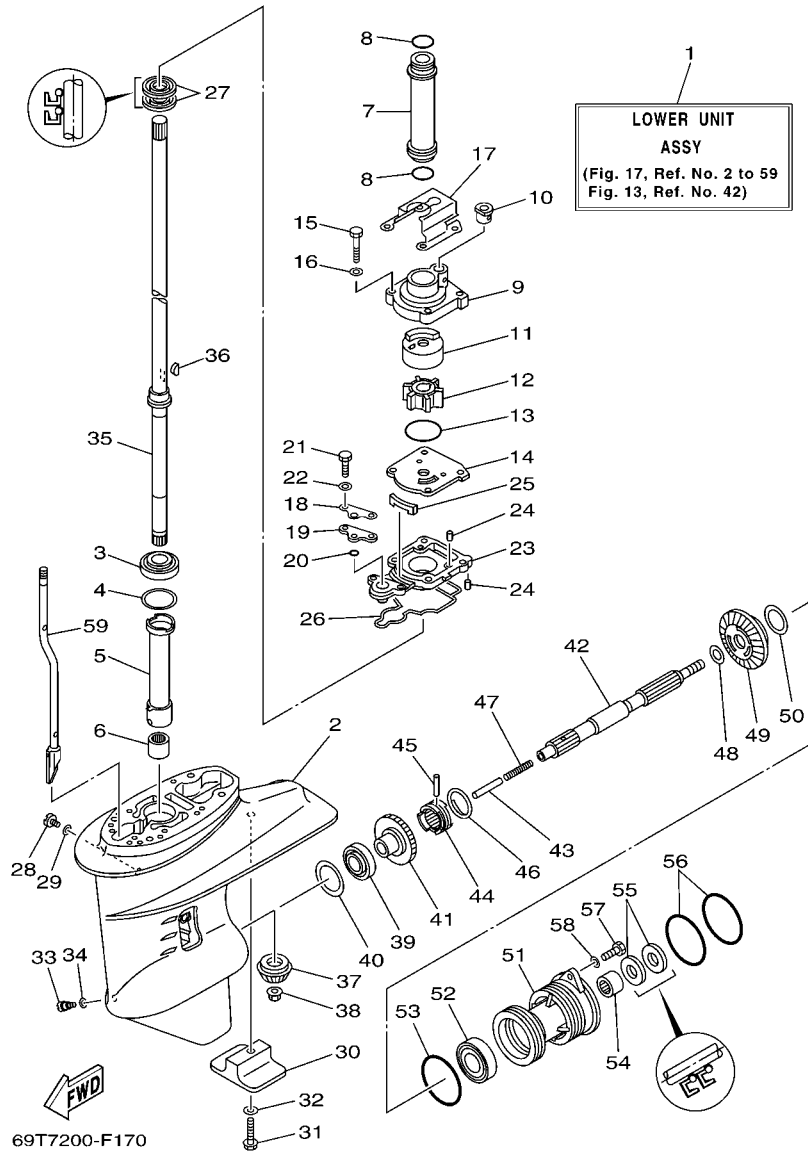

FIG. 17 LOWER CASING & DRIVE 1

REF. NO.	PART NO.	DESCRIPTION	69TA	6S85	REMARKS
21	97095-06025	BOLT	2	2	
22	92995-06600	WASHER	2	2	
23	61N-45331-00-5B	HOUSING, BEARING	1	1	
24	93604-10M03	PIN, DOWEL	3	3	
25	61N-45127-00	SEAL	1	1	
26	61N-45315-00	PACKING, LOWER CASING	1	1	
27	93101-22067	OIL SEAL	2	2	
28	90340-08002	PLUG, STRAIGHT SCREW	1	1	
29	90430-08020	GASKET	1	1	
30	61N-45251-01	ANODE	1	1	
31	95895-06035	BOLT, FLANGE	1	1	
32	92990-06300	WASHER, INTERNAL TOOTH	1	1	
33	688-45341-10	PLUG, DRAIN	1	1	
34	90430-08020	GASKET	1	1	
35	61N-45510-10	DRIVE SHAFT ASSY	1	1	L(21.6")
36	90280-03M03	KEY, WOODRUFF	1	1	
37	61N-45551-00	PINION (13T)	1	1	
38	90179-10M14	NUT	1	1	
39	93332-00005	BEARING	1	1	
40	6L2-45567-00	SHIM (T:1.0MM)	1	1	UR
	6L2-45567-10	SHIM (T:1.1MM)	1	1	UR
	6L2-45567-20	SHIM (T:1.2MM)	1	1	UR
	6L2-45567-30	SHIM (T:1.3MM)	1	1	UR
	6L2-45567-40	SHIM (T:1.4MM)	1	1	UR
41	61N-45560-10	GEAR 1 (27T)	1	1	
42	65W-45611-00	SHAFT, PROPELLER	1	1	
43	648-45635-00	PLUNGER, SHIFT	1	1	

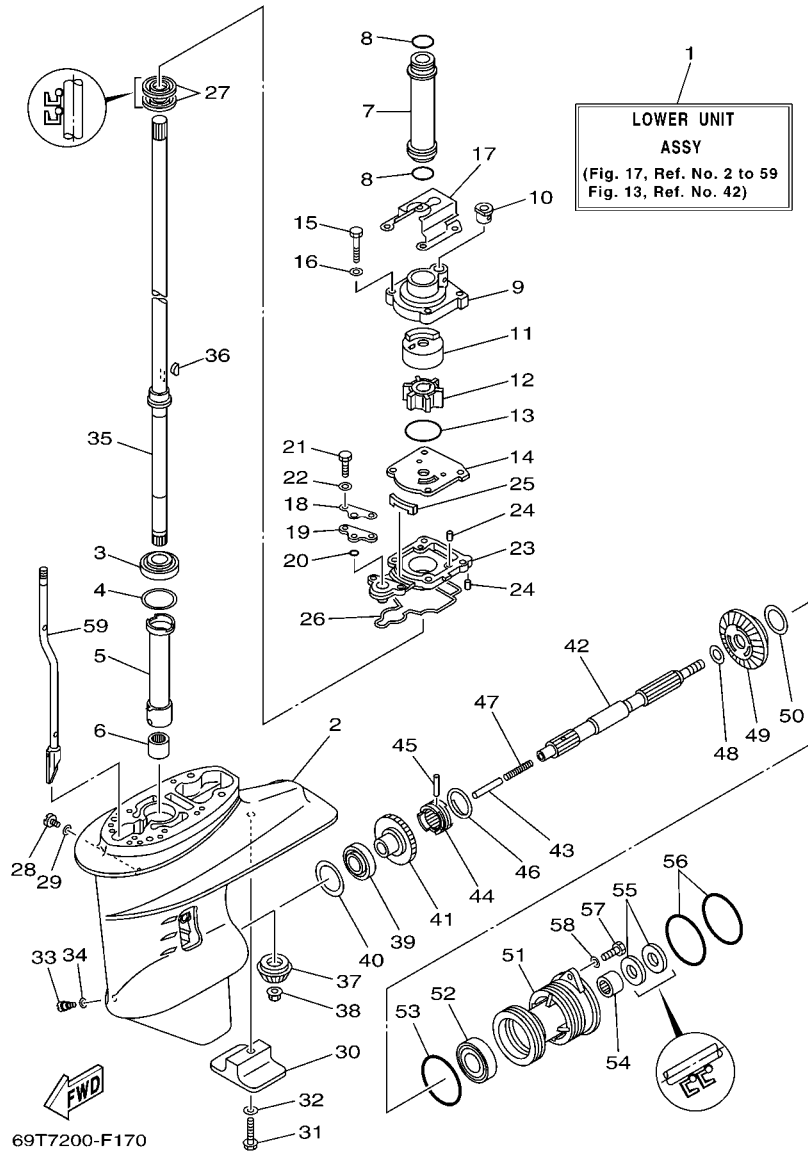
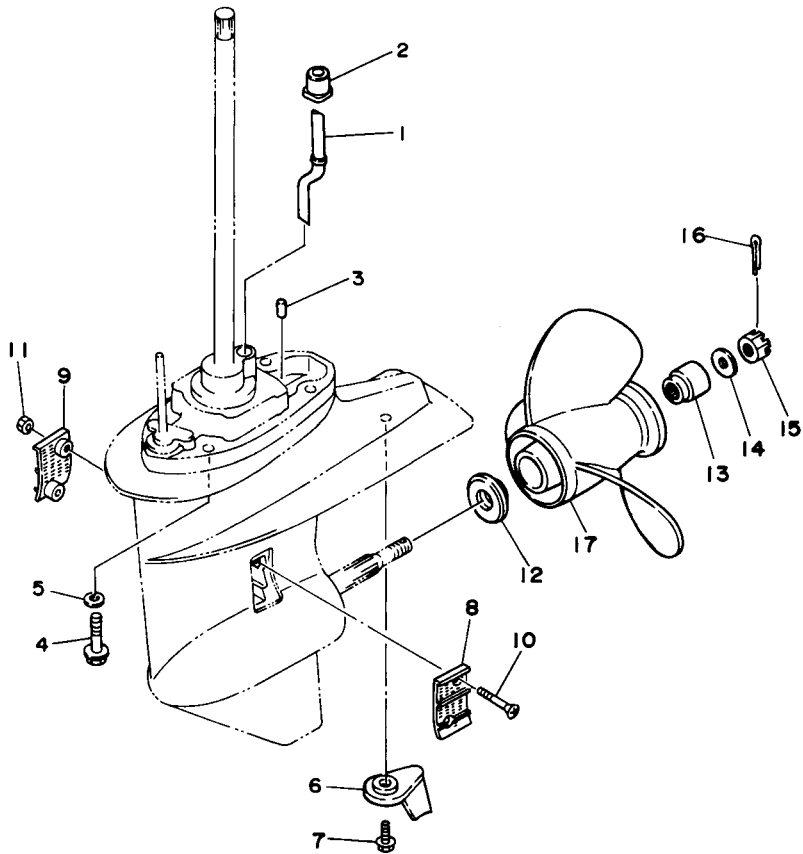

FIG. 17 LOWER CASING & DRIVE 1

REF. NO.	PART NO.	DESCRIPTION	69TA	6S85	REMARKS
44	664-45631-02	CLUTCH, DOG	1	1	
45	90250-05010	PIN, STRAIGHT	1	1	
46	648-45633-00	RING, CROSS PIN	1	1	
47	90501-10065	SPRING, COMPRESSION	1	1	
48	90201-20417	WASHER, PLATE	1	1	
49	61N-45571-00	GEAR 2 (27T)	1	1	
50	6L2-45577-00	SHIM (T:1.0MM)	1	1	UR
	6L2-45577-10	SHIM (T:1.1MM)	1	1	UR
	6L2-45577-20	SHIM (T:1.2MM)	1	1	UR
	6L2-45577-30	SHIM (T:1.3MM)	1	1	UR
51	61N-45361-01-4D	CAP, LOWER CASING	1	1	
52	93306-00612	BEARING	1	1	
53	93210-64ME7	O-RING	1	1	
54	93315-22004	BEARING	1	1	
55	93101-20M07	OIL SEAL	2	2	
56	93210-65M50	O-RING	2	2	
57	97075-06020	BOLT	2	2	
58	92995-06600	WASHER	2	2	
59	61N-44150-10	SHIFT CAM ASSY	1	1	L(21.6")



61R0010-4180

FIG. 18 LOWER CASING & DRIVE 2

REF. NO.	PART NO.	DESCRIPTION	69TA	6S85	REMARKS
1	61N-44361-10	TUBE, WATER	1	1	L(21.6")
2	689-44366-00	DAMPER, WATER SEAL	1	1	
3	93606-11M24	PIN, DOWEL	2	2	
4	90105-10M12	BOLT, FLANGE	4	4	
5	92995-10600	WASHER	4	4	
6	61N-45371-00	TAB-TRIM	1	1	
7	90119-06M48	BOLT, WITH WASHER	1	1	
8	6L2-45214-00	COVER, WATER INLET 1	1	1	
9	6L2-45215-00	COVER, WATER INLET 2	1	1	
10	90151-05M05	SCREW, COUNTERSUNK	2	2	
11	90185-05002	NUT, NYLON	2	2	
12	6L2-45987-01	SPACER	1	1	
13	689-45997-00	SPACER	1	1	
14	92990-14200	WASHER, PLAIN	1	1	
15	90171-14013	NUT, CASTLE	1	1	
16	91490-30022	PIN, COTTER	1	1	
17	664-45941-01-EL	PROPELLER (3X9-7/8"X9"-F)	1	1	UR
	664-45943-01-EL	PROPELLER (3X9-7/8"X8"-F)	1	1	UR
	664-45945-00-EL	PROPELLER (3X9-7/8"X10-1/2"-F)	1	1	UR
	664-45947-01-EL	PROPELLER (3X9-7/8"X11-1/4"-F)	1	1	UR
	664-45949-02-EL	PROPELLER (3X9-7/8"X13"-F)	1	1	UR
	664-45952-00-EL	PROPELLER (3X9-7/8"X14"-F)	1	1	UR
	664-45954-00-EL	PROPELLER (3X9-7/8"X12"-F)	1	1	UR
	62C-45941-00-EL	PROPELLER (3X9-7/8"X10"-F)	1	1	UR

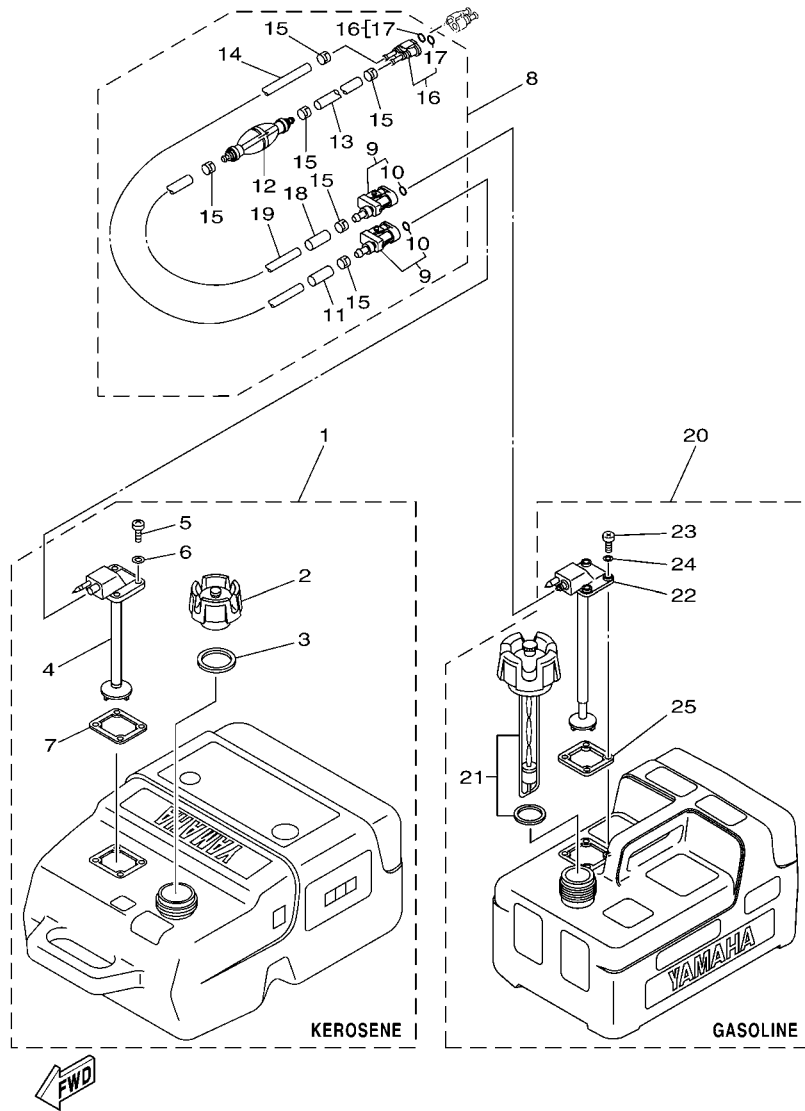

69T5200-D190

FIG. 19 FUEL TANK

REF. NO.	PART NO.	DESCRIPTION	69TA	6S85		REMARKS
1	6YK-24201-21	FUEL TANK ASSY (25L,KEROSENE)	1			AP KEROSENE
2	6YK-24610-10	.CAP ASSY	1			WITHOUT INDICATOR
3	6YL-24641-00	.GASKET, CAP 1	1			
4	6YK-24260-01	.FUEL METER ASSY	1			
5	90157-05M16	.SCREW, PAN HEAD	4			
6	6YL-24329-00	.SEAL	4			
7	6YL-24268-01	.GASKET, FUEL METER	1			
8	6YK-24306-04	FUEL PIPE COMP. 1	1			AP
9	6Y1-24305-06	.FUEL PIPE JOINT COMP. 2	2			
10	93210-08287	..O-RING	1			
11	6Y1-24397-10	.COLLAR (KEROSENE)	1			
12	61J-24360-00	.PRIMER PUMP ASSY	1			
13	90445-11M05	.HOSE (L850)	1			
14	90445-11M81	.HOSE (L3000)	1			
15	650-24351-01	.BAND 1	6			
16	680-24305-01	.FUEL PIPE JOINT COMP. 2	1			
17	93210-08287	..O-RING	2			
18	6Y1-24397-00	.COLLAR (GASOLINE)	1			
19	90445-11M06	.HOSE (L2050)	1			
20	6YL-24201-05	FUEL TANK ASSY (12L)	1			AP GASOLINE
21	6YL-24610-01	.CAP ASSY	1			
22	6YL-24260-01	.FUEL METER ASSY	1			
23	90157-05M16	.SCREW, PAN HEAD	4			
24	6YL-24329-00	.SEAL	4			
25	6YL-24268-01	.GASKET, FUEL METER	1			

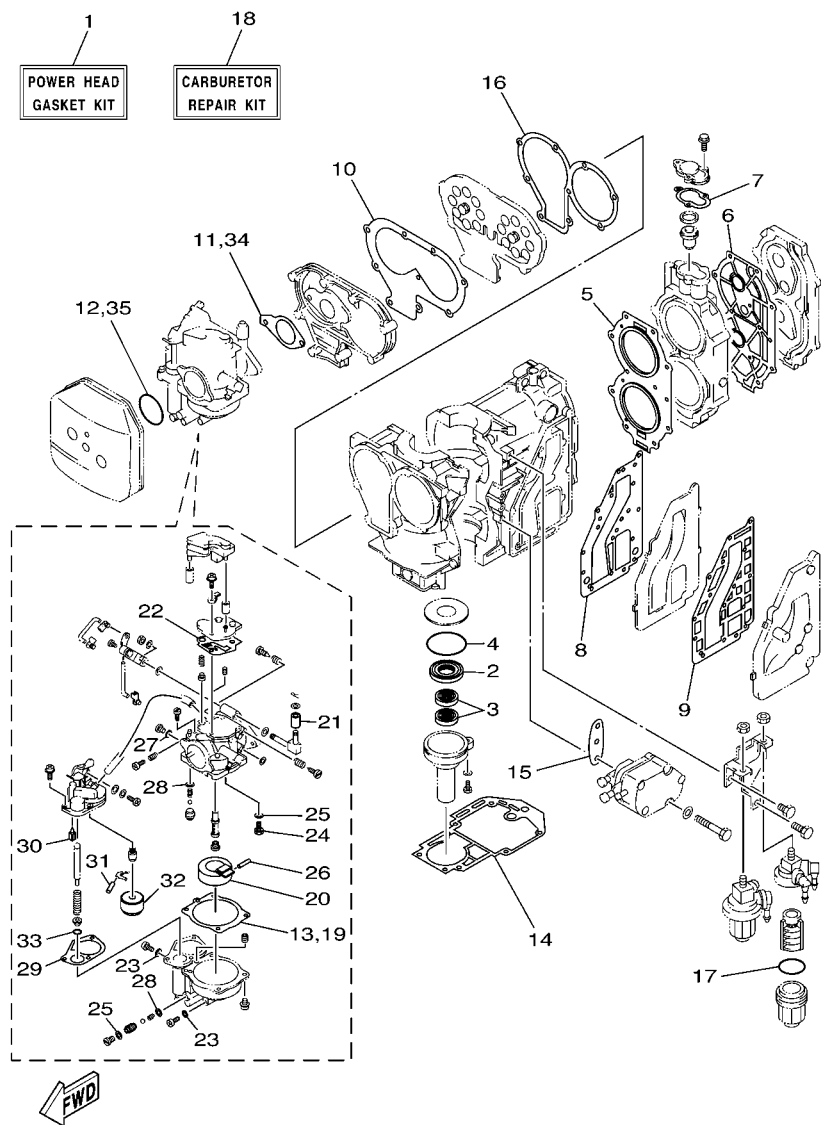

69T4200-C200

FIG. 20 REPAIR KIT 1

REF. NO.	PART NO.	DESCRIPTION	69TA	6S85		REMARKS
1	69T-W0001-00	POWER HEAD GASKET KIT	1	1		
2	93102-25008	.OIL SEAL	1	1		
3	93101-16001	.OIL SEAL	2	2		
4	93210-58M21	.O-RING	1	1		
5	61N-11181-A2	.GASKET, CYLINDER HEAD 1	1	1		
6	61T-11193-A1	.GASKET, HEAD COVER 1	1	1		
7	655-12414-A1	.GASKET, COVER	1	1		
8	6K8-41122-A1	.GASKET, EXHAUST INNER COVER	1	1		
9	6K8-41124-A1	.GASKET, EXHAUST OUTER COVER	1	1		
10	648-13645-A0	.GASKET, MANIFOLD 1	1	1		
11	648-14198-A0	.GASKET	1	1		
12	93210-39M89	.O-RING	1	1		
13	6A4-14384-00	.GASKET, FLOAT CHAMBER	1	1		
14	689-45113-A1	.GASKET, UPPER CASING	1	1		
15	650-24431-A0	.GASKET, FUEL PUMP 1	1	1		
16	648-13621-A1	.GASKET, VALVE SEAT	1	1		
17	93210-32738	.O-RING	2	2		
18	69T-W0093-00	CARBURETOR REPAIR KIT	1	1		
19	6A4-14384-00	.GASKET, FLOAT CHAMBER	1	1		
20	648-14385-00	.FLOAT	1	1		
21	69T-41231-00	.COLLAR, GUIDE PIN	1	1		
22	6A4-14398-01	.GASKET	1	1		
23	6L2-14398-00	.GASKET	2	2		
24	6J0-14390-14	.NEEDLE VALVE ASSY	1	1		
25	367-14195-00	.GASKET	2	2		
26	689-14386-00	.PIN, FLOAT	1	1		
27	652-14397-00	.O-RING	1	1		

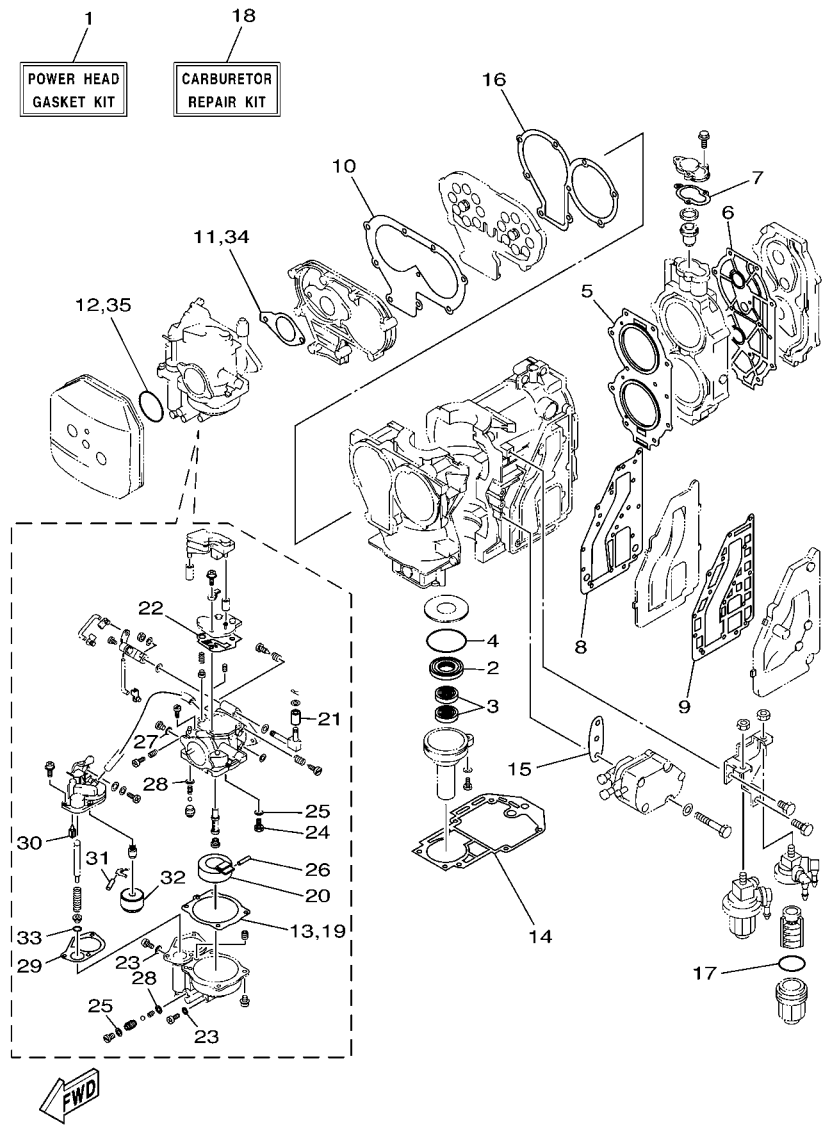

69T4200-C200

FIG. 20 REPAIR KIT 1

REF. NO.	PART NO.	DESCRIPTION	69TA	6S85	REMARKS
28	6F5-14372-01	.SEAT, PACKING	2	2	
29	6J0-14384-00	.GASKET, FLOAT CHAMBER	1	1	
30	62C-14392-00	.VALVE, NEEDLE	1	1	
31	6A4-14386-00	.PIN, FLOAT	1	1	
32	652-14385-00	.FLOAT	1	1	
33	652-14147-00	.O-RING	1	1	
34	648-14198-A0	.GASKET	1	1	
35	93210-39M89	.O-RING	1	1	

FIG. 21 REPAIR KIT 2

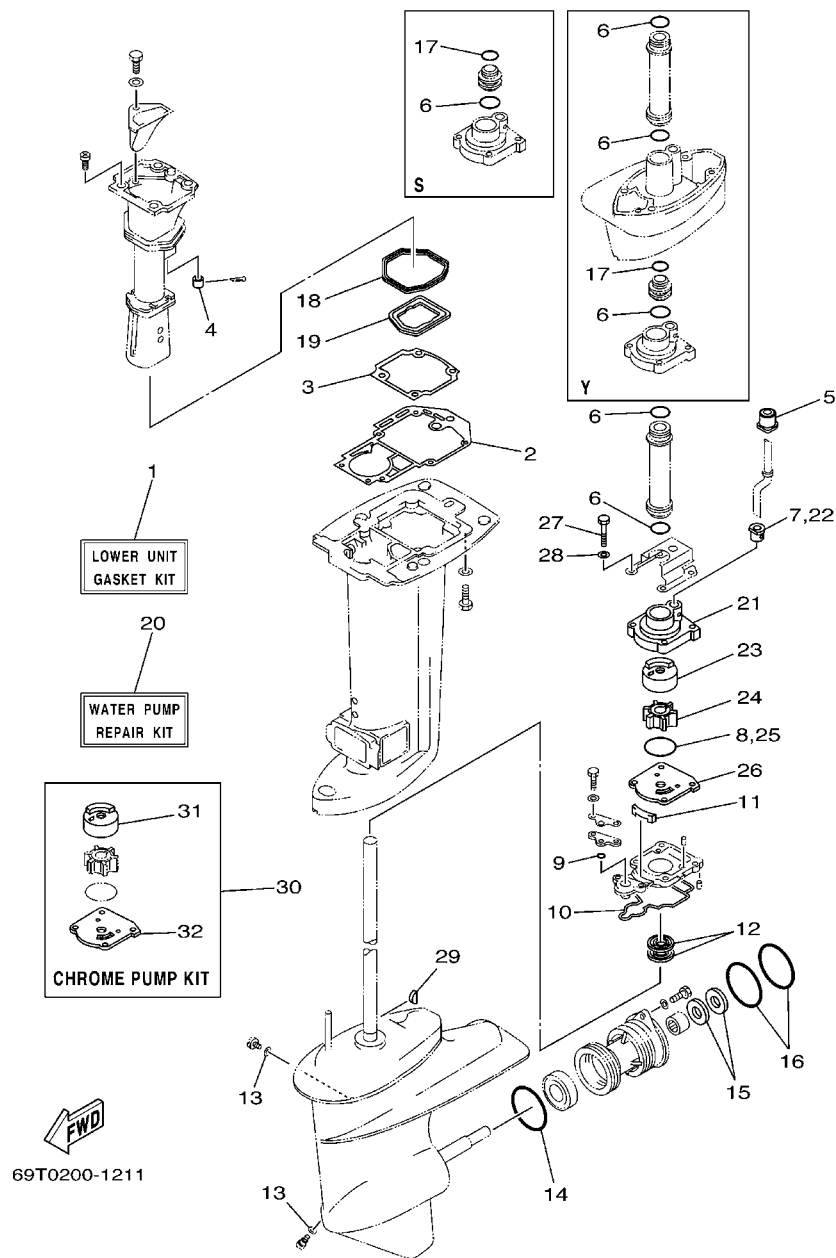

REF. NO.	PART NO.	DESCRIPTION	69TA	6S85	REMARKS
1	69P-W0001-20	LOWER UNIT GASKET KIT	1	1	
2	689-45113-A1	.GASKET, UPPER CASING	1	1	
3	69P-41134-A0	.GASKET, EXHAUST MANIFOLD	1	1	
4	6A8-41135-00	.GASKET, EXHAUST MANIFOLD	1	1	
5	689-44366-00	.DAMPER, WATER SEAL	1	1	
6	93210-26130	.O-RING	3	3	UN
7	6L2-44367-00	.DAMPER, WATER SEAL	1	1	
8	93210-45161	.O-RING	1	1	
9	93210-06ME6	.O-RING	1	1	
10	61N-45315-00	.PACKING, LOWER CASING	1	1	
11	61N-45127-00	.SEAL	1	1	
12	93101-22067	.OIL SEAL	2	2	
13	90430-08020	.GASKET	2	2	
14	93210-64ME7	.O-RING	1	1	
15	93101-20M07	.OIL SEAL	2	2	
16	93210-65M50	.O-RING	2	2	
17	93210-22164	.O-RING	1	1	S(16.7"),Y(23.5")
18	69P-41138-00	.SEAL, EXT. 1	1	1	
19	69P-41139-00	.SEAL, EXT. 2	1	1	
20	69P-W0078-00	WATER PUMP REPAIR KIT	1	1	
21	69P-44311-00	.HOUSING, WATER PUMP	1	1	
22	6L2-44367-00	.DAMPER, WATER SEAL	1	1	
23	69P-44322-00	.INSERT, CARTRIDGE	1	1	
24	6H4-44352-02	.IMPELLER	1	1	
25	93210-45161	.O-RING	1	1	
26	61N-44323-00	.OUTER PLATE, CARTRIDGE	1	1	
27	97095-06040	.BOLT	4	4	

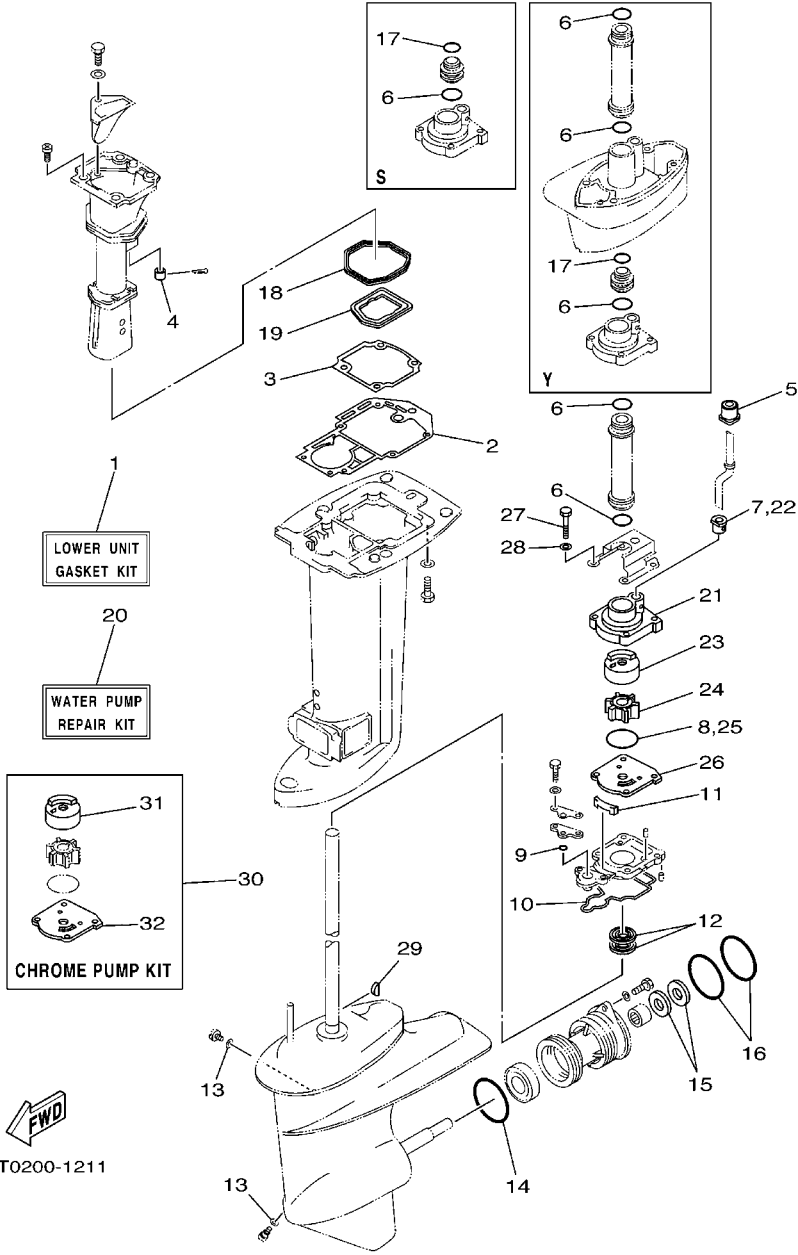

69T0200-1211

FIG. 21 REPAIR KIT 2

REF. NO.	PART NO.	DESCRIPTION	69TA	6S85				REMARKS
28	92995-06600	.WASHER	4	4				
29	90280-03M03	.KEY, WOODRUFF	1	1				
30	69P-W0078-0A	CHROME PUMP KIT	1	1				
31	69P-44322-40	.INSERT, CARTRIDGE	1	1				
32	61N-44323-40	.OUTER PLATE, CARTRIDGE	1	1				
<hr style="border-top: 1px dashed black;"/>								
<hr style="border-top: 1px dashed black;"/>								
<hr style="border-top: 1px dashed black;"/>								
<hr style="border-top: 1px dashed black;"/>								
<hr style="border-top: 1px dashed black;"/>								
<hr style="border-top: 1px dashed black;"/>								
<hr style="border-top: 1px dashed black;"/>								
<hr style="border-top: 1px dashed black;"/>								

NUMERICAL INDEX

PART NO.	REF. NO.	PART NO.	REF. NO.	PART NO.	REF. NO.	PART NO.	REF. NO.	PART NO.	REF. NO.	PART NO.	REF. NO.
62C-11111-00-1S	2 - 19	367-14195-00	20 - 25	648-14385-00	5 - 5	6F5-15779-02	8 - 17	61N-26326-00	11 - 18	6F6-42177-A0	12 - 12
61N-11181-A2	2 - 21	69T-14196-00	5 - 65		20 - 20	6A0-15789-00	8 - 22	6E0-28193-00-94	6 - 45	69P-42511-00-4D	15 - 4
	20 - 5	648-14198-A0	4 - 10	652-14385-00	5 - 40	6YL-24201-05	19 - 20	626-28193-01-94	6 - 45	689-42521-00-94	15 - 7
61N-11191-01-1S	2 - 22		20 - 11		20 - 32	6YK-24201-21	19 - 1	6K8-41121-00-1S	2 - 32	647-42523-00	11 - 17
61T-11193-A1	2 - 23		20 - 34	689-14386-00	5 - 27	6YK-24260-01	19 - 4	6K8-41122-A1	2 - 33	648-42528-00	15 - 1
	20 - 6	646-14212-01	5 - 21		20 - 26	6YL-24260-01	19 - 22		20 - 8	69T-42610-K0-4D	1 - 1
689-11325-00	2 - 17	6A4-14225-00	5 - 60	6A4-14386-00	5 - 39	6YL-24268-01	19 - 7	61N-41123-01-1S	2 - 34	69P-42613-00-4D	1 - 7
6J8-11325-00	2 - 12	69T-14301-00	5 - 1		20 - 31		19 - 25	6K8-41124-A1	2 - 37	6G0-42615-00	1 - 2
6H3-11327-00-1S	2 - 13	69T-14301-20	5 - 1	6J0-14387-00	5 - 38	680-24304-01	6 - 1		20 - 9	61N-42628-00	1 - 10
6H3-11328-00	2 - 14	69T-14310-00	5 - 19	6J0-14390-14	5 - 25	680-24305-01	7 - 6	69P-41131-01-5B	16 - 6	689-42647-00	1 - 3
676-11372-00	2 - 20	664-14321-01	5 - 20		20 - 24		19 - 16	69P-41134-A0	16 - 7	6G0-42651-02	1 - 5
	2 - 35	647-14323-00	5 - 54	62C-14392-00	5 - 37	6Y1-24305-06	19 - 9		21 - 3	69P-42677-H0	1 - 12
69T-11400-00	3 - 1	6J0-14323-00	5 - 62		20 - 30	6Y3-24306-04	7 - 1	6A8-41135-00	16 - 14	62C-42678-K0	1 - 13
69P-11412-00	3 - 2	6A0-14325-00	6 - 30	6A4-14394-00	5 - 29	6YK-24306-04	19 - 8		21 - 4	6A4-42711-05-4D	11 - 1
61N-11422-00	3 - 3	62C-14326-00	5 - 61	652-14397-00	5 - 28	6G0-24311-00	6 - 17	69P-41137-00-5B	16 - 9	664-42715-00	13 - 20
61N-11432-00	3 - 4	677-14327-01	5 - 45		20 - 27	62C-24312-00	6 - 41	69P-41138-00	16 - 12	69P-42716-00	15 - 25
61N-11442-00	3 - 5	6J0-14329-01	5 - 47	6L2-14398-00	5 - 13	6A4-24314-00	6 - 16		21 - 18	65W-42717-00	16 - 2
61N-11515-00	3 - 10	6A4-14332-00	5 - 35		20 - 23	6A4-24329-00	6 - 4	69P-41139-00	16 - 13	69P-42717-00	15 - 24
61N-11603-00	3 - 19	6F5-14332-01	5 - 31	6A4-14398-01	5 - 11	6YL-24329-00	19 - 6		21 - 19	689-42718-00	15 - 21
61N-11604-00	3 - 19	656-14335-00	5 - 22		20 - 22		19 - 24	69T-41213-00	13 - 17	682-42724-00	11 - 15
61N-11605-00	3 - 19	69T-14337-00	5 - 67	62C-14435-00	4 - 19	650-24351-01	7 - 5	69T-41216-00	5 - 8	689-42725-01	11 - 16
61N-11631-00-95	3 - 18	6A4-14339-01	5 - 51	62C-14440-01	4 - 11		19 - 15	69T-41231-00	5 - 6	6E7-42791-00	11 - 23
689-11633-00	3 - 20	6J0-14341-00	5 - 4	689-14497-00	13 - 1	61J-24360-00	7 - 3		20 - 21	6AH-42794-40	11 - 24
688-11634-00	3 - 22	6J0-14342-24	5 - 41	62Y-14597-00	5 - 15		19 - 12	662-41237-01	13 - 6	6G0-42796-00	11 - 5
61N-11635-00	3 - 18	69T-14342-25	5 - 63	69T-14987-00	5 - 66	6Y1-24397-00	19 - 18		13 - 11	689-42815-00	11 - 10
61N-11636-00	3 - 18	648-14343-70	5 - 3	69P-15100-00-1S	2 - 2	6Y1-24397-10	19 - 11	679-41241-01	13 - 8	689-42816-00	11 - 13
689-11651-00	3 - 12	648-14343-78	5 - 3	689-15396-01-5B	2 - 6	62C-24410-00	6 - 20	6J0-41252-00	4 - 23	689-43111-03-4D	14 - 1
689-11681-01	3 - 13	6J0-14344-43	5 - 24	61N-15711-10	8 - 2	663-24411-00	6 - 32	62C-41256-00	4 - 24	689-43112-02-4D	14 - 2
6F5-12411-03	2 - 26	6A4-14346-01	5 - 10	6F5-15713-01	8 - 5	692-24411-00	6 - 28	6F5-41262-01	5 - 44	6J8-43113-01	14 - 13
6E5-12412-00	2 - 27	6J0-14348-00	5 - 18	6G0-15714-01	8 - 3	6A0-24412-02	6 - 37	661-41262-02	4 - 25	6F5-43114-00	14 - 6
655-12413-01-1S	2 - 29	6J0-14353-25	5 - 56	61N-15715-00	8 - 6	6A0-24413-00	6 - 34		5 - 48	6G0-43116-00	14 - 5
655-12414-A1	2 - 30	69T-14353-40	5 - 64	6F5-15716-01	8 - 8	6A0-24421-01	6 - 29	682-41271-00	4 - 20	663-43118-01-4D	14 - 3
	20 - 7	6A4-14355-00	5 - 33	6F5-15723-01	8 - 34	650-24431-A0	6 - 38	689-41273-00	4 - 21	6J8-43131-01	14 - 8
6B8-13437-00	1 - 14	6A4-14355-10	5 - 34	6F5-15726-01	8 - 11		20 - 15	6J8-41274-00	4 - 22	6G5-43145-01	14 - 9
6J0-13610-00	4 - 1	6L2-14357-00	5 - 55	61N-15734-00	8 - 7	652-24432-00	6 - 26	676-41611-00	9 - 17	689-43160-00	14 - 19
648-13621-A1	4 - 3	69T-14367-00	5 - 7	6F5-15739-00	8 - 16	648-24434-01	6 - 27	689-41612-01	9 - 21	689-43165-00	14 - 20
	20 - 16	6A4-14369-01	5 - 32	6F5-15741-01	8 - 4	648-24435-02	6 - 33	676-41613-00	9 - 18	689-43191-00	14 - 14
648-13641-02-1S	4 - 4	69T-14370-00	5 - 50	656-15748-00	8 - 37	62C-24461-00	6 - 22	62C-41615-00	10 - 1	689-43192-01	14 - 15
648-13645-A0	4 - 5	62C-14371-00	5 - 23	656-15749-00	8 - 41	652-24461-00	6 - 21	61N-41631-00-94	13 - 2	689-43311-03-4D	14 - 27
	20 - 10	6F5-14372-01	5 - 30	6G0-15754-00	8 - 9	652-24471-00	6 - 25	689-42111-01-4D	12 - 2	682-43318-01	14 - 44
6A4-13945-00	5 - 53		20 - 28	689-15755-01	8 - 14	61N-24521-00	6 - 11	69P-42112-00-4D	12 - 7	689-43373-01	15 - 2
6S6-1410E-00	5 - 18	62C-14379-00	5 - 46	61N-15758-01-4D	8 - 18	61N-24560-00	6 - 9	689-42119-00	12 - 11	689-43614-01	14 - 38
6A4-14146-00	5 - 59	6J0-14379-10	5 - 43	61N-15762-00	8 - 19	61N-24563-00	6 - 10	656-42126-01	12 - 20	648-43615-00	14 - 39
652-14147-00	5 - 52	6A4-14384-00	5 - 2	6F5-15764-00	8 - 15	62C-24566-01	6 - 13	6J0-42137-00	12 - 14	689-43616-00	14 - 33
	20 - 33		20 - 13	61T-15770-00	8 - 36	6YL-24610-01	19 - 21	689-42138-00	12 - 19	648-43617-00	14 - 36
6J0-14182-00	5 - 42		20 - 19	656-15771-00-94	8 - 29	6YK-24610-10	19 - 2	656-42153-00-94	13 - 14	689-43631-00	14 - 30
6J0-14182-20	5 - 42	6J0-14384-00	5 - 36	656-15772-00-94	8 - 31	6YL-24641-00	19 - 3	689-42154-80-94	13 - 13	689-43633-00	14 - 31
367-14195-00	5 - 26		20 - 29	61T-15774-40-94	8 - 39	62C-26311-00	12 - 23	689-42169-01	13 - 10	648-43642-00	14 - 34

NUMERICAL INDEX

PART NO.	REF. NO.	PART NO.	REF. NO.	PART NO.	REF. NO.	PART NO.	REF. NO.	PART NO.	REF. NO.	PART NO.	REF. NO.
689-43643-00	14 - 32	663-45119-00	14 - 29	664-45945-00-EL	18 - 17	90105-08M10	8 - 35	90202-06007	13 - 38	90445-11M06	7 - 2
689-43681-01	14 - 43		15 - 23	664-45947-01-EL	18 - 17	90105-10M12	18 - 4	90202-10024	13 - 35		19 - 19
689-44111-01-4D	13 - 24	61N-45127-00	17 - 25	664-45949-02-EL	18 - 17	90109-06M12	14 - 7	90202-24M32	3 - 15	90445-11M81	7 - 8
664-44113-01	13 - 25		21 - 11	664-45952-00-EL	18 - 17	90109-06M18	14 - 45	90206-05005	8 - 46		19 - 14
689-44121-01	13 - 32	69P-45127-00	16 - 17	664-45954-00-EL	18 - 17	90116-06M08	4 - 13	90206-08010	8 - 44	90461-06M01	4 - 27
689-44125-00	13 - 33	69P-45128-00	16 - 18	6L2-45987-01	18 - 12	90119-06024	16 - 19	90206-12052	11 - 11	90465-13M11	10 - 19
664-44142-00	13 - 27	69P-45159-00	16 - 20	689-45997-00	18 - 13	90119-06025	8 - 33	90206-28001	12 - 6	90467-08004	6 - 7
61N-44143-00	13 - 37	6L2-45214-00	18 - 8	69P-47467-10-5B	16 - 16	90119-06M48	18 - 7	90209-05M24	4 - 16		6 - 18
61N-44146-00	13 - 41	6L2-45215-00	18 - 9	61N-81313-09	9 - 4	90119-06M49	13 - 4	90209-47016	15 - 9		6 - 42
61N-44150-10	17 - 59	61N-45251-01	17 - 30	6E9-81328-70	9 - 7	90119-06M73	11 - 14	90240-05047	14 - 40	90467-09M03	6 - 8
664-44167-01	13 - 21	69P-45300-11-4D	17 - 1	6H3-81922-00	10 - 18	90119-06M95	10 - 8	90243-04007	14 - 4		6 - 19
61N-44176-00	17 - 18	61N-45311-02-4D	17 - 2	6AH-81994-40	4 - 28	90119-06MA0	2 - 40	90249-06M22	14 - 35		6 - 43
695-44194-00	10 - 2	61N-45315-00	17 - 26	6AH-81995-40	8 - 49	90119-06MA2	2 - 24	90250-05010	17 - 45	90480-14M14	1 - 9
69P-44311-00	17 - 9		21 - 10	61N-82317-00	10 - 6		2 - 31	90266-04M00	1 - 6	90480-15M06	11 - 2
	21 - 21	61N-45321-00	17 - 19	66T-82370-00	10 - 29	90119-06MA3	2 - 38	90266-04M01	1 - 4	90480-17M08	11 - 22
69P-44322-00	21 - 23	61N-45331-00-5B	17 - 23	61N-82519-01	10 - 10		8 - 30	90269-02M09	12 - 15	90480-25161	10 - 26
69P-44322-40	17 - 11	688-45341-10	17 - 33	682-82556-00	11 - 20		8 - 32	90280-03M03	17 - 36	90480-29045	15 - 5
	21 - 31	61N-45361-01-4D	17 - 51	6E9-82575-02	11 - 19	90119-06MA4	2 - 39		21 - 29	90501-09M08	13 - 23
61N-44323-00	21 - 26	61N-45371-00	18 - 6	689-8257Y-00	11 - 21	90119-08009	2 - 3	90280-05015	9 - 14	90501-10065	17 - 47
61N-44323-40	17 - 14	61N-45510-10	17 - 35	6E9-85516-70	9 - 9	90119-08015	2 - 25	90340-08002	17 - 28	90501-10227	8 - 38
	21 - 32	61N-45536-00	17 - 5	663-85518-00	13 - 9	90119-08M03	15 - 47	90381-12M01	15 - 20	90501-14M07	13 - 22
65W-44328-11	17 - 17	61N-45551-00	17 - 37	61N-85537-00	9 - 13	90119-08M65	2 - 4	90386-08032	12 - 18	90501-23215	12 - 17
6H4-44352-02	17 - 12	61N-45560-10	17 - 41	61N-85540-13	10 - 13	90149-05M13	12 - 13	90386-10009	13 - 15	90502-10M07	14 - 22
	21 - 24	6L2-45567-00	17 - 40	69P-85541-09	9 - 3	90151-05M05	18 - 10	90386-12069	11 - 12	90506-16M17	14 - 46
61N-44361-10	18 - 1	6L2-45567-10	17 - 40	61N-85542-00-94	10 - 5	90151-06M02	2 - 18	90386-22M67	14 - 12	90506-30M27	14 - 42
61N-44362-10	17 - 7	6L2-45567-20	17 - 40	61N-85543-09	9 - 5	90157-05M16	19 - 5	90386-38022	15 - 13	90508-14M13	13 - 34
689-44366-00	18 - 2	6L2-45567-30	17 - 40	61N-85543-19	9 - 6		19 - 23	90386-38090	15 - 11	91490-12010	13 - 30
	21 - 5	6L2-45567-40	17 - 40	61N-85550-10	9 - 1	90170-10M42	15 - 27	90386-47M22	15 - 10	91490-16010	5 - 14
6L2-44367-00	17 - 10	61N-45571-00	17 - 49	69P-85560-00	9 - 2		15 - 33	90387-06119	10 - 7		8 - 48
	21 - 7	6L2-45577-00	17 - 50	69P-85561-00	9 - 10	90171-14013	18 - 15	90387-06568	8 - 45		13 - 28
	21 - 22	6L2-45577-10	17 - 50	61N-85570-00	10 - 20	90176-10M01	15 - 38	90387-06M02	13 - 3		14 - 41
664-44514-00-94	15 - 35	6L2-45577-20	17 - 50	61N-85570-10	10 - 25	90179-06M24	1 - 8	90387-08M03	14 - 24	91490-20010	13 - 40
689-44516-00	15 - 30	6L2-45577-30	17 - 50	69T-W0001-00	20 - 1	90179-10M14	17 - 38	90387-08M25	11 - 3	91490-30022	18 - 16
69P-44518-00-94	15 - 14	61N-45587-00	17 - 4	69P-W0001-20	21 - 1	90179-16M05	9 - 15	90387-10M39	15 - 15	91490-30025	16 - 15
648-44519-00-94	15 - 16	61N-45587-10	17 - 4	689-W0004-60	4 - 2	90185-05002	18 - 11	90387-13003	12 - 3	91690-30008	14 - 21
689-44551-01-4D	15 - 43	61N-45587-20	17 - 4	61N-W0070-H0	1 - 11	90185-06062	12 - 22	90387-32002	3 - 16	91690-30016	14 - 16
689-44552-01-4D	15 - 45	61N-45587-30	17 - 4	69P-W0078-00	21 - 20	90185-22043	14 - 10	90387-33001	12 - 4	91690-40016	13 - 36
689-44553-00-94	15 - 39	61N-45587-40	17 - 4	69P-W0078-0A	21 - 30	90201-06M30	10 - 9	90430-08020	17 - 29	91690-40018	13 - 16
689-44555-00	15 - 44	61N-45587-50	17 - 4	69T-W0084-00-4D	12 - 1	90201-08M87	11 - 4		17 - 34	91690-40035	14 - 47
689-44557-00	15 - 40	61N-45587-60	17 - 4	69T-W0090-00-1S	2 - 1	90201-10M02	12 - 16		21 - 13	91690-40040	4 - 26
648-44591-A0	15 - 29	61N-45587-70	17 - 4	69T-W0093-00	20 - 18	90201-16M44	9 - 16	90445-09M55	5 - 57	92903-05600	8 - 47
	15 - 34	65W-45611-00	17 - 42	61N-W1571-11	8 - 1	90201-20417	17 - 48	90445-09M69	5 - 58	92903-06600	2 - 16
664-44591-A0	15 - 36	664-45631-02	17 - 44	656-W2810-02	6 - 44	90201-20M27	3 - 23	90445-09M75	6 - 5		4 - 7
69P-45111-10-4D	16 - 1	648-45633-00	17 - 46	90101-08339	14 - 23	90201-21567	2 - 28	90445-10M41	2 - 36		4 - 9
689-45113-A1	2 - 42	648-45635-00	17 - 43	90105-06M07	13 - 26	90201-22M03	14 - 11	90445-10M42	6 - 40		8 - 43
	20 - 14	62C-45941-00-EL	18 - 17		15 - 6	90201-28013	12 - 5	90445-10M43	6 - 6	92990-04500	6 - 24
	21 - 2	664-45941-01-EL	18 - 17	90105-06M08	15 - 26	90201-50306	2 - 41	90445-11M05	7 - 4	92990-05100	5 - 16
663-45119-00	14 - 18	664-45943-01-EL	18 - 17	90105-06M18	15 - 3	90202-06007	13 - 29		19 - 13		6 - 36

NUMERICAL INDEX

PART NO.	REF. NO.	PART NO.	REF. NO.	PART NO.	REF. NO.	PART NO.	REF. NO.	PART NO.	REF. NO.	PART NO.	REF. NO.
92990-05600	4 - 18	93210-08287	19 - 17	95380-06600	13 - 42	97880-06010	9 - 22				
	9 - 20	93210-22164	21 - 17	95380-08600	6 - 14	97880-06016	16 - 8				
	13 - 31	93210-26130	17 - 8		14 - 26	97890-04005	5 - 49				
	13 - 39		21 - 6		15 - 46	97980-04112	5 - 9				
92990-06100	10 - 12	93210-32738	6 - 12	95380-08700	11 - 7	98503-05028	6 - 35				
	10 - 17		20 - 17		11 - 9	98580-04015	5 - 12				
	10 - 24	93210-37160	15 - 12	95895-06035	17 - 31	98780-04010	6 - 23				
92990-06300	17 - 32	93210-39M89	4 - 12	97013-06016	2 - 15	99080-05600	14 - 37				
92990-08600	11 - 8		20 - 12	97013-06025	4 - 6	99530-10014	8 - 25				
	14 - 25		20 - 35	97013-06035	4 - 8						
92990-10200	15 - 28	93210-45161	17 - 13	97013-08030	8 - 10						
	15 - 37		21 - 8	97075-06020	17 - 57						
92990-14200	18 - 14		21 - 25	97075-08025	15 - 41						
92995-05600	13 - 19	93210-46M16	3 - 8	97075-08030	16 - 4						
92995-06600	2 - 11	93210-58M21	2 - 9	97090-06012	10 - 11						
	4 - 15		20 - 4		10 - 16						
	6 - 3	93210-64ME7	17 - 53		17 - 53						
	8 - 21		21 - 14	97095-05014	13 - 18						
	8 - 24	93210-65M50	17 - 56	97095-06010	8 - 40						
	8 - 27		21 - 16		10 - 3						
	10 - 4	93306-00612	17 - 52	97095-06012	6 - 15						
	10 - 15	93306-305U3	3 - 9		13 - 5						
	10 - 22	93310-62406	3 - 14	97095-06016	8 - 20						
	10 - 28	93315-22004	17 - 54	97095-06018	15 - 18						
	12 - 10	93315-220V7	17 - 6	97095-06020	6 - 2						
	15 - 19	93332-00005	17 - 39		8 - 42						
	15 - 32	93332-000W5	17 - 3		10 - 14						
	17 - 16	93390-00009	3 - 17		10 - 21						
	17 - 22	93399-99951	3 - 6		10 - 27						
	17 - 58	93440-62057	3 - 11		12 - 9						
	21 - 28	93602-20M02	3 - 21		12 - 21						
92995-08600	15 - 42	93604-10M03	17 - 24		15 - 31						
	16 - 5	93606-11M24	18 - 3	97095-06022	2 - 10						
	16 - 11	93606-12019	2 - 5	97095-06025	17 - 21						
92995-10600	18 - 5		15 - 17	97095-06035	8 - 23						
93101-16001	2 - 8		16 - 3		8 - 26						
	20 - 3	93608-12063	15 - 8	97095-06040	17 - 15						
93101-20M07	17 - 55	93700-06M03	14 - 17		21 - 27						
	21 - 15		14 - 28	97095-08020	16 - 10						
93101-22067	17 - 27		15 - 22	97585-08540	11 - 6						
	21 - 12	94702-00217	2 - 43	97595-06550	6 - 39						
93102-25008	2 - 7	95303-08700	8 - 12		12 - 8						
	20 - 2	95380-03600	6 - 31	97595-08565	15 - 48						
93102-32M07	3 - 7	95380-05600	13 - 12	97607-04112	9 - 11						
93210-06ME6	17 - 20	95380-05700	5 - 17	97607-06125	9 - 12						
	21 - 9		13 - 7	97802-04006	9 - 8						
93210-08287	7 - 7	95380-06600	4 - 14	97880-05012	9 - 19						
	19 - 10		8 - 28	97880-05030	4 - 17						